

**General Information**

■ Air Bleed Valves.....Page 2

These air bleed valves are designed to use, at the start-up of the pumps, to bleed off the air enclosed in the suction line or the other lines in the system.

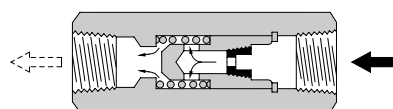
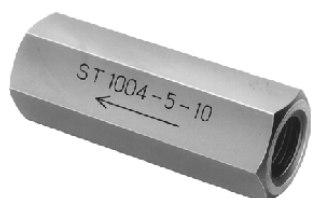

Graphic Symbol

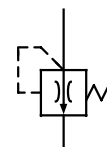

■ Pipe Flange Kits

● "F3" Series.....Page 3

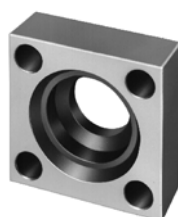

Socket Welding

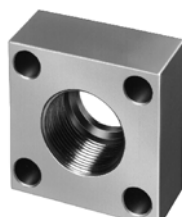

Threaded Connection

● "F5" Series.....Page 6

The dimensions of the flange mounting surface are based upon SAE 4 Bolt Split Flange (Standard Pressure Series).



Threaded Connection



Socket Welding

● "F6" Series.....Page 11

The dimensions of the flange mounting surface are based upon SAE 4 Bolt Split Flange (High Pressure Series).

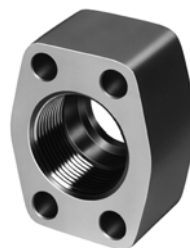

Threaded Connection



Socket Welding

Up to 25 MPa (3630 PSI)

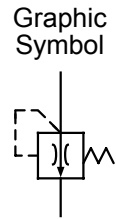
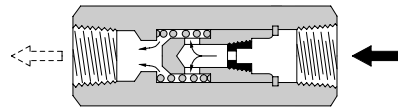
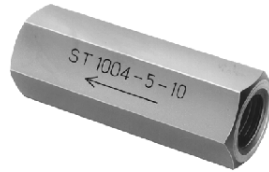

#### Specifications

Model Numbers	Max. Operating Pressure MPa (PSI)	Reseating Pressure MPa (PSI)	Cracking Pressure MPa (PSI)	Flow Rate to Reseating L/min (U.S.GPM)	Range of Usage to Pump Output Flow	Approx. Mass kg (lbs.)
ST1004-5-10*	25 (3630)	0.15 (22)	0.34 (49)	5 (1.32)	For 20 to 75 L/min (5.28 to 19.8 U.S.GPM)	0.2 (.44)
ST1004-10-10*				10 (2.64)	For Over 75 L/min (19.8 U.S.GPM)	

#### Model Number Designation

ST1004	-5	-10	*
Series Number	Flow Rate to Reseating	Design Number	Design Standards
ST1004: Air Bleed Valve	5: 5 L/min (1.32 U.S.GPM) 10: 10 L/min (2.64 U.S.GPM)	10	None: Japanese Standard "JIS" 80: European Design Standard 90: N. American Design Standard

#### Instructions

When the valve is used to bleed off the air from the pump, connect the inlet port of the valve to the discharge port of the pump as close as possible. When removing the air from the pipes, install the valve at the highest position of the system. In either case, the outlet port of the valve must be connected to the tank, the end of which is located below the oil level in the reservoir.

#### Hydraulic Fluids

##### Type of Hydraulic Fluids

- Petroleum Base Oils.....Use R & O (Rust and Oxidation inhibitor) type oils or anti-wear type oils (equivalent to ISO VG-32 or 46)
- Synthetic Fluids.....Use phosphate ester type fluid or polyol ester type fluids.
- Water Containing Fluids..Use water glycol type fluids or water in oil emulsion type fluids.
- Other Special Fluids.....Consult factory for information.

##### Recommended viscosity and Oil Temperatures

- Viscosity ranging between 15 and 400 mm<sup>2</sup>/S (77 and 1800 SSU).
- Oil temperatures between -15 and +70°C (5 and 160°F)
- Use hydraulic fluids which satisfy the recommended viscosity and oil temperatures given above.

##### Filtration Recommended...25 microns or less.

ST1004-\*-10/1080/1090

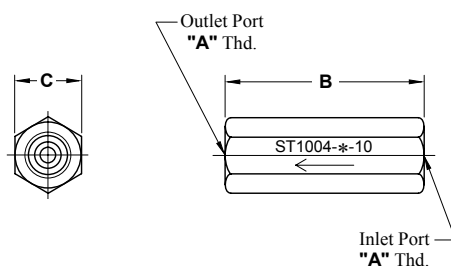

Model Numbers	"A" Thd.	mm (Inches)	
		B	C
ST1004-*-10	Rc 3/8	70 (2.76)	24 (.94)
ST1004-*-1080	3/8 BSP.F	82 (3.23)	27 (1.06)
ST1004-*-1090	3/8 NPT	70 (2.76)	24 (.94)

DIMENSIONS IN MILLIMETRES (INCHES)

Up to 25 MPa (3630 PSI)

**Specifications**

- Max. Operating Pressure...25 MPa (3630 PSI)

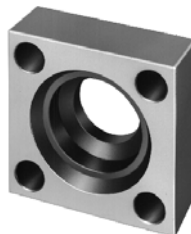

Socket  
Welding



Threaded  
Connection

**Model Number Designation**

F-	F3	-03W	-A	-N	-10	*
Material of Seal	Series Number	Flange Size	Type of Pipe Connection	O-Ring & Bolts	Design Number	Design * Standards
<b>None:</b> Standard NBR (Buna N) Seal  <b>F:</b> FPM (Viton) Seal (For Synthetic fluids)	F3	<b>03W, 03, 06V</b> <b>06W, 06, 10W</b> <b>10, 16W, 16</b> <b>24W, 24</b>	<b>A:</b> Pipe Socket Welding	<b>None:</b> With O-Ring and Mounting Bolts  <b>N:</b> No O-Ring and Mounting Bolts	11	<b>None:</b> Japanese Standard "JIS" & European Design Standard
		<b>03W, 03, 06W</b> <b>06, 10W, 10</b> <b>16W, 16, 24W</b> <b>24</b>				<b>C:</b> Block Type
		<b>03W, 03, 06V</b> <b>06W, 06, 10W</b> <b>10, 16W, 16</b> <b>24W, 24</b>	<b>B:</b> Threaded Connection	<b>None:</b> With O-Ring and Mounting Bolts  <b>N:</b> No O-Ring and Mounting Bolts	11	<b>None:</b> Japanese Standard "JIS"
		<b>03W, 03, 06W</b> <b>06, 10W, 10</b> <b>16W, 16, 24W</b> <b>24</b>				<b>80:</b> European Design Standard  <b>90:</b> N. American Design Standard

★ Three different design standards are available as shown blow. Select the suitable design standard to your requirement.

Type of Pipe Connection	Design Standard	Pipe Thread	Mounting Bolt (Socket Head Cap Screw)
Pipe Socket Welding Block Type	Japanese Standard "JIS" & European Design Standard	—	Metric Thd.
	N. American Design Standard	—	Unified Thd.
Threaded Connection	Japanese Standard "JIS"	Rc	Metric Thd.
	European Design Standard	BSP.F	Metric Thd.
	N. American Design Standard	NPT	Unified Thd.

■ Pipe Socket Welding

F3-\*-A\*-11/1190

■ Block Type

F3-\*-C\*-11/1190

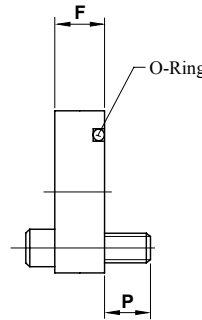
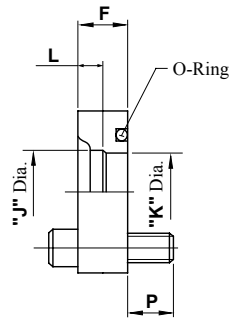
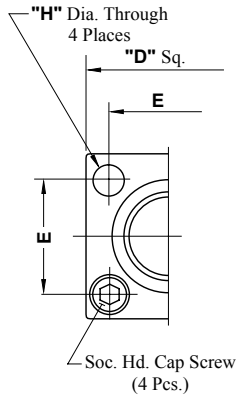

Customer's Mounting Surface

Surface should have a good machined finish.

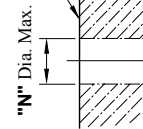

Kit Numbers	Piping Size	Dimensions mm (Inches)								O-Ring	Socket Head Cap Screw	Approx.* Mass kg (lbs.)		
		D	E	F	H	J	K	L	N				P	
F3-03W-*-11	1/4	54 (2.13)	36 (1.42)	21 (.83)	11 (.43)	14.3 (.56)	11 (.43)	8 (.31)	15 (.59)	14 (.55)	SO-NB-G25	M10 × 35 Lg.	0.5 (1.1)	
F3-03W-*-1190						17.1 (.67)	3/8-16UNC × 1-1/2 Lg.							
F3-03-*-11	3/8	54 (2.13)	36 (1.42)	21 (.83)	11 (.43)	17.8 (.70)	12.5 (.49)	9 (.35)	15 (.59)	14 (.55)	SO-NB-G25	M10 × 35 Lg.		
F3-03-*-1190						17.1 (.67)	3/8-16UNC × 1-1/2 Lg.							
F3-06V-*-11	3/8	58 (2.28)	40 (1.57)	21 (.83)	11 (.043)	17.8 (.70)	12.5 (.49)	9 (.35)	20 (.79)	14 (.55)	SO-NB-G30	M10 × 35 Lg.	0.8 (1.8)	
F3-06W-*-11	1/2					22.2 (.87)	16 (.63)	11 (.43)		14 (.55)		M10 × 35 Lg.		
F3-06W-*-1190						3/4	17.1 (.67)	3/8-16UNC × 1-1/2 Lg.						
F3-06-*-11	27.7 (1.09)						20 (.79)	12 (.47)		14 (.55)		M10 × 35 Lg.		
F3-06-*-1190	17.1 (.67)	3/8-16UNC × 1-1/2 Lg.												
F3-10W-*-11	1	76 (2.99)	56 (2.20)	27 (1.06)	13.5 (.53)	34.5 (1.36)	25 (.98)	14 (.55)	31.5 (1.24)	18 (.71)	SO-NB-G40	M12 × 45 Lg.		1.4 (3.1)
F3-10W-*-1190	1-1/4					17.5 (.69)	1/2-13UNC × 1-3/4 Lg.							
F3-10-*-11						3	43.2 (1.70)	31.5 (1.24)		16 (.63)		18 (.71)	M12 × 45 Lg.	
F3-10-*-1190	17.5 (.69)						1/2-13UNC × 1-3/4 Lg.							
F3-16W-*-11	1-1/2	100 (3.94)	73 (2.87)	35 (1.38)	17.5 (.69)	49.1 (1.93)	37.5 (1.48)	18 (.71)	50 (1.97)	25 (.98)	SO-NB-G60	M16 × 60 Lg.	2.7 (6.0)	
F3-16W-*-1190	2					22.1 (.87)	8/5-11UNC × 2-1/4 Lg.							
F3-16-*-11						3	61.1 (2.41)	47.5 (1.87)		20 (.79)		25 (.98)		M16 × 60 Lg.
F3-16-*-1190	22.1 (.87)						8/5-11UNC × 3-1/4 Lg.							
F3-24W-*-11	2-1/2	140 (5.51)	103 (4.06)	44 (1.73)	24 (.94)	77.1 (3.04)	60 (2.36)	22 (.87)	75 (2.95)	36 (1.42)	SO-NB-G85	M22 × 80 Lg.		5.8 (12.8)
F3-24W-*-1190	3					38.6 (1.52)	7/8-9UNC × 3-1/4 Lg.							
F3-24-*-11						3	90.0 (3.54)	71 (2.80)		25 (.98)		36 (1.42)	M22 × 80 Lg.	
F3-24-*-1190	38.6 (1.52)						7/8-9UNC × 3-1/4 Lg.							

\* Approx. mass is the value including socket head cap screws (4 Pcs.).

#### Threaded Connection

Japanese Standard "JIS" &  
N. American Design Standard

European Design Standard

F3-\*-B\*-11/1190

F3-\*-B\*-1180

Customer's  
Mounting  
Surface

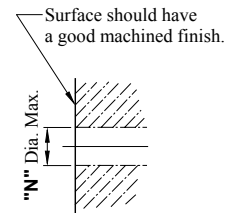
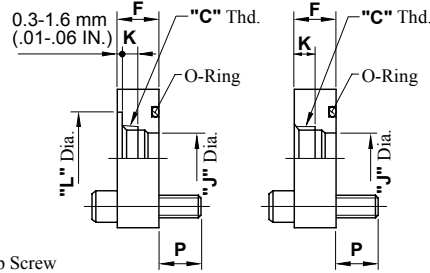
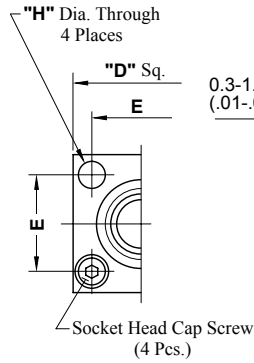
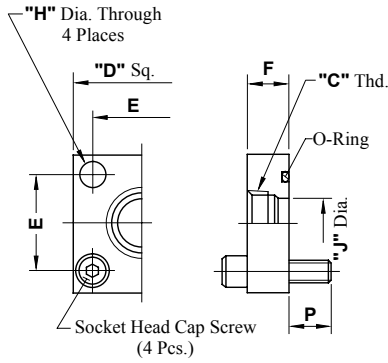

Piping Size:  
03W to 10

Piping Size:  
16W to 24

Kit Numbers	Piping Size "C" Thd.	Dimensions mm (Inches)									O-Ring	Socket Head Cap Screw	Approx.* Mass kg (lbs.)		
		D	E	F	H	J	K	L	N	P					
F3-03W-B*-11	Rc 1/4					11 (.43)	—	—							
F3-03W-B*-1180	1/4 BSP.F					11.5 (.45)	12 (.47)	21 (.83)							
F3-03W-B*-1190	1/4 NPT	54 (2.13)	36 (1.42)	21 (.83)	11 (.43)	11 (.43)	—	—			15 (.59)	17.1 (.67)	SO-NB-G25	3/8-16UNC x 1-1/2 Lg.	0.5 (1.1)
F3-03-B*-11	Rc 3/8					14 (.55)	—	—				14 (.55)		M10 x 35 Lg.	
F3-03-B*-1180	3/8 BSP.F					15 (.59)	14 (.55)	24.3 (.96)						M10 x 35 Lg.	
F3-03-B*-1190	3/8 NPT					14 (.55)	—	—				17.1 (.67)		3/8-16UNC x 1-1/2 Lg.	
F3-06W-B*-11	Rc3/8					14 (.55)	—	—				14 (.55)		M10 x 35 Lg.	
F3-06W-B*-11	Rc 1/2					17.5 (.69)	—	—				14 (.55)		M10 x 35 Lg.	
F3-06W-B*-1180	1/2 BSP.F			21 (.83)		19 (.75)	17 (.67)	29 (1.14)						M10 x 35 Lg.	0.8 (1.8)
F3-06W-B*-1190	1/2 NPT	58 (2.28)	40 (1.57)		11 (.43)	17.5 (.69)	—	—			20 (.79)	17.1 (.67)	SO-NB-G30	3/8-16UNC x 1-1/2 Lg.	
F3-06-B*-11	Rc 3/4					23 (.91)	—	—				13 (.51)		M10 x 40 Lg.	
F3-06-B*-1180	3/4 BSP.F			27 (1.06)		24.5 (.96)	20 (.79)	35.5 (1.40)						M10 x 40 Lg.	
F3-06-B*-1190	3/4 NPT					23 (.91)	—	—				17.5 (.69)		3/8-16UNC x 1-3/4 Lg.	
F3-10W-B*-11	Rc 1					29 (1.14)	—	—				18 (.71)		M12 x 45 Lg.	
F3-10W-B*-1180	1 BSP.F					30.5 (1.20)	21 (.83)	43.5 (1.71)						M12 x 45 Lg.	
F3-10W-B*-1190	1 NPT	76 (2.99)	56 (2.20)		13.5 (.53)	29 (1.14)	—	—			31.5 (1.24)	17.5 (.69)	SO-NB-G40	1/2-13UNC x 1-3/4 Lg.	1.4 (3.1)
F3-10-B*-11	Rc 1-1/4					—	—	—				15 (.59)		M12 x 50 Lg.	
F3-10-B*-1180	1-1/4 BSP.F					31.5 (1.24)	22 (.87)	53 (2.09)						M12 x 50 Lg.	
F3-10-B*-1190	1-1/4 NPT					—	—	—				15.8 (.62)		1/2-13UNC x 2 Lg.	
F3-16W-B*-11	Rc 1-1/2					43.5 (1.71)	—	—				25 (.98)		M16 x 60 Lg.	
F3-16W-B*-1180	1-1/2 BSP.F					45 (1.77)	22 (.87)	—						M16 x 60 Lg.	
F3-16W-B*-1190	1-1/2 NPT	100 (3.94)	73 (2.87)		17.5 (.69)	43.5 (1.71)	—	—			50 (1.97)	28.5 (1.12)	SO-NB-G60	5/8-11UNC x 2-1/2 Lg.	2.7 (6.0)
F3-16-B*-11	Rc 2					—	—	—				21 (.83)		M16 x 60 Lg.	
F3-16-B*-1180	2 BSP.F					47.5 (1.87)	22 (.87)	—						M16 x 60 Lg.	
F3-16-B*-1190	2 NPT					—	—	—				24.5 (.96)		5/8-11UNC x 2-1/2 Lg.	
F3-24W-B*-11	Rc 2-1/2					70 (2.76)	—	—				36 (1.42)		M22 x 80 Lg.	
F3-24W-B*-1180	2-1/2 BSP.F					72.5 (2.85)	20 (.79)	—						M22 x 80 Lg.	
F3-24W-B*-1190	2-1/2 NPT	140 (5.51)	103 (4.06)		24 (.94)	70 (2.76)	—	—			75 (2.95)	38.6 (1.52)	SO-NB-G85	7/8-9UNC x 3-1/4 Lg.	5.8 (12.8)
F3-24-B*-11	Rc 3					—	—	—				31 (1.22)		M22 x 80 Lg.	
F3-24-B*-1180	3 BSP.F					71 (2.80)	20 (.79)	—						M22 x 80 Lg.	
F3-24-B*-1190	3 NPT					—	—	—				33.6 (1.32)		7/8-9UNC x 3-1/4 Lg.	

\* Approx. Mass is the value including socket head cap screws (4 Pcs.).

**Up to 28 MPa (4060 PSI)**

**Mounting Surface : SAE J518 (Port Dimensions For Bolted Flange Connection, Standard Pressure Series)**

**■ Specifications**

**● Max. Operating Pressure:**

Maximum operating pressure varies with the type of pipe connection or flange size. Refer to the applicable installation drawings.

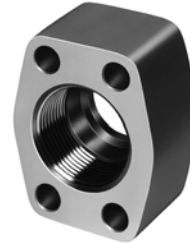

Threaded Connection

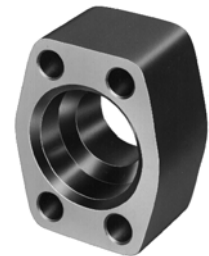

Socket Welding

**■ Model Number Designation**

<b>F-</b>	<b>F5</b>	<b>-06</b>	<b>-A</b>	<b>-10</b>	<b>*</b>	
Material of Seal	Series Number	Flange Size	Type of Pipe Connection	Design Number	Design Standards*	
<b>None:</b> Standard NBR (Buna N) Seal	<b>F5</b>	<b>04W, 04, 06X</b> <b>06, 08, 08W, 10</b> <b>12, 16, 16W, 20</b> <b>24, 28, 32</b>	<b>A: Threaded Connection</b>	<b>10</b>	<b>None:</b> Japanese Standard "JIS"	
		<b>04, 06, 08</b> <b>10, 12, 16</b> <b>20</b>			<b>80:</b> European Design Standard	
		<b>04W, 04, 06</b> <b>08, 10, 12</b> <b>16, 16W, 20</b>			<b>90:</b> N. American Design Standard	
<b>F:</b> FPM (Viton) Seal (For Synthetic Fluids)		<b>F5</b>	<b>04W, 04, 06X</b> <b>06, 08, 08W, 10</b> <b>12, 16, 16W, 20</b> <b>24, 28, 32</b>	<b>B: Socket Welding</b>	<b>10</b>	<b>None:</b> Japanese Standard "JIS" & European Design Standard
			<b>04W, 04, 06</b> <b>08, 10, 12</b> <b>16, 16W, 20, 24</b> <b>28, 32</b>			<b>90:</b> N. American Design Standard
			<b>04, 06, 08</b> <b>10, 12, 16</b> <b>20</b>	<b>C: Butt Welding</b>	<b>10</b>	<b>None:</b> Japanese Standard "JIS" & European Design Standard <b>90:</b> N. American Design Standard

★ Three different design standards are available as shown below. Select the suitable design standard to your requirement.

Type of Pipe Connection	Design Standard	Pipe Thread	Mounting Bolt (Socket Head Cap Screw)
Threaded Connection	Japanese Standard "JIS"	Rc	Metric Thd.
	European Design Standard	BSP.F	Metric Thd.
	N. American Design Standard	NPT	Unified Thd.
Pipe Socket Welding Butt Welding	Japanese Standard "JIS" & European Design Standard	—	Metric Thd.
	N. American Design Standard	—	Unified Thd.

### Installation Drawing

Japanese Standard "JIS" : F5-\*-A-10  
N. American Design Standard : F5-\*-A-1090

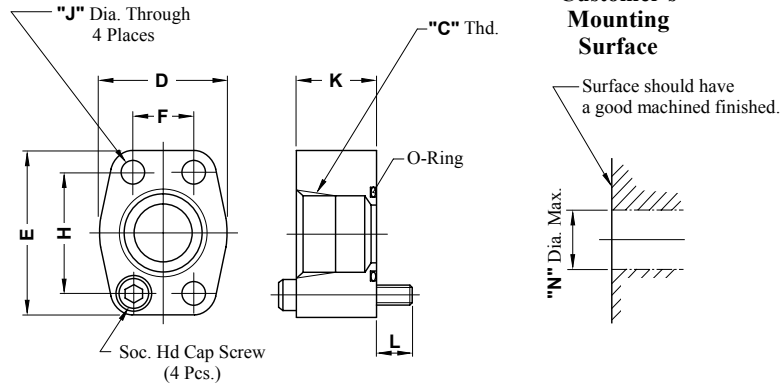

Kit Numbers	Piping Size "C" Thd.	Dimensions mm (Inches)								Socket Head Cap Screw (4 Pcs.)	O-Ring	Max. Operating Pressure MPa (PSI)	Approx. Mass kg (lbs.) <sup>*1</sup>	Recommended Tightening Torque (Tolerance ±10%) Nm (IN.lbs.) <sup>*2</sup>				
		D	E	F	H	J	K	L	N									
F5-04W-A-10	Rc 3/8	40 (1.57)	54 (2.13)	17.5 (.689)	38.1 (1.500)	8.8 (.346)	30 (1.18)	10 (.39)	13 (.51)	M8 × 40 Lg.	SO-NB-P22	28 (4060)	0.5 (1.1)	35 (310)				
F5-04-A-10	Rc 1/2							14.5 (.57)		5/16-18UNC × 1-3/4 Lg.								
F5-04W-A-1090	3/8 NPT																	
F5-04-A-1090	1/2 NPT																	
F5-06X-A-10	Rc 3/4	48 (1.89)	65 (2.56)	22.2 (.874)	47.6 (1.874)	11 (.433)	8.8 (.346)	15 (.59)	19 (.75)	M8 × 45 Lg.	SO-NB-G30	28 (4060)	0.7 (1.5)	35 (310)				
F5-06-A-10							30 (1.18)	14.5 (.57)		M10 × 45 Lg.				68.5 (606)				
F5-06-A-1090							3/4 NPT							3/8-16UNC × 1-3/4 Lg.				
F5-08W-A-10	Rc 3/4	55 (2.17)	70 (2.76)	26.2 (1.031)	52.4 (2.063)	11 (.433)	30 (1.18)	15 (.59)	26 (1.02)	M10 × 45 Lg.	SO-NB-G35	28 (4060)	0.9 (2.0)	68.5 (606)				
F5-08-A-10	Rc 1							14.5 (.57)		3/8-16UNC × 1-3/4 Lg.								
F5-08-A-1090	1 NPT																	
F5-10-A-10	Rc 1-1/4	64 (2.52)	80 (3.15)	30.2 (1.189)	58.7 (2.311)	12 (.472)	11 (.433)	17 (.67)	32 (1.26)	M10 × 55 Lg.	SO-NB-G40	28 (4060)	1.2 (2.6)	68.5 (606)				
F5-10-A-1090	1-1/4 NPT						12 (.472)	19.2 (.76)		7/16-14UNC × 2-1/4 Lg.								
F5-12-A-10	Rc 1-1/2	72 (2.83)	94 (3.70)	35.7 (1.406)	69.9 (2.752)	13.5 (.531)	38 (1.50)	17 (.67)	38 (1.50)	M12 × 55 Lg.	SO-NB-G50	21 (3050)	1.5 (3.3)	118 (1044)				
F5-12-A-1090	1-1/2 NPT							19.2 (.76)		1/2-13UNC × 2-1/4 Lg.								
F5-16W-A-10	Rc 1-1/2	85 (3.35)	102 (4.02)	42.9 (1.689)	77.8 (3.063)	13.5 (.531)	38 (1.50)	48 (1.89)	17 (.67)	63 (2.48)	SO-NB-G60	21 (3050)	1.8 (4.0)	118 (1044)				
F5-16-A-10	Rc 2							51 (2.01)							M12 × 55 Lg.	SO-NB-G65	17.5 (2540)	1.7 (3.8)
F5-16W-A-1090	1-1/2 NPT							48 (1.89)							1/2-13UNC × 2-1/4 Lg.	SO-NB-G60	21 (3050)	1.8 (4.0)
F5-16-A-1090	2 NPT							51 (2.01)								SO-NB-G65	17.5 (2540)	1.7 (3.8)
F5-20-A-10	Rc 2-1/2	102 (4.02)	114 (4.49)	50.8 (2.000)	88.9 (3.500)	13.5 (.531)	48 (1.89)	17 (.67)	63 (2.48)	M12 × 65 Lg.	SO-NB-G75	17.5 (2540)	2.0 (4.4)	118 (1044)				
F5-20-A-1090	2-1/2 NPT							21.8 (.86)		1/2-13UNC × 2-3/4 Lg.								
F5-24-A-10	Rc 3	116 (4.57)	135 (5.31)	61.9 (2.437)	106.4 (4.189)			76 (2.99)		M16 × 70 Lg.	SO-NB-G85		2.7 (6.0)	287 (2540)				
F5-28-A-10	Rc 3-1/2	134 (5.28)	153 (6.02)	69.9 (2.752)	120.7 (4.752)	17.5 (.689)	53 (2.09)	17 (.67)	88 (3.46)	M16 × 70 Lg.	SO-NB-G100	3.5 (510)	3.4 (7.5)					
F5-32-A-10	Rc 4	150 (5.91)	162 (6.38)	77.8 (3.068)	130.2 (5.126)			101 (3.98)		M16 × 70 Lg.	SO-NB-G115		3.7 (8.2)					

★ 1. Approx. mass is the value including socket head cap screws (4 Pcs.).

★ 2. The values of recommended tightening torque are for socket head cap screws and apply to when these flanges are used for pressure line.

### Installation Drawing

#### European Design Standard F5-\* -A-1180

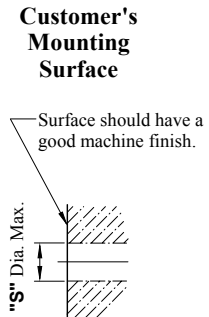
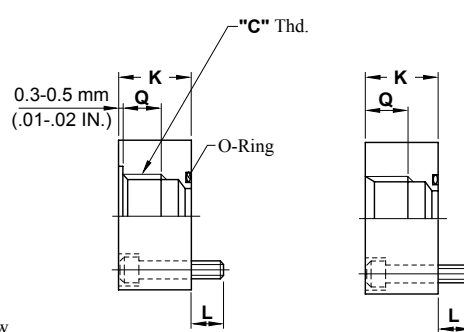
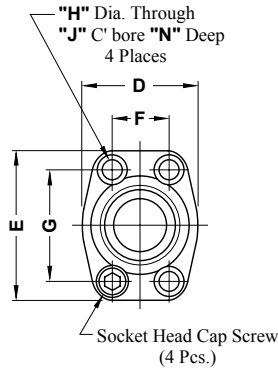

Piping Size:  
1/2 to 1-1/2

Piping Size:  
2 & 2-1/2

Kit Numbers	Piping Size "C" Thd.	Dimensions mm (Inches)											Socket Head Cap Screw (4 Pcs.)	O-Ring	Max.* Operating Pressure MPa (PSI)	Approx. Mass kg (lbs.)
		D	E	F	G	H	J	K	L	N	Q	S				
F5-04-A-1080	1/2 BSP.F	40 (1.57)	59 (2.32)	17.5 (.689)	38.1 (1.500)	8.8 (.346)	14 (.55)	31 (1.22)	12.6 (.50)	8.6 (.34)	17 (.67)	15 (.59)	M8 × 35 Lg.	SO-NB-P22	28 (4060)	0.5 (1.1)
F5-06-A-1080	3/4 BSP.F	48 (1.89)	72 (2.83)	22.2 (.874)	47.6 (1.874)	11 (.433)	17.5 (.69)	31 (1.22)	14.8 (.58)	10.8 (.43)	20 (.79)	19 (.75)	M10 × 35 Lg.	SO-NB-G30	28 (4060)	0.7 (1.5)
F5-08-A-1080	1 BSP.F	55 (2.17)	77 (3.03)	26.2 (1.031)	52.4 (2.063)	11 (.433)	17.5 (.69)	31 (1.22)	14.8 (.58)	10.8 (.43)	21 (.83)	25 (.98)	M10 × 35 Lg.	SO-NB-G35	28 (4060)	0.9 (2.0)
F5-10-A-1080	1-1/4 BSP.F	64 (2.52)	83 (3.27)	30.2 (1.189)	58.7 (2.311)	11 (.433)	17.5 (.69)	39 (1.54)	16.8 (.66)	10.8 (.43)	22 (.87)	32 (1.26)	M10 × 45 Lg.	SO-NB-G40	28 (4060)	1.2 (2.6)
F5-12-A-1080	1-1/2 BSP.F	72 (2.83)	99 (3.90)	35.7 (1.406)	69.9 (2.752)	13.5 (.531)	21 (.83)	41 (1.61)	17.5 (.69)	13.5 (.53)	22 (.87)	38 (1.50)	M12 × 45 Lg.	SO-NB-G50	21 (3050)	1.6 (3.5)
F5-16-A-1080	2 BSP.F	85 (3.35)	107 (4.21)	42.9 (1.689)	77.8 (3.063)	13.5 (.531)	21 (.83)	41 (1.61)	17.5 (.69)	13.5 (.53)	31 (1.22)	50 (1.97)	M12 × 45 Lg.	SO-NB-G65	17.5 (2540)	1.8 (4.0)
F5-20-A-1080	2-1/2 BSP.F	102 (4.02)	118 (4.65)	50.8 (2.000)	88.9 (3.500)	13.5 (.531)	21 (.83)	46 (1.81)	17.5 (.69)	13.5 (.53)	31 (1.22)	63 (2.48)	M12 × 50 Lg.	SO-NB-G75	17.5 (2540)	1.9 (4.2)

\* Approx. mass is the value including socket head cap screws (4 Pcs.).

#### ● Recommended Tightening Torque For Socket Head Cap Screw

Kit Numbers	Tightening Torque	
	Recommendation Nm (IN.lbs.)	Tolerance
F5-04-A-1080	35 (310)	±10%
F5-06-A-1080	68.5 (606)	
F5-08-A-1080		
F5-10-A-1080		
F5-12-A-1080	118 (1044)	
F5-16-A-1080		
F5-20-A-1080		

Note: The values of tightening torque above apply to when these flanges are used for pressure line.

Japanese Standard "JIS" &  
European Design Standard : F5-\*-B-10  
N. American Design Standard : F5-\*-B-1090

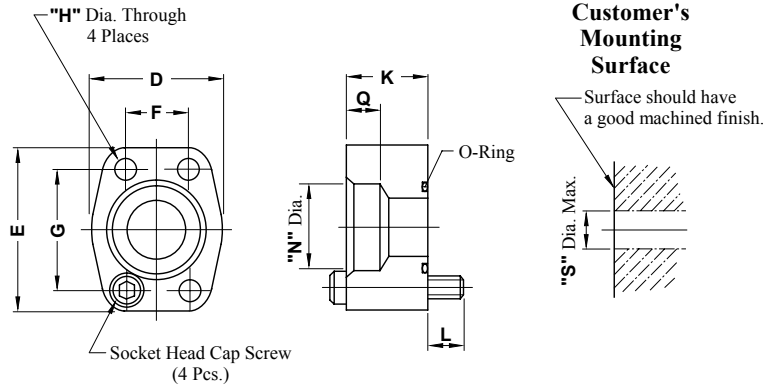

#### Recommended Tightning Torque For Socket Head Cap Screw

Kit Numbers	Tightening Torque	
	Recommendation Nm (IN.lbs.)	Tolerance
F5-04W-B F5-04-B F5-06X-B	35 (310)	±10%
F5-06-B F5-08W-B F5-08-B F5-10-B	68.5 (660)	
F5-12-B F5-16W-B F5-16-B F5-20-B	118 (1044)	
F5-24-B F5-28-B F5-32-B	287 (2540)	

Note: The values of tightening torque above apply to when these flanges are used for pressure line.

Kit Numbers	Piping Size	Dimensions mm (Inches)										Socket Head Cap Screw (4 Pcs.)	O-Ring	Max. Operating Pressure MPa (PSI)	Approx.* Mass kg (lbs.)	
		D	E	F	G	H	K	L	N	Q	S					
F5-04W-B-10	3/8							10 (.39)	17.8 (.701)	9 (.35)		13 (.51)	M8 × 40 Lg.	SO-NB-P22	28 (4060)	0.5 (1.1)
F5-04W-B-1090		40 (1.57)	54 (2.13)	17.5 (.689)	38.1 (1.500)	8.8 (.346)	30 (1.18)	14.5 (.57)					5/16-18UNC × 1-3/4 Lg.			
F5-04-B-10	1/2						10 (.39)	22.2 (.874)	11 (.43)			M8 × 40 Lg.				
F5-04-B-1090		40 (1.57)	54 (2.13)	17.5 (.689)	38.1 (1.500)	8.8 (.346)	30 (1.18)	14.5 (.57)				5/16-18UNC × 1-3/4 Lg.				
F5-06X-B-10	3/4					8.8 (.346)		15 (.59)	27.7 (1.091)	12 (.47)	19 (.75)		M8 × 45 Lg.	SO-NB-G30	28 (4060)	0.7 (1.5)
F5-06-B-10		48 (1.89)	65 (2.56)	22.2 (.874)	47.6 (1.874)	11 (.433)	30 (1.18)	14.5 (.57)				M10 × 45 Lg.	14 (2030)			
F5-06-B-1090		48 (1.89)	65 (2.56)	22.2 (.874)	47.6 (1.874)	11 (.433)	30 (1.18)	14.5 (.57)				3/8-16UNC × 1-3/4 Lg.				
F5-08W-B-10	3/4							15 (.59)	27.7 (1.091)	12 (.47)	26 (1.02)		M10 × 45 Lg.	SO-NB-G35	28 (4060)	0.9 (2.0)
F5-08-B-10	1	55 (2.17)	70 (2.76)	26.2 (1.031)	52.4 (2.063)	11 (.433)	30 (1.18)	14.5 (.57)	34.5 (1.358)	14 (.55)					14 (2030)	
F5-08-B-1090		55 (2.17)	70 (2.76)	26.2 (1.031)	52.4 (2.063)	11 (.433)	30 (1.18)	14.5 (.57)	34.5 (1.358)	14 (.55)			3/8-16UNC × 1-3/4 Lg.			
F5-10-B-10	1-1/4					11 (.433)		17 (.67)	43.2 (1.701)	16 (.63)	32 (1.26)		M10 × 55 Lg.	SO-NB-G40	14 (2030)	1.2 (2.7)
F5-10-B-1090		64 (2.52)	80 (3.15)	30.2 (1.189)	58.7 (2.311)	12 (.472)	38 (1.50)	19.2 (.76)					7/16-14UNC × 2-1/4 Lg.			
F5-12-B-10	1-1/2							17 (.67)	49.1 (1.933)	18 (.71)	38 (1.50)		M12 × 55 Lg.	SO-NB-G50	14 (2030)	1.5 (3.3)
F5-12-B-1090		72 (2.83)	94 (3.70)	35.7 (1.406)	69.9 (2.752)	13.5 (.531)	38 (1.50)	19.2 (.76)					1/2-13UNC × 2-1/4 Lg.			
F5-16W-B-10	1-1/2							17 (.67)	49.1 (1.933)	18 (.71)	48 (1.89)		M12 × 55 Lg.	SO-NB-G60	21 (3050)	1.8 (3.7)
F5-16W-B-1090		85 (3.35)	102 (4.02)	42.9 (1.689)	77.8 (3.063)	13.5 (.531)	38 (1.50)	19.2 (.76)					1/2-13UNC × 2-1/4 Lg.			
F5-16-B-10	2							17 (.67)	61.1 (2.406)	20 (.79)	51 (2.01)		M12 × 55 Lg.	SO-NB-G65	10.5 (1520)	1.7 (3.8)
F5-16-B-1090		85 (3.35)	102 (4.02)	42.9 (1.689)	77.8 (3.063)	13.5 (.531)	38 (1.50)	19.2 (.76)					1/2-13UNC × 2-1/4 Lg.			
F5-20-B-10	2-1/2							17 (.67)	77.1 (3.035)	22 (.87)	63 (2.48)		M12 × 65 Lg.	SO-NB-G75	7 (1020)	2.0 (4.4)
F5-20-B-1090		102 (4.02)	114 (4.49)	50.8 (2.000)	88.9 (3.500)	13.5 (.531)	48 (1.89)	21.8 (.86)					1/2-13UNC × 2-3/4 Lg.			
F5-24-B-10	3							17 (.67)	90.0 (3.543)	25 (.98)	76 (2.99)		M16 × 55 Lg.	SO-NB-G85	3.5 (510)	2.7 (6.0)
F5-24-B-1090		116 (4.57)	135 (5.31)	61.9 (2.437)	106.4 (4.189)	17.5 (.689)	38 (1.50)	19.2 (.76)					5/8-11UNC × 2-1/4 Lg.			
F5-28-B-10	3-1/2							17 (.67)	102.8 (4.047)	28 (1.10)	88 (3.46)		M16 × 55 Lg.	SO-NB-G100	3.5 (510)	3.4 (7.5)
F5-28-B-1090		134 (5.28)	153 (6.02)	69.9 (2.752)	120.7 (4.752)	17.5 (.689)	38 (1.50)	19.2 (.76)					5/8-11UNC × 2-1/4 Lg.			
F5-32-B-10	4							17 (.67)	115.5 (4.547)	31.5 (1.24)	101 (3.98)		M16 × 55 Lg.	SO-NB-G115	3.5 (510)	3.7 (8.2)
F5-32-B-1090		150 (5.91)	162 (6.38)	77.8 (2.063)	130.2 (5.126)	17.5 (.689)	38 (1.50)	19.2 (.76)					5/8-11UNC × 2-1/4 Lg.			

\* Approx. mass is the value including socket head cap screws (4 Pcs.).

Japanese Standard "JIS" & European Design Standard : F5-\*-C-10  
N. American Design Standard : F5-\*-C-1090

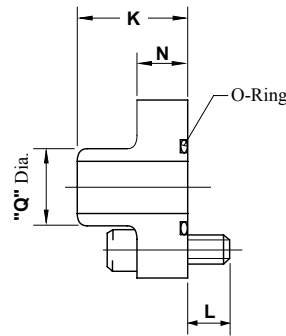
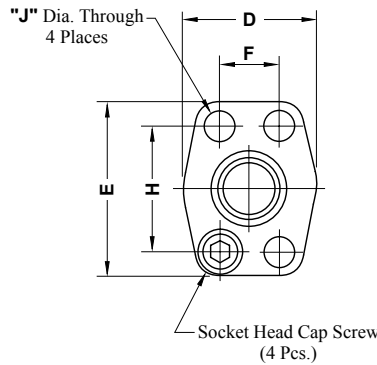

**Customer's  
Mounting  
Surface**

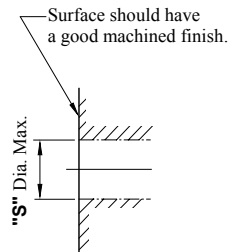

Kit Numbers	Piping Size	Dimensions mm (Inches)										Socket Head Cap Screw (4 Pcs.)	O-Ring	Max. Operating Pressure MPa (PSI)	Approx.* Mass kg (lbs.)
		D	E	F	H	J	K	L	N	Q	S				
F5-04-C-10	1/2	40	54	17.5	38.1	8.8	39	13	17	21.7	13	M8 × 30 Lg.	SO-NB-P22	28 (4060)	0.25 (.6)
F5-04-C-1090		(1.57)	(2.13)	(.689)	(1.500)	(.346)	(1.54)	(.51)	(.67)	(.85)	(.51)	5/16-18UNC × 1-1/4 Lg.			
F5-06-C-10	3/4	48	65	22.2	47.6	11	41	16	19	27.2	19	M10 × 35 Lg.	SO-NB-G30	28 (4060)	0.35 (.8)
F5-06-C-1090		(1.89)	(2.56)	(.874)	(1.874)	(.433)	(1.61)	(.63)	(.75)	(1.07)	(.75)	3/8-16UNC × 1-1/2 Lg.			
F5-08-C-10	1	55	70	26.2	52.4	11	42	16	19	34	26	M10 × 35 Lg.	SO-NB-G35	28 (4060)	0.45 (1.0)
F5-08-C-1090		(2.17)	(2.76)	(1.031)	(2.063)	(.433)	(1.65)	(.63)	(.75)	(1.34)	(1.02)	3/8-16UNC × 1-1/2 Lg.			
F5-10-C-10	1-1/4	64	80	30.2	58.7	11	44	16	19	42.7	32	M10 × 35 Lg.	SO-NB-G40	28 (4060)	0.63 (1.4)
F5-10-C-1090		(2.52)	(3.15)	(1.189)	(2.311)	(.433)	(1.73)	(.63)	(.75)	(1.68)	(1.26)	7/16-14UNC × 1-1/2 Lg.			
F5-12-C-10	1-1/2	72	94	35.7	69.9	13.5	50	18	22	48.6	38	M12 × 40 Lg.	SO-NB-G50	21 (3050)	1.3 (2.9)
F5-12-C-1090		(2.83)	(3.70)	(1.406)	(2.752)	(.531)	(1.97)	(.71)	(.87)	(1.91)	(1.50)	1/2-13UNC × 1-1/2 Lg.			
F5-16-C-10	2	85	102	42.9	77.8	13.5	50	18	22	60.5	51	M12 × 40 Lg.	SO-NB-G65	17.5 (2540)	1.3 (2.9)
F5-16-C-1090		(3.35)	(4.02)	(1.689)	(3.063)	(.531)	(1.97)	(.71)	(.87)	(2.38)	(2.01)	1/2-13UNC × 1-1/2 Lg.			
F5-20-C-10	2-1/2	102	114	50.8	88.9	13.5	50	20	25	76.3	63	M12 × 45 Lg.	SO-NB-G75	14 (2030)	1.4 (3.1)
F5-20-C-1090		(4.02)	(4.49)	(2.000)	(3.500)	(.531)	(1.97)	(.79)	(.98)	(3.00)	(2.48)	1/2-13UNC × 1-3/4 Lg.			

★ Approx. mass is the value including socket head cap screws (4 Pcs.).

#### ● Recommended Tightening Torque For Socket Head Cap Screw

Kit Numbers	Tightening Torque	
	Recommendation Nm (IN.lbs.)	Tolerance
F5-04-C	35 (310)	±10%
F5-06-C	68.5 (660)	
F5-08-C		
F5-10-C		
F5-12-C	118 (1044)	
F5-16-C		
F5-20-C		

Note: The values of tightening torque above apply to when these flanges are used for pressure line.

Up to 42 MPa (6090 PSI)

**Mounting Surface : SAE J518 (Port Dimensions For Bolted Flange Connection, High Pressure Series)**

**Specifications**

Model Numbers	Max. Operating Pressure MPa (PSI)	Remarks
F6-*-A-*-10/1080/1090	31 (4500)	Threaded Connection
F6-*-B-*-10/1090	42 (6090)	Pipe Socket Welding

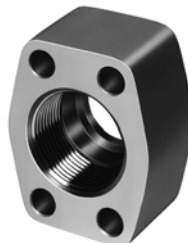

Threaded Connection



Socket Welding

**Model Number Designation**

F-	F6	-06	-A	-M	-10	*
Material of Seal	Series Number	Flange Size	Type of Pipe Connection	Type of Mounting Bolt	Design Number	Design * Standards
<b>None:</b> Standard NBR (Buna N) Seal	<b>F6</b>	<b>04W, 04</b> <b>06W, 06</b> <b>08W, 08</b> <b>10W, 10</b> <b>12W, 12</b>	<b>A:</b> Threaded Connection	<b>M:</b> Metric Thd.	<b>10</b>	<b>None:</b> Japanese Standard "JIS"
		<b>04W, 04</b> <b>06W, 06</b> <b>08W, 08</b> <b>10W, 10</b> <b>12W, 12</b>		<b>M:</b> Metric Thd.		<b>80:</b> European Design Standard
		<b>04W, 04</b> <b>06W, 06</b> <b>08W, 08</b> <b>10W, 10</b> <b>12W, 12</b>		<b>U:</b> Unified Thd.		<b>90:</b> N. American Design Standard
<b>F:</b> FPM (Viton) Seal (For Synthetic Fluids)		<b>04W, 04</b> <b>06W, 06</b> <b>08W, 08</b> <b>10W, 10</b> <b>12W, 12</b>	<b>B:</b> Pipe Socket Welding	<b>M:</b> Metric Thd.	<b>10</b>	<b>None:</b> Japanese Standard "JIS" & European Design Standard
		<b>04W, 04</b> <b>06W, 06</b> <b>08W, 08</b> <b>10W, 10</b> <b>12W, 12</b>		<b>U:</b> Unified Thd.		<b>90:</b> N. American Design Standard

★ Three different design standards are available as shown below. Select the suitable design standard to your requirement.

Type of Pipe Connection	Design Standard	Pipe Thread	Mounting Bolt (Socket Head Cap Screw)
Threaded Connection	Japanese Standard "JIS"	Re	Metric Thd.
	European Design Standard	BSP.F	Metric Thd.
	N. American Design Standard	NPT	Unified Thd.
Pipe Socket Welding	Japanese Standard "JIS" & European Design Standard	—	Metric Thd.
	N. American Design Standard	—	Unified Thd.

#### Installation Drawing

Japanese Standard "JIS" : F6-\*-A-M-10  
N. American Design Standard : F6-\*-A-U-1090

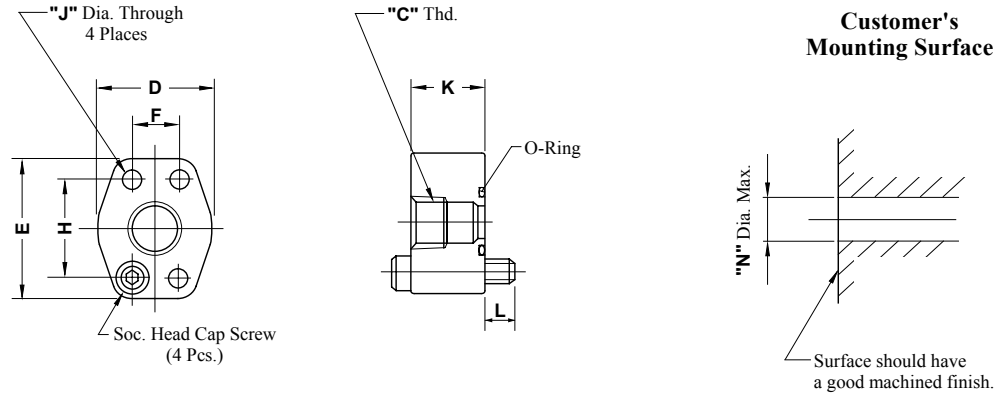

Model Numbers	Piping Size "C" Thd.	Dimensions mm (Inches)								Socket Head Cap Screw (4 Pcs.)	O-Ring	Approx. Mass <sup>*1</sup> kg (lbs.)	Recommended Tightening Torque (Tolerance ±10%) Nm (IN.lbs.) <sup>*2</sup>
		D	E	F	H	J	K	L	N				
F6-04W-A-M-10	Rc 3/8	48 (1.89)	56.5 (2.22)	18.2 (.717)	40.5 (1.594)	8.8 (.346)	28 (1.10)	12 (.47)	15 (.59)	M8 × 40 Lg.	SO-NB-P22	0.4 (.9)	35 (310)
F6-04-A-M-10	Rc 1/2						26 (1.02)	12.1 (.48)		5/16-18UNC × 1-1/2 Lg.			
F6-04W-A-U-1090	3/8 NPT												
F6-04-A-U-1090	1/2 NPT												
F6-06W-A-M-10	Rc 1/2	57.5 (2.26)	77.5 (3.05)	23.8 (.937)	50.8 (2.000)	11 (.433)	30	15 (.59)	21 (.83)	M10 × 45 Lg.	SO-NB-G30	0.9 (2.0)	68.5 (606)
F6-06-A-M-10	Rc 3/4						14.5 (.57)	3/8-16UNC × 1-3/4 Lg.					
F6-06W-A-U-1090	1/2 NPT												
F6-06-A-U-1090	3/4 NPT												
F6-08W-A-M-10	Rc 3/4	65 (2.56)	81 (3.19)	27.8 (1.094)	57.2 (2.252)	13.5 (.531)	30 (1.18)	15 (.59)	26 (1.02)	M12 × 45 Lg.	SO-NB-G35	1.1 (2.4)	118 (1044)
F6-08-A-M-10	Rc 1						26.5 (1.04)	18 (.71)		1/2-13UNC × 1-3/4 Lg.			
F6-08W-A-U-1090	3/4 NPT												
F6-08-A-U-1090	1 NPT												
F6-10W-A-M-10	Rc 1	72 (2.83)	95 (3.74)	31.8 (1.252)	66.7 (2.626)	13.5 (.531)	34 (1.34)	16 (.63)	34 (1.34)	M12 × 50 Lg.	SO-NB-G40	1.3 (2.9)	118 (1044)
F6-10-A-M-10	Rc 1-1/4						34 (1.34)	16.8 (.66)		1/2-13UNC × 2 Lg.			
F6-10W-A-U-1090	1 NPT												
F6-10-A-U-1090	1-1/4 NPT												
F6-12W-A-M-10	Rc 1-1/4	90 (3.54)	113 (4.45)	36.5 (1.437)	79.4 (3.126)	17.5 (.689)	34 (1.34)	21 (.83)	44 (1.73)	M16 × 55 Lg.	SO-NB-G50	1.5 (3.3)	287 (2540)
F6-12-A-M-10	Rc 1-1/2						34 (1.34)	23.2 (.91)		5/8-11UNC × 2-1/4 Lg.			
F6-12W-A-U-1090	1-1/4 NPT												
F6-12-A-U-1090	1-1/2 NPT												

★1. Approx. mass is the value including socket head cap screws (4 Pcs.).

★2. The values of recommended tightening torque are for socket head cap screws.

European Design Standard : F6-\*-A-M-1080

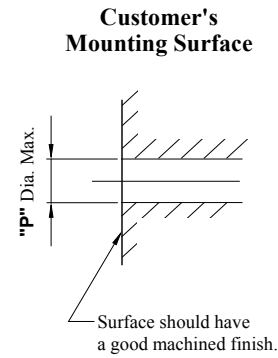
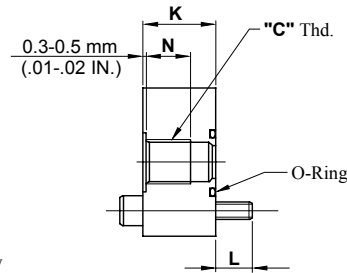
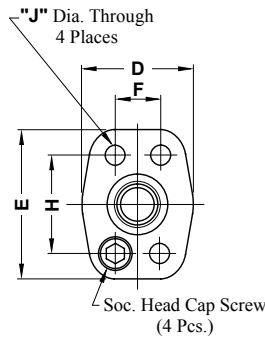

Model Numbers	Piping Size "C" Thd.	Dimensions mm (Inches)									Socket Head Cap Screw (4 Pcs.)	O-Ring	Approx. Mass kg (lbs.) <sup>*1</sup>	Recommended Tightening Torque (Tolerance ±10%) Nm (IN.lbs.) <sup>*2</sup>
		D	E	F	H	J	K	L	N	P				
F6-04W-A-M-1080	3/8 BSP.F	48 (1.89)	56.5 (2.22)	18.2 (.717)	40.5 (1.594)	8.8 (.346)	28 (1.10)	12 (.47)	14 (.55)	15 (.59)	M8 × 40 Lg.	SO-NB-P22	0.4 (.9)	35 (310)
F6-04-A-M-1080	1/2 BSP.F							17 (.67)						
F6-06W-A-M-1080	1/2 BSP.F	57.5 (2.26)	77.5 (3.05)	23.8 (.937)	50.8 (2.000)	11 (.433)	30 (1.18)	15 (.59)	17 (.67)	21 (.83)	M10 × 45 Lg.	SO-NB-G30	0.9 (2.0)	68.5 (606)
F6-06-A-M-1080	3/4 BSP.F							20 (.79)						
F6-08W-A-M-1080	3/4 BSP.F	65 (2.56)	81 (3.19)	27.8 (1.094)	57.2 (2.252)	13.5 (.531)	30 (1.18)	15 (.59)	20 (.79)	26 (1.02)	M12 × 45 Lg. M12 × 50 Lg.	SO-NB-G35	1.1 (2.4)	118 (1044)
F6-08-A-M-1080	1 BSP.F						34 (1.34)	16 (.63)	21 (.83)					
F6-10W-A-M-1080	1 BSP.F	72 (2.83)	95 (3.74)	31.8 (1.252)	66.7 (2.626)	13.5 (.531)	34 (1.34)	16 (.63)	21 (.83)	34 (1.34)	M12 × 50 Lg. M12 × 55 Lg.	SO-NB-G40	1.3 (2.9)	118 (1044)
F6-10-A-M-1080	1-1/4 BSP.F						39 (1.54)	22 (.87)						
F6-12W-A-M-1080	1-1/4 BSP.F	90 (3.54)	113 (4.45)	36.5 (1.437)	79.4 (3.126)	17.5 (.689)	34 (1.34)	21 (.83)	22 (.87)	44 (1.73)	M16 × 55 Lg. M16 × 60 Lg.	SO-NB-G50	1.5 (3.3)	287 (2540)
F6-12-A-M-1080	1-1/2 BSP.F						39 (1.54)							

★1. Approx. mass is the value including socket head cap screws (4 Pcs.).

★2. The values of recommended tightening torque are for socket head cap screw.



Japanese Standard "JIS" &

European Design Standard : F6-\*-B-M-10

N. American Design Standard : F6-\*-B-U-1090

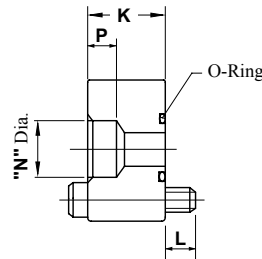
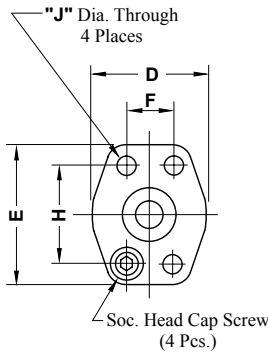

**Customer's  
Mounting Surface**

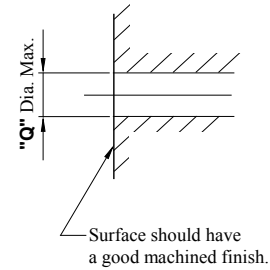

Model Numbers	Piping Size	Dimensions mm (Inches)										Socket Head Cap Screw (4 Pcs.)	O-Ring	Approx. Mass kg (lbs.) <sup>*1</sup>	Recommended Tightening Torque (Tolerance ±10%) Nm (IN.lbs.) <sup>*2</sup>
		D	E	F	H	J	K	L	N	P	Q				
F6-04W-B-M-10	3/8						28 (1.10)	12 (.47)	17.8 (.701)	9 (.35)		M8 × 40 Lg.	SO-NB-P22	0.4 (.9)	35 (310)
F6-04W-B-U-1090		48 (1.89)	56.5 (2.22)	18.2 (.717)	40.5 (1.594)	8.8 (.346)	26 (1.02)	12 (.48)			15 (.59)	5/16-18UNC × 1-1/2 Lg.			
F6-04-B-M-10	1/2						28 (1.10)	12 (.47)	22.2 (.874)	11 (.43)		M8 × 40 Lg.	SO-NB-P22	0.4 (.9)	35 (310)
F6-04-B-U-1090							26 (1.02)	12 (.48)			15 (.59)	5/16-18UNC × 1-1/2 Lg.			
F6-06W-B-M-10	1/2							15 (.59)	22.2 (.874)	11 (.43)		M10 × 45 Lg.	SO-NB-G30	0.9 (2.0)	68.5 (606)
F6-06W-B-U-1090		57.5 (2.26)	77.5 (3.05)	23.8 (.937)	50.8 (2.000)	11 (.433)	30 (1.18)	14.5 (.57)			21 (.83)	3/8-16UNC × 1-3/4 Lg.			
F6-06-B-M-10	3/4						15 (.59)	27.7 (1.091)	12 (.47)			M10 × 45 Lg.	SO-NB-G30	0.9 (2.0)	68.5 (606)
F6-06-B-U-1090							14.5 (.57)				21 (.83)	3/8-16UNC × 1-3/4 Lg.			
F6-08W-B-M-10	3/4						30 (1.18)	15 (.59)	27.7 (1.091)	12 (.47)		M12 × 45 Lg.	SO-NB-G35	1.1 (2.4)	118 (1044)
F6-08W-B-U-1090		65 (2.56)	81 (3.19)	27.8 (1.094)	57.2 (2.252)	13.5 (.531)	26.5 (1.04)	18 (.71)			26 (1.02)	1/2-13UNC × 1-3/4 Lg.			
F6-08-B-M-10	1						30 (1.18)	15 (.59)	34.5 (1.358)	14 (.55)		M12 × 45 Lg.	SO-NB-G35	1.1 (2.4)	118 (1044)
F6-08-B-U-1090							26.5 (1.04)	18 (.71)			26 (1.02)	1/2-13UNC × 1-3/4 Lg.			
F6-10W-B-M-10	1						16 (.63)	34.5 (1.358)	14 (.55)			M12 × 50 Lg.	SO-NB-G40	1.3 (2.9)	118 (1044)
F6-10W-B-U-1090		72 (2.83)	95 (3.74)	31.8 (1.252)	66.7 (2.626)	13.5 (.531)	34 (1.34)	16.8 (.66)			34 (1.34)	1/2-13UNC × 2 Lg.			
F6-10-B-M-10	1-1/4						16 (.63)	43.2 (1.701)	16 (.63)			M12 × 50 Lg.	SO-NB-G40	1.3 (2.9)	118 (1044)
F6-10-B-U-1090							16.8 (.66)				34 (1.34)	1/2-13UNC × 2 Lg.			
F6-12W-B-M-10	1-1/4						21 (.83)	43.2 (1.701)	16 (.63)			M16 × 55 Lg.	SO-NB-G50	1.5 (3.3)	287 (2540)
F6-12W-B-U-1090		90 (3.54)	113 (4.45)	36.5 (1.437)	79.4 (3.126)	17.5 (.689)	34 (1.34)	23.2 (.91)			44 (1.73)	5/8-11UNC × 2-1/4 Lg.			
F6-12-B-M-10	1-1/2						21 (.83)	49.1 (1.933)	18 (.71)			M16 × 55 Lg.	SO-NB-G50	1.5 (3.3)	287 (2540)
F6-12-B-U-1090							23.2 (.91)				44 (1.73)	5/8-11UNC × 2-1/4 Lg.			

★1. Approx. mass is the value including socket head cap screws (4 Pcs.).

★2. The values of recommended tightening torque are for socket head cap screws.