



**E SERIES
PROPORTIONAL DIRECTIONAL AND
FLOW CONTROL VALVES**
EDFHG-03/04/06 (3/8,1/2,3/4) Sub-plate Mounting

**PROPORTIONAL
CONTROLS**

General Information

Up to 24.5 MPa (3550 PSI), 280 L/min (74.0 U.S.GPM)

These valves are double-deck directional and flow control valves employing as their pilot the electro-hydraulic proportional pressure reducing valves with two proportional solenoids. The flow rate can be controlled by changing an input current to the solenoids and the direction of the flow can be controlled by providing the current to either solenoid of the two.

By combining the valves with the power amplifiers specially designed for the valves, the speed control, acceleration, deceleration and directional control can be done with a single valve, which eventually makes the hydraulic circuits simple and contributes the cost of the hydraulic systems.

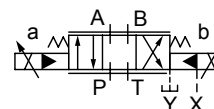
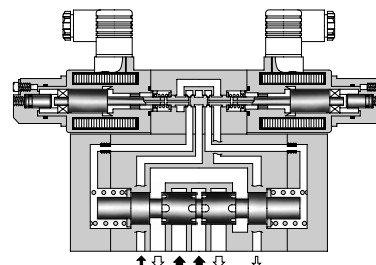

Hydraulic Fluids

Fluid Types

Any type of hydraulic fluid listed in the table below can be used.

Petroleum base oils	Use fluids equivalent to ISO VG 32 or VG 46.
Synthetic Fluids	Use phosphate ester or polyol ester fluid. When phosphate ester fluid is used, prefix "F-" to the model number because the special seals (fluororubber) are required to be used.
Water Containing Fluids	Use water-glycol fluid.

Note: For use with hydraulic fluids other than those listed above, please consult your Yuken representatives in advance.

Recommended Fluid Viscosity and Temperature

Use hydraulic fluids which satisfy the both recommended viscosity and oil temperatures given in the table below.

Viscosity	Temperature
20 - 400 mm ² /s (98 - 1800 SSU)	0 - +60°C (32 - 140°F)

Control of Contamination

Due caution must be paid to maintaining control over contamination of the hydraulic fluids which may otherwise lead to breakdowns and shorten the life of the valve. Please maintain the degree of contamination within NAS 1638-Grade 11. Use 20 μm or finer line filter.



Specifications / Model Number Designation

■ Specifications

Model No.		EDFHG-03	EDFHG-04	EDFHG-06
Description				
Max. Operating Pressure MPa (PSI)		24.5 (3550)		
Rated Flow L/min (U.S.GPM) at Valve Pressure Difference: 1.0 MPa (145 PSI)		100 (26.4)	140 (37.0)	280 (74.0)
Pilot Pressure ^{★1} MPa (PSI)		1.5 - 16 (220 - 2320) ^{★1}		
Pilot Flow L/min (U.S.GPM)	at Normal	1 (.26)	1 (.26)	1 (.26)
	at Transition	3 (.79)	4 (1.06)	6 (1.59)
Max. Tank Line Back Pressure MPa (PSI)		16 (2320)	21 (3050)	21 (3050)
Max. Drain Line Back Pressure MPa (PSI)		3.0 (435) ^{★2}		
Rated Current		800 mA	980 mA	900 mA
Coil Resistance		10 Ω		
Hysteresis		Less than 5% ^{★3}		
Repeatability		Less than 1% ^{★3}		
Approx. Mass kg (lbs.)		11 (24.3)	12 (26.5)	15 (33.1)

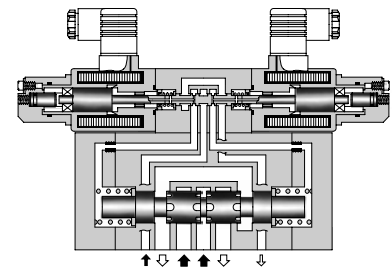
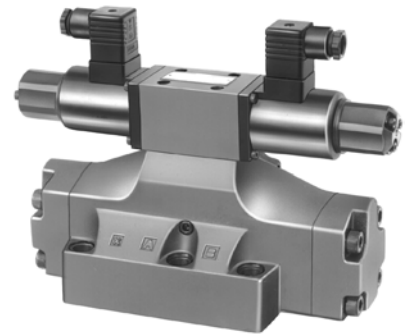

- ★ 1. Take care to keep the difference between the pilot pressure and drain port back pressure consistently greater than 1.5 MPa (220 PSI).
- ★ 2. To obtain stable performance, keep the drain port back pressure low and minimize its fluctuations.
- ★ 3. The hysteresis and repeatability values indicated in the specifications for each control valve are determined under the following conditions:
 - Hysteresis Value: Obtained when Yuken's applicable power amplifier is used.
 - Repeatability Value: Obtained when Yuken's applicable power amplifier is used under the same conditions.

■ Model Number Designation

F-	EDFHG	-03	-100	-3C2	-XY	-E	-31	*
Special Seals	Series Number	Valve Size	Rated Flow L/min (U.S.GPM)	Spool Type ^{★1}	Direction of Flow	Pilot Connection	Design Number	Design Standards
F: Special Seals for Phosphate Ester Type Fluids (Omit if not required)	EDFHG: Proportional Electro-Hydraulic Directional & Flow Control Valves (Sub-Plate Mtg.)	03	100 : 100 (26.4)	<div style="display: flex; justify-content: space-around;"> <div style="text-align: center;">3C2 </div> <div style="text-align: center;">3C40 </div> </div>	XY: Metre-in • Metre-out	E: External Pilot None: Internal Pilot	31	Refer to ★ 2
		04	140 : 140 (37.0)				31	
		06	280 : 280 (74.0)				31	

- ★ 1. Spool type shown in the column is for the centre position.
- ★ 2. Design Standards: None Japanese Standard "JIS" and European Design Standard 90 N. American Design Standard

Graphic Symbols

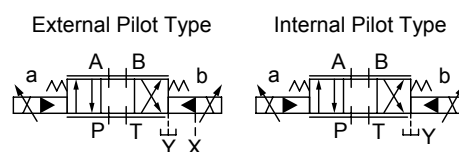

■ Attachment

● Mounting Bolts

Model Numbers	Socket Head Cap Screw			
	Japanese Standard "JIS" European Design Standard	N. American Design Standard	Qty.	Tightening Torque Nm (in. lbs.)
EDFHG-03	M6 × 35 Lg.	1/4-20 UNC × 1-1/2 Lg.	4	12 - 15 (106 - 133)
EDFHG-04	M6 × 45 Lg.	1/4-20 UNC × 1-3/4 Lg.	2	12 - 15 (106 - 133)
	M10 × 50 Lg.	3/8-16 UNC × 2 Lg.	4	58 - 72 (513 - 637)
EDFHG-06	M12 × 60 Lg.	1/2-13 UNC × 2-1/2 Lg.	6	100 - 123 (885 - 1089)

■ Sub-Plates

Valve Model Numbers	Japanese Standard "JIS"			European Design Standard			N. American Design Standard		
	Sub-plate Model Numbers	Thread Size	Approx. Mass kg (lbs.)	Sub-plate Model Numbers	Thread Size	Approx. Mass kg (lbs.)	Sub-plate Model Numbers	Thread Size	Approx. Mass kg (lbs.)
EDFHG-03	DHGM-03Y-10	Rc 3/4	4.7 (10.4)	DHGM-03Y-1080	3/4 BSP.F	4.7 (10.4)	DHGM-03Y-1090	3/4 NPT	4.7 (10.4)
EDFHG-04	DHGM-04-20	Rc 1/2	4.4 (9.7)	DHGM-04-2080	1/2 BSP.F	4.4 (9.7)	DHGM-04-2090	1/2 NPT	4.4 (9.7)
	DHGM-04X-20	Rc 3/4	4.1 (9.0)	DHGM-04X-2080	3/4 BSP.F	4.1 (9.0)	DHGM-04X-2090	3/4 NPT	4.1 (9.0)
EDFHG-06	DHGM-06-50	Rc 3/4	7.4 (16.3)	DHGM-06-5080	3/4 BSP.F	8.5 (18.7)	DHGM-06-5090	3/4 NPT	7.4 (16.3)
	DHGM-06X-50	Rc 1	7.4 (16.3)	DHGM-06X-5080	1 BSP.F	8.5 (18.7)	DHGM-06X-5090	1 NPT	7.4 (16.3)

- Sub-plates are available. Specify the sub-plate model number from the table above. When sub-plates are not used, the mounting surface should have a good machined finish.

■ Applicable Power Amplifiers

For stable performance, it is recommended that Yuken's applicable power amplifiers be used (for details see the Catalogue No. Pub. EC-1305).
Model Numbers: SK1091-D24-10

■ Instructions

● Mounting Position

Be sure to mount the Directional and Flow Control Valve so that the air vents come upside.

[Good example]

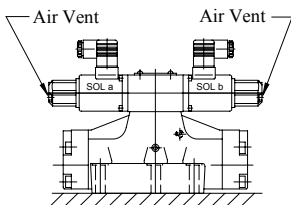

[Bad example]

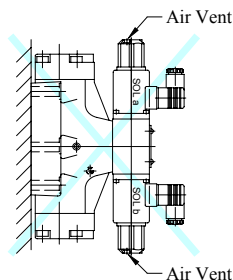

● Manual Adjustment

In the event of an electric fault or emergency, a manual shift can be made by screwing in the manual adjustment screw. Take care, however, that this manual shift has no flows adjusting function.

For this operation, set the pilot pressure (or P-port pressure on an internal-pilot model) below 7 MPa (1020 PSI).

After operation, be sure to return the manual adjustment screw completely to the original position (see the figure right).

● Air Bleeding

To ensure stable control, bleed the air from solenoid completely and fill its icon core with oil. For this purpose, it is recommended to provide the drain line with a check valve having a cracking pressure of about 0.04 MPa (5.8 PSI).

Bleeding can be done by slowly loosening an air vent. There are three air vents. Chose one that appears most helpful (see the figure below).

In addition, be sure to extend the end of the drain line into the oil.

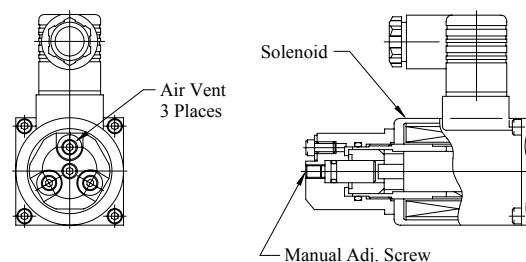

10Ω Series Solenoid

Installation Drawing

EDFHG-03-100-3C*-XY-*-31/3190

Mounting Surface: Main port ... Conform to ISO 4401-AC-05-4-A.
Pilot/drain ports ... Conform to ISO.

★ Of the two tank ports "T", the tank port in the left side is normally used in our standard sub-plate, though, either side of the tank port "T" can be used without problem.

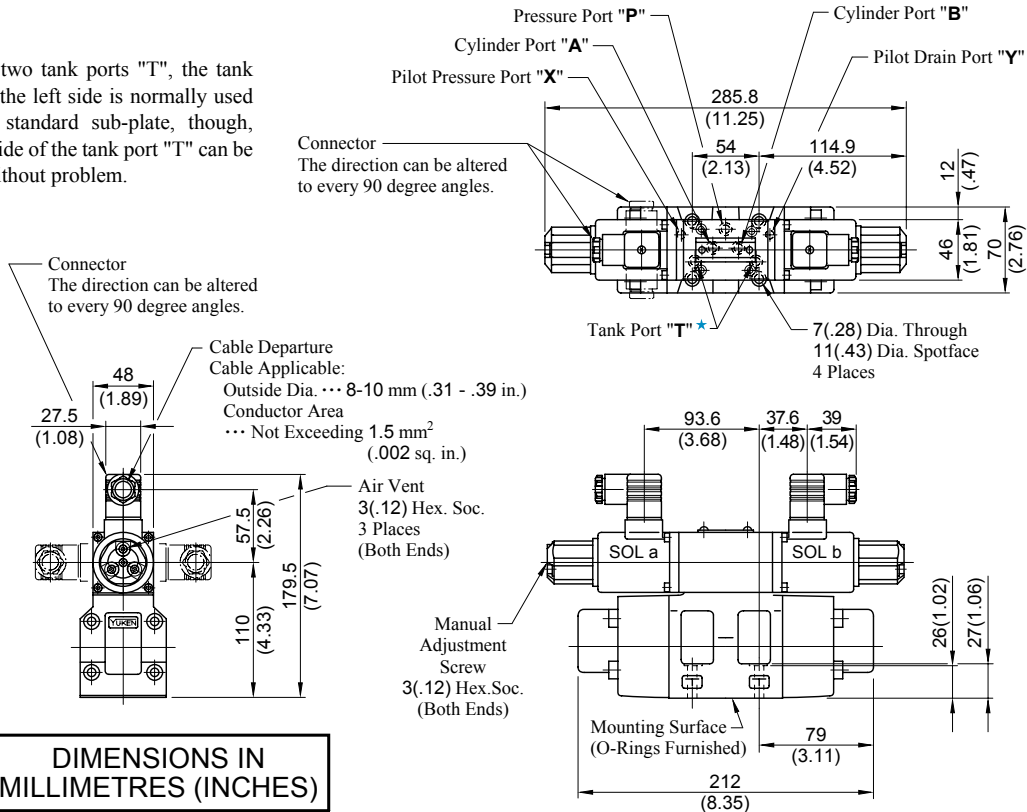

EDFHG-04-140-3C*-XY-*-31/3190

Mounting surface: Conform to ISO4401-AD-07-4-A.

★ Position of cable departure can be changed. For details, refer to above EDFHG-03.

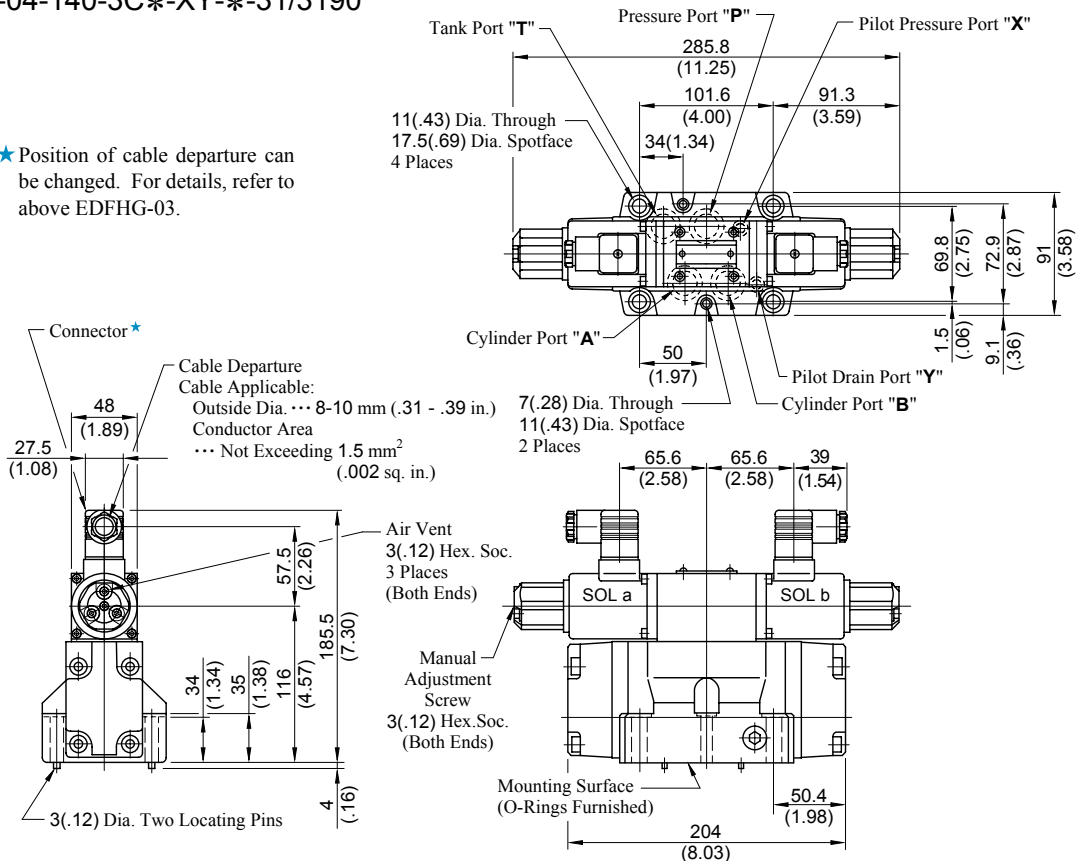

EDFHG-06-280-3C*-XY-*-31/3190

Mounting surface: Conform to ISO4401-AE-08-4-A.

★ Position of cable departure can be changed. For details, refer to EDFHG-03 valve on page 4.

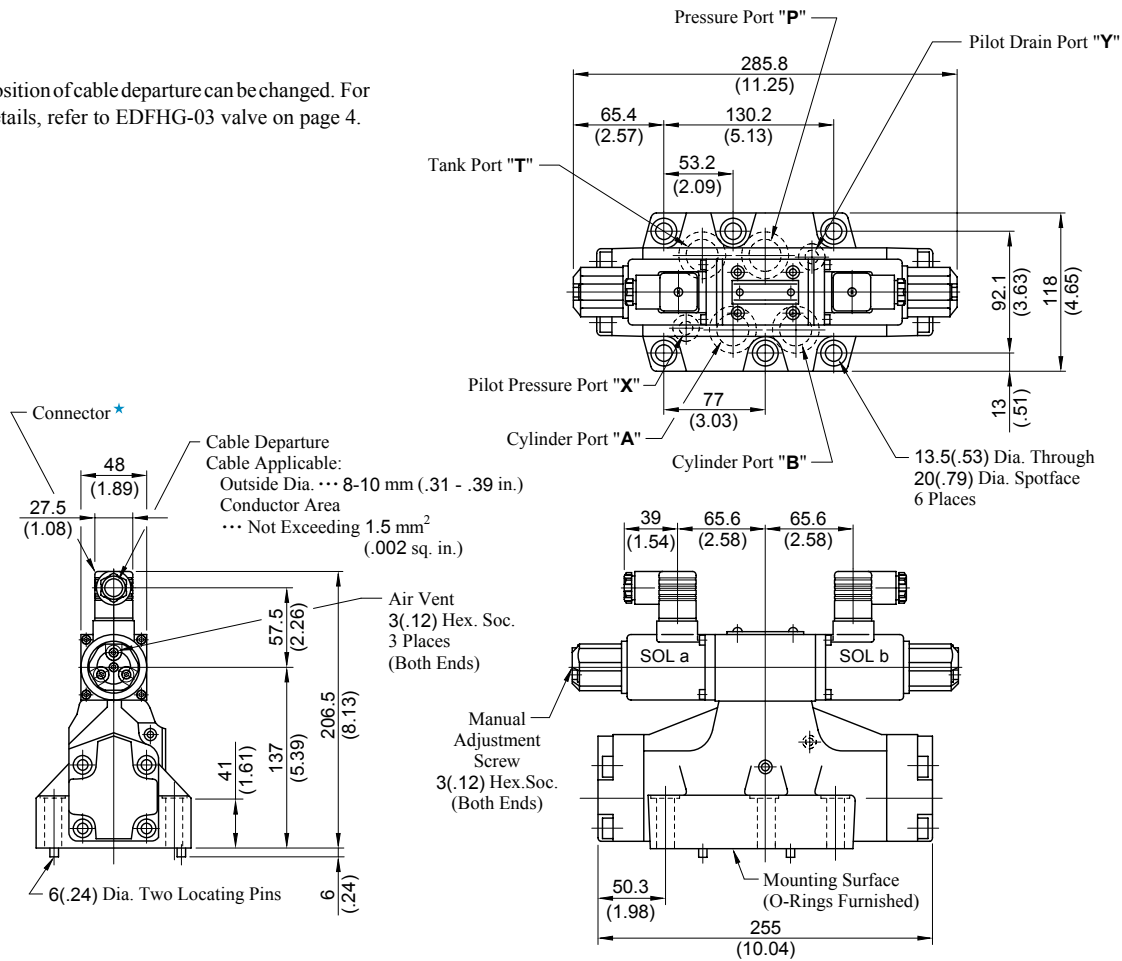

DIMENSIONS IN
MILLIMETRES (INCHES)

■ **Interchangeability between Current and New Design**

● **Specifications and Characteristics**

No changes in specifications and characteristics between current and new design.

● **Mounting Interchangeability**

The mounting surface are interchangeable.

Note that because of improvements made on the solenoids, the overall shapes and dimensions have been changed as shown below.

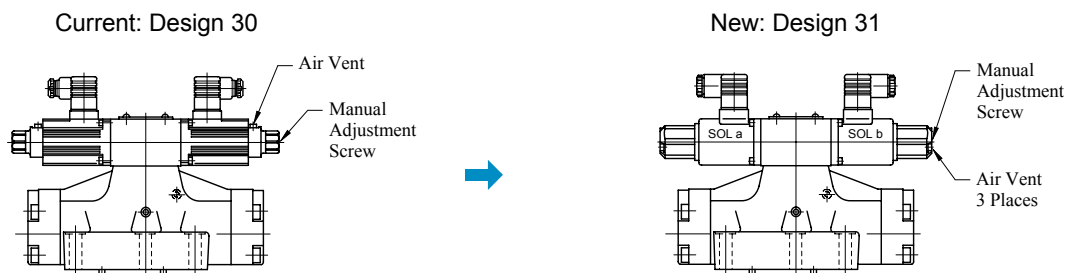

Installation Drawing

■ Sub-Plates

● DHGM-03Y-10/1080/1090

Sub-plate Model Numbers	"C" Thd.	"D" Thd.	"E" Thd.	F mm (in.)
DHGM-03Y-10	Rc 3/4	Rc 1/4	M6	13(.51)
DHGM-03Y-1080	3/4 BSP.F	1/4 BSP.F		
DHGM-03Y-1090	3/4 NPT	1/4 NPT	1/4-20 UNC	15(.59)

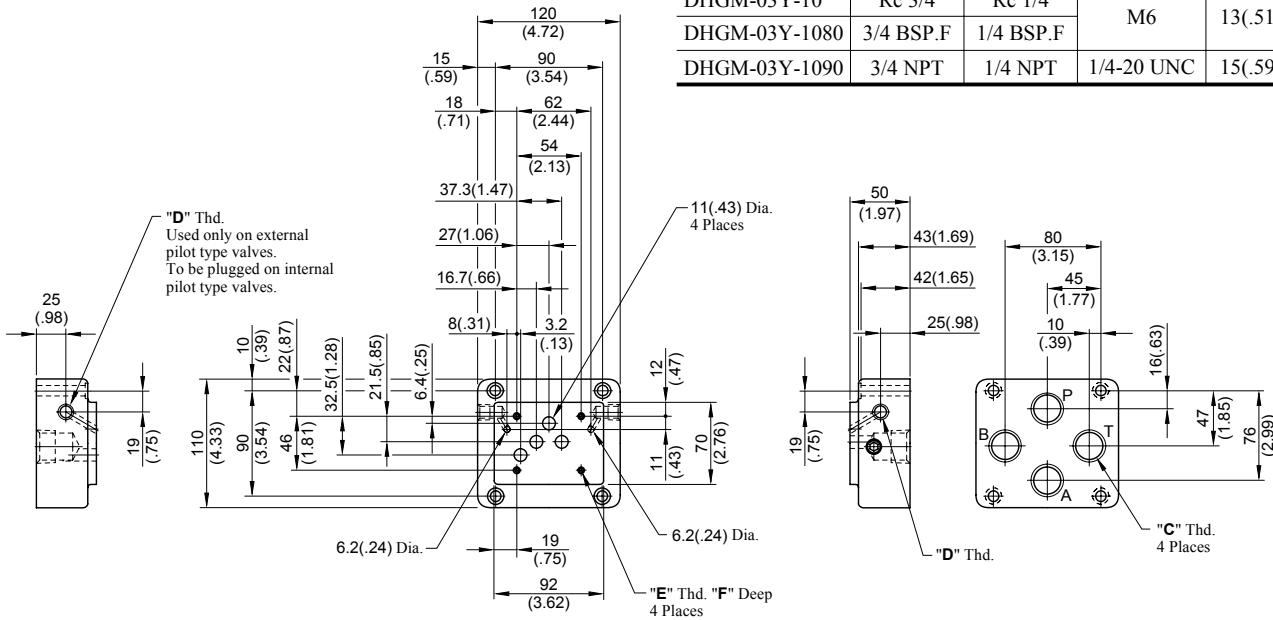

DIMENSIONS IN
MILLIMETRES (INCHES)

● DHGM-04X-20/2080/2090

Sub-plate Model Numbers	"C" Thd.	"D" Thd.	"E" Thd.	"F" Thd.
DHGM-04-20	Rc 1/2	Rc 3/4	M10	M6
DHGM-04X-20	Rc 3/4			
DHGM-04-2080	1/2 BSP.F	1/4 BSP.F	3/8-16 UNC	1/4-20 UNC
DHGM-04X-2080	3/4 BSP.F			
DHGM-04-2090	1/2 NPT	1/4 NPT	3/8-16 UNC	1/4-20 UNC
DHGM-04X-2090	3/4 NPT			

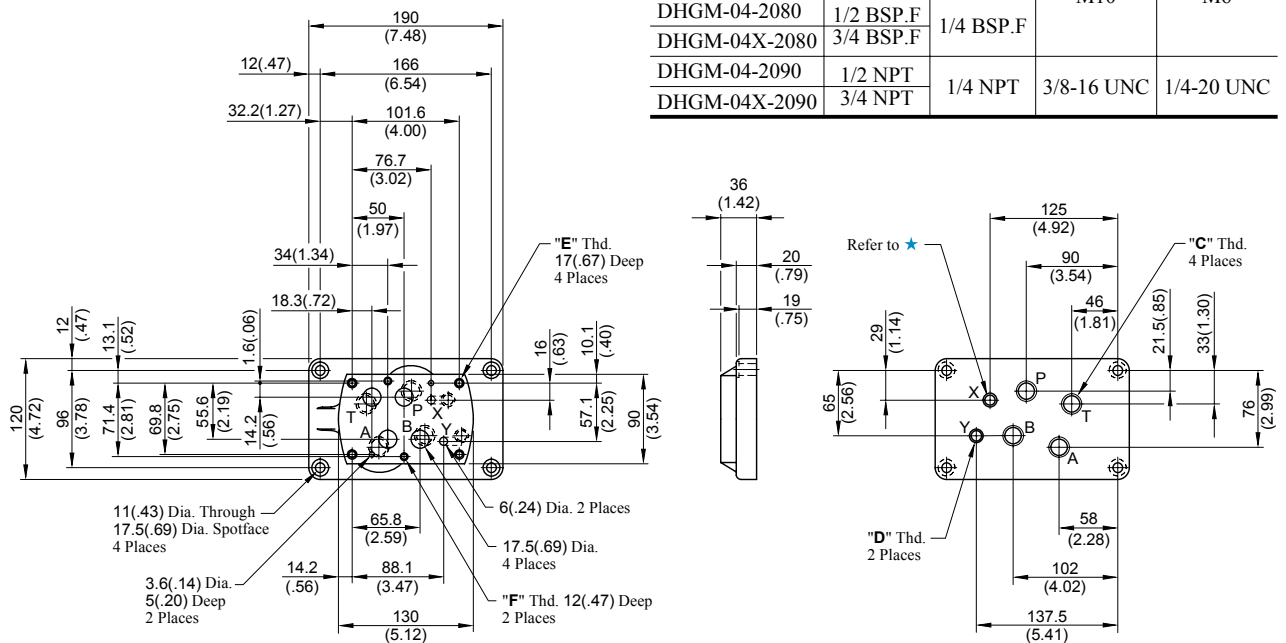

★ Used only on external pilot type valves. To be plugged on internal pilot type valves.

Installation Drawing

Sub-Plates

● DHGM-⁰⁶_{06X}-50/5090

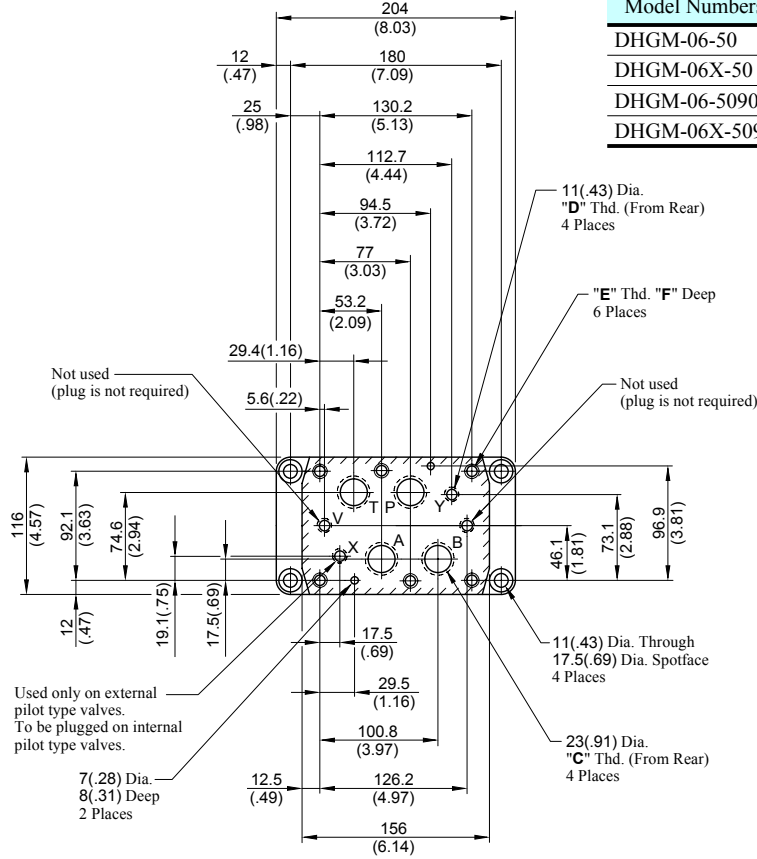

Sub-plate Model Numbers	"C" Thd.	"D" Thd.	"E" Thd.	F mm (in.)
DHGM-06-50	Rc 3/4	Rc 1/4	M12	24 (.94)
DHGM-06X-50	Rc 1			
DHGM-06-5090	3/4 NPT	1/4 NPT	1/2-13 UNC	26 (1.02)
DHGM-06X-5090	1 NPT			

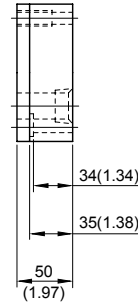

DIMENSIONS IN MILLIMETRES (INCHES)

● DHGM-⁰⁶_{06X}-5080

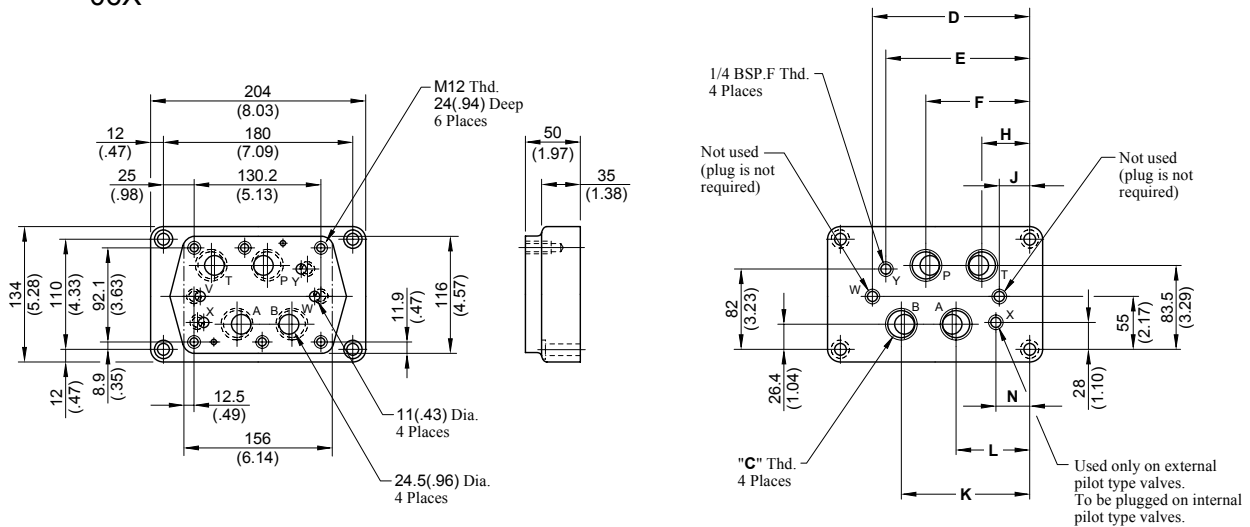

Sub-plate Model Numbers	"C" Thd.	Dimensions mm (Inches)							
		D	E	F	H	J	K	L	N
DHGM-06-5080	3/4 BSP.F	151.2 (5.95)	137.7 (5.42)	102 (4.02)	54.4 (2.14)	30.6 (1.20)	125.8 (4.95)	78.2 (3.08)	42.5 (1.67)
DHGM-06X-5080	1 BSP.F	155.2 (6.11)	148 (5.83)	106 (4.17)	50 (1.97)	25 (.98)	130 (5.12)	74 (2.91)	32 (1.26)

For other dimensions, refer to "DHGM-06*-50/5090" above.



Typical Performance Characteristics

Input Current vs. Flow

Viscosity : 30 mm²/s (141 SSU)

Valve Pres. Difference : P→A (B), B(A)→T 1 MPa (145 PSI)

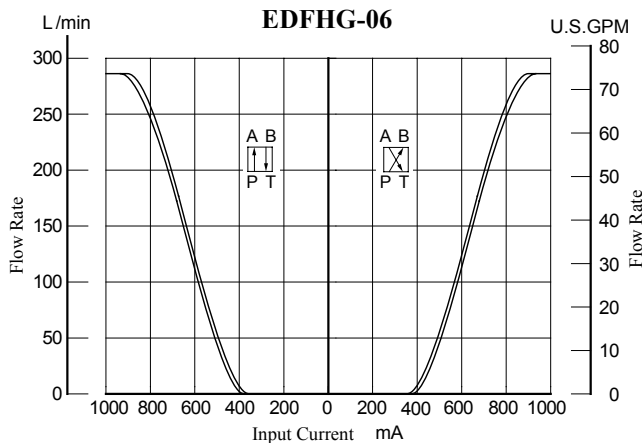
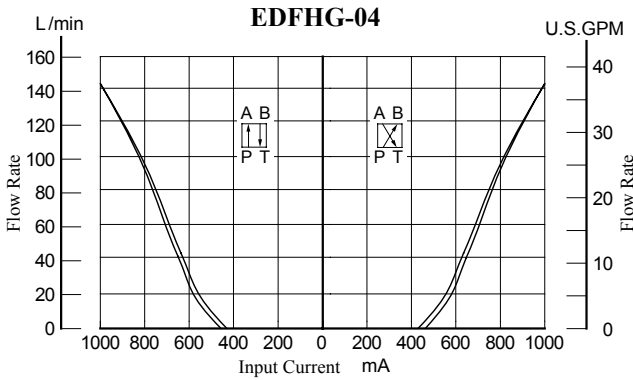
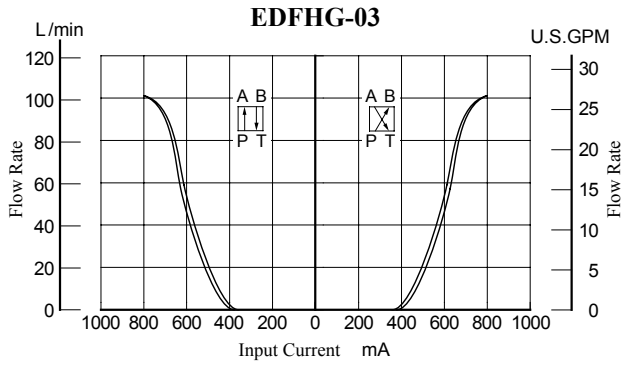

Valve Pressure Difference vs. Flow

Viscosity : 30 mm²/s (141 SSU)

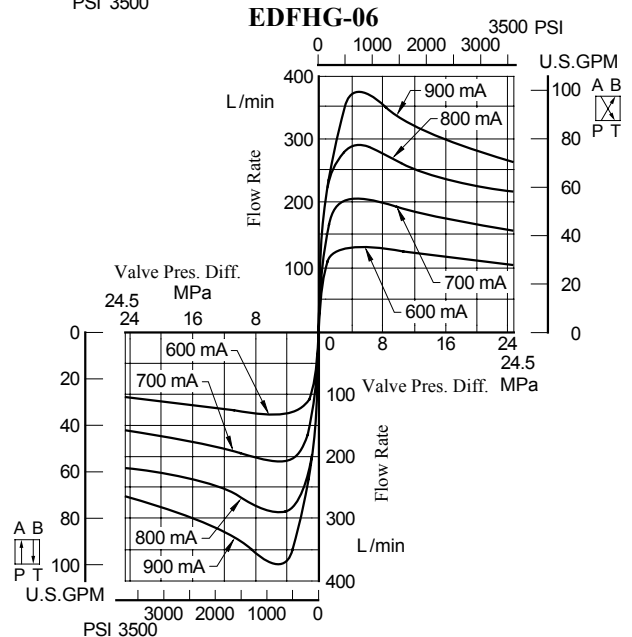
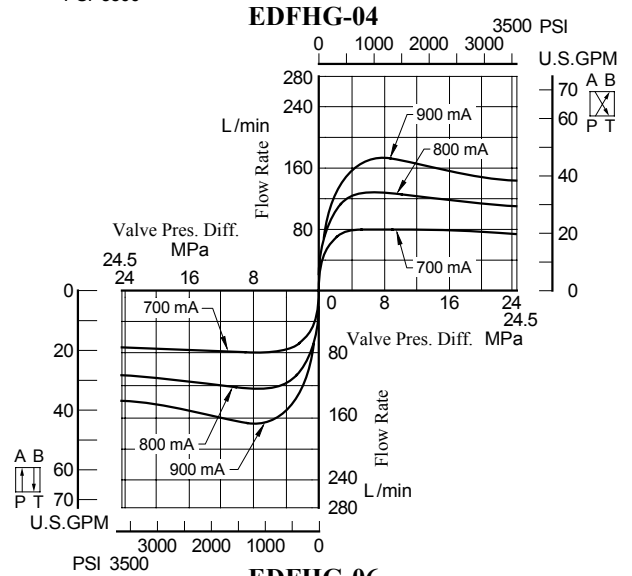
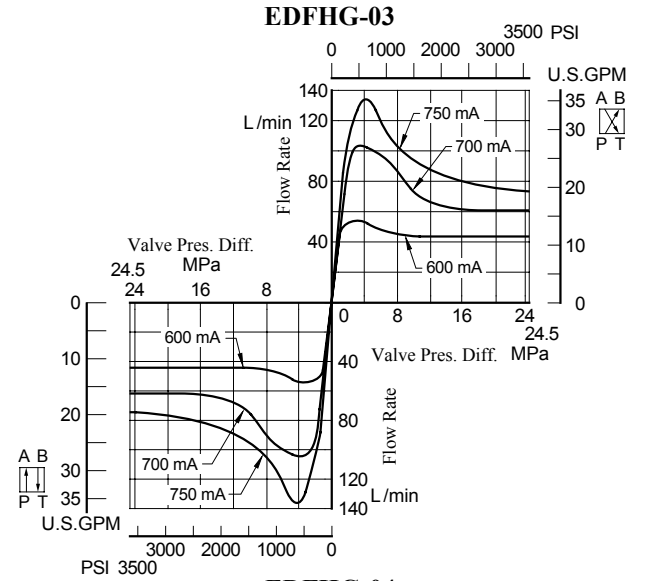

Typical Performance Characteristics

Frequency Response

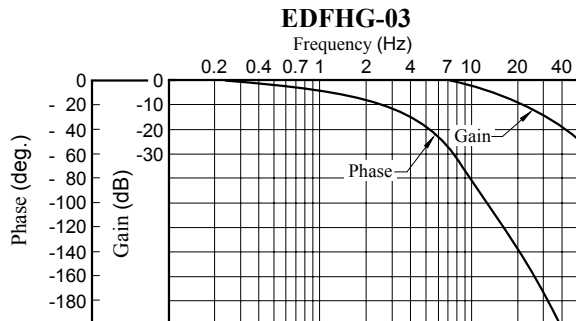

Model Number : EDFHG-03-100-3C2-E-31
 Viscosity : 30 mm²/s(141 SSU)
 Pilot Pressure : 15.7 MPa(2275 PSI)
 Travel of Spool : ±10% of Maximum Stroke

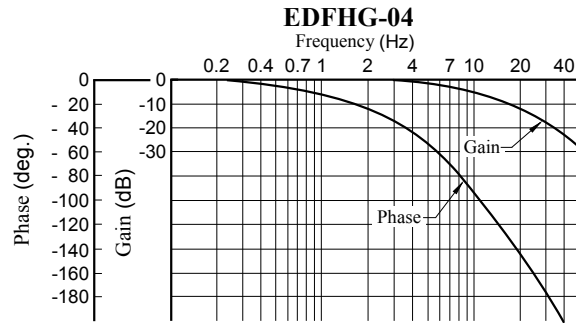

Model Number : EDFHG-04-140-3C2-E-31
 Viscosity : 30 mm²/s(141 SSU)
 Pilot Pressure : 15.7 MPa(2275 PSI)
 Travel of Spool : ±10% of Maximum Stroke

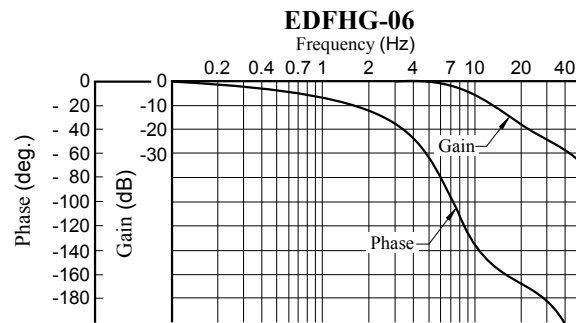

Model Number : EDFHG-06-280-3C2-E-31
 Viscosity : 30 mm²/s(141 SSU)
 Pilot Pressure : 15.7 MPa(2275 PSI)
 Travel of Spool : ±10% of Maximum Stroke

Step Response

These characteristics have been obtained by measuring on each valve. Therefore, they may vary according to a hydraulic circuit to be used.

Viscosity : 30 mm²/s(141 SSU)
 Supply Pressure : 15.7 MPa(2275 PSI)

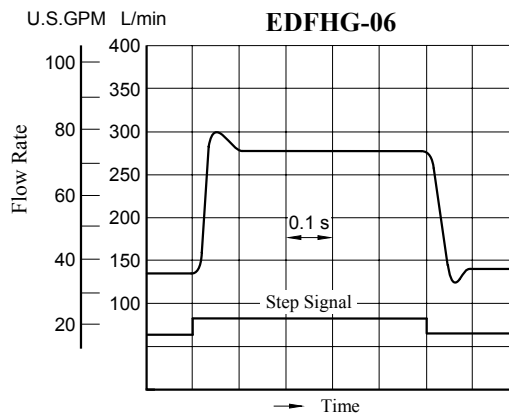
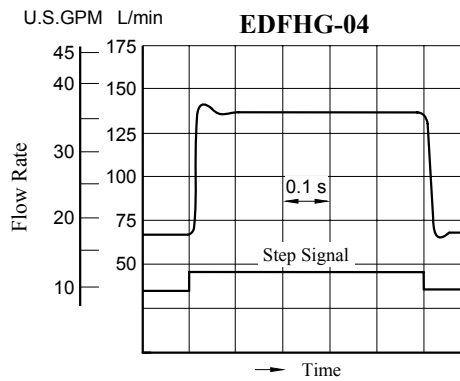
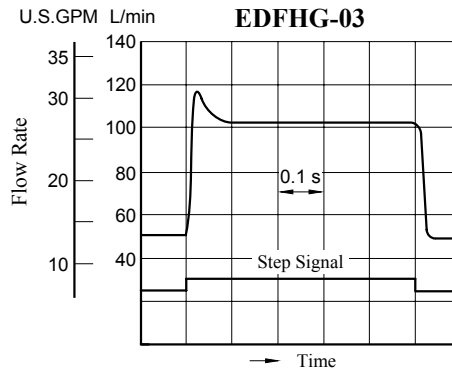

Spare Parts List

EDFHG-03-100-3C*-XY-*-31/3190
 EDFHG-04-140-3C*-XY-*-31/3190
 EDFHG-06-280-3C*-XY-*-31/3190

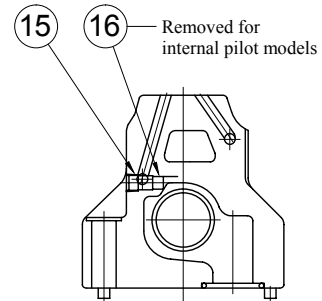
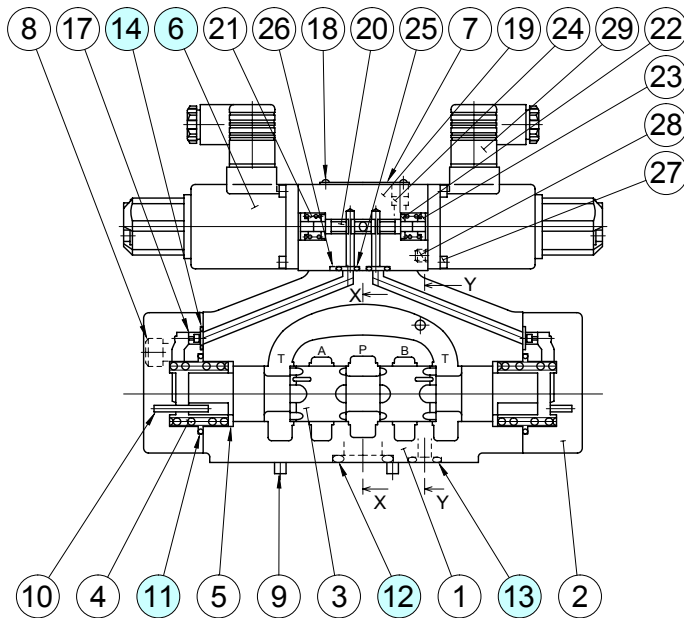

Section X-X

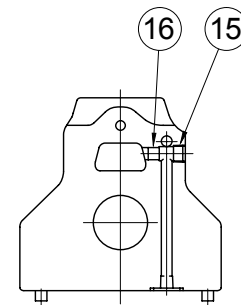

Section Y-Y

List of Seals & Solenoid Ass'y

Item	Name of Parts	EDFHG-03		EDFHG-04		EDFHG-06	
		Part Numbers	Qty.	Part Numbers	Qty.	Part Numbers	Qty.
6	Solenoid Ass'y	E318-Y06M1-28-61	2	E318-Y06M1-28-61	2	E318-Y06M1-28-61	2
11	O-Ring	SO-NB-P28	2	SO-NB-P34	2	SO-NB-P40	2
12	O-Ring	SO-NB-A014	5	SO-NB-P22	4	SO-NB-P30	4
13	O-Ring	SO-NB-P9	2	SO-NB-P9	2	SO-NB-P14	2
14	O-Ring	SO-NB-P9	6	SO-NB-P9	2	SO-NB-P10	2
25	O-Ring	SO-NB-P9	4	SO-NB-P9	4	SO-NB-P9	4
26	O-Ring	SO-NB-P4	2	SO-NB-P4	2	SO-NB-P4	2

Note: The GDM-211-B-11 connector assembly is not included in the solenoid assembly.

When ordering seals, please specify the seal kit number from the table below. In addition to the above o-rings, o-rings for solenoid ass'y are included in the seal kit.

For the detail of the solenoid ass'y o-rings, see the Catalogue No. Pub. EC-1302.

List of Seal Kits

Model Numbers	Seal Kit Numbers
EDFHG-03	KS-EDFHG-03-31
EDFHG-04	KS-EDFHG-04-31
EDFHG-06	KS-EDFHG-06-31

CAUTION

When making replacement of seals, please do it carefully after reading through the relevant instructions in the Operator's Manual.