



**SHUT-OFF TYPE  
SOLENOID OPERATED DIRECTIONAL VALVES  
DSPC/DSPG-01/03(1/8, 3/8)  
Cartridge Type / Sub-plate Mounting**

**DIRECTIONAL  
CONTROLS**

**Up to 25 MPa (3630 PSI), 80 L/min (21.1 U.S.GPM)**

The shut-off type solenoid operated directional valves are poppet type solenoid operated two-way directional valves developed to meet the needs of this age such as energy and resources saving.

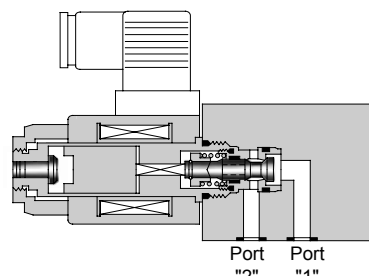
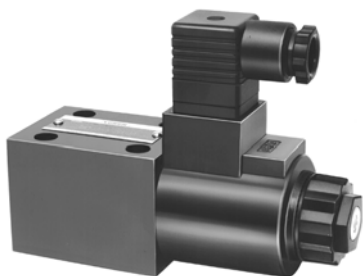

Graphic Symbol

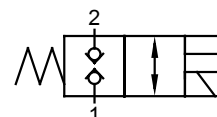

- **High-response**  
High response is provided by the poppet design.
- **Smallest internal leakage**  
Internal leakage are very small, less than 5 drips per min., which is achieved by the poppet design.
- **Two mounting types: cartridge and sub-plate**  
Mounting dimensions for both types conform to ISO standard.
- **Water-proof type (conforming to JIS D 0203 Water Spray Test 32) is also available.**

■ Specifications

Model Numbers	Max. Flow L/min (U.S.GPM)	Max. Operating Pressure			Max. Changeover Frequency min <sup>-1</sup> (Cycles/Min)	Internal leakage cm <sup>3</sup> /min (cu.in./min)	Approx. Mass kg(lbs.)	
		Port "1"★ <sup>2</sup>		Port "2"			AC	DC
		"1" to "2" Flow	"2" to "1" Flow					
DSPC-01-C-*-20*★ <sup>3</sup>	40 (10.6)	10 (1450)	16 (2320)	25 (3630)	300	Less than 0.25 (.015)	0.45 (1.0)	0.6 (1.3)
DSPG-01-C-*-20*★ <sup>3</sup>							1.45 (3.2)	1.6 (3.5)
DSPC-03-C-*-10*★ <sup>3</sup>	80 (21.1)	10 (1450)	16 (2320)	25 (3630)	240	Less than 0.25 (.015)	0.9 (2.0)	1.0 (2.2)
DSPG-03-C-*-10*★ <sup>3</sup>							3.8 (8.4)	3.9 (8.6)

- ★ 1. Maximum flow rates depend on operating conditions. For details, see page 3.
- ★ 2. Do not connect port "1" to a line subjected to surge pressures. In addition, if you use port "1" for tank line, be sure to keep the end of the line in the oil.
- ★ 3. Protections against dust and water conform to the international electric standard (IEC) PUBL 529 IP64.



#### Model Number Designation

F-	DSP	G	-01	-C	-D24	-20	*
Special Seals	Series Number	Type of Connection	Valve Size	Valve Type	Coil Type	Design Number	Design Standard
<b>F:</b> Special Seals for Phosphate Ester Type Fluids (Omit if not required)	<b>DSP:</b> Shut-Off Type Solenoid Operated Directional Valves	<b>C:</b> Cartridge Type  <b>G:</b> Sub-plate Mounting	01	<b>C:</b> Normally Closed	<b>AC</b> <b>A 100</b> <b>A 200</b>  <b>DC</b> <b>D12</b> <b>D24</b>	20	<b>None:</b> Japanese Std. "JIS" & European Design Std. <b>90:</b> N. American Design Std.
			03			10	

#### Solenoid Ratings

Electric Source	Coil Type	Frequency (Hz)	Voltage (V)		Current & Power at Rated Voltage					
			Source Rating	Serviceable Range	Inrush (A) <sup>★1</sup>		Holding (A)		Power (W)	
					01	03	01	03	01	03
AC	A100	50	100	80 - 110	2.42	5.37	0.51	0.90	—	—
		60	100	90 - 120	2.14	4.57	0.37	0.63		
			110		2.35	5.03	0.44	0.77		
	A200	50	200	160 - 220	1.21	2.69	0.25	0.45		
		60	200	180 - 240	1.07	2.29	0.19	0.31		
			220		1.18	2.52	0.22	0.38		
DC <sup>★2</sup> (K Series)	D12	—	12	10.8 - 13.2	—	—	2.45	3.16	29	38
	D24		24	21.6 - 26.4			1.23	1.57		

★1. Inrush current in the above table show rms values at maximum stroke.

★2. K-Series DC Solenoid which has a reputation for excellent DC control is employed.

#### Sub-plate

Model Numbers	Japanese Standard "JIS"		European Design Standard		N.American Design Standard		Approx. Mass kg (lbs.)
	Sub-plate Model Numbers	Thread Size	Sub-plate Model Numbers	Thread Size	Sub-plate Model Numbers	Thread Size	
DSPG-01	DSGM-01-30	Rc 1/8	DSGM-01-3080	1/8 BSP.F	DSGM-01-3090	1/8 NPT	0.8 (1.8)
	DSGM-01X-30	Rc 1/4	DSGM-01X-3080	1/4 BSP.F	DSGM-01X-3090	1/4 NPT	0.8 (1.8)
	DSGM-01Y-30	Rc 3/8	—	—	DSGM-01Y-3090	3/8 NPT	0.8 (1.8)
DSPG-03	DSGM-03-40	Rc 3/8	DSGM-03-2180	3/8 BSP.F	DSGM-03-2190	3/8 NPT	3.0 (6.6)
	DSGM-03X-40	Rc 1/2	DSGM-03X-2180	1/2 BSP.F	DSGM-03X-2190	1/2 NPT	3.0 (6.6)
	DSGM-03Y-40	Rc 3/4	DSGM-03Y-2180	3/4 BSP.F	DSGM-03Y-2190	3/4 NPT	4.7 (10.4)

● Sub-plates are available. Specify the sub-plate model number from the table above. When sub-plates are not used, the mounting surface should have a good machined finish.

#### Mounting Bolts

Four socket head cap screws in the table below are included.

Valve Model Numbers	Descriptions	Soc. Hd. Cap Screw (4 pcs.)	Tightening Torque
DSPG-01	Japanese Standard "JIS" and European Design Standard	M5 × 50 Lg.	5-7 Nm (44 -62 in. lbs.)
	N. American Design Standard	No. 10-24 UNC × 2 Lg.	
DSPG-03	Japanese Standard "JIS" and European Design Standard	M6 × 80 Lg.	12-15 Nm (106 -133 in. lbs.)
	N. American Design Standard	1/4-20 UNC × 3-1/4 Lg.	

### Hydraulic Fluids

#### Fluid Types

Any type of hydraulic fluids listed in the table below can be used.

Petroleum base oils	Use fluids equivalent to ISO VG32 or VG46.
Synthetic fluids	Use phosphate ester or polyol ester fluid. When phosphate ester fluid is used, prefix "F-" to the model number because the special seals (fluororubber) are required to be used.
Water containing fluids	Use water-glycol fluids or W/O emulsion type fluids.

Note: For use with hydraulic fluids other than those listed above, please consult your Yuken representatives in advance.

#### Recommended Viscosity and Oil Temperatures

Viscosity ranging between 15 - 400 mm<sup>2</sup>/s (77 - 1800 SSU).

Oil temperatures between -15/+70°C (5 - 158°F).

Use hydraulic fluids which satisfy the recommended viscosity and oil temperatures given above.

#### Control of Contamination

Due caution must be paid to maintaining control over contamination of the hydraulic fluids which may otherwise lead to breakdowns and shorten the life of the valves. Please maintain the degree of contamination within NAS 1638-Grade 12. Use 25 μm or finer line filter.

### Maximum Flow Rate

The zone under each shaded line denotes the flow rate ranges being free of trouble in changeover.

Typical Performance Characteristics at Viscosity 30 mm<sup>2</sup>/s (141 SSU) [ISO VG 46 oils, 50°C(122 °F)]

#### DSPC/DSPG-01

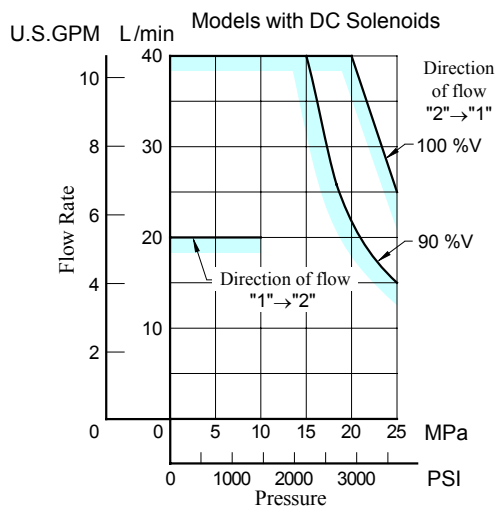
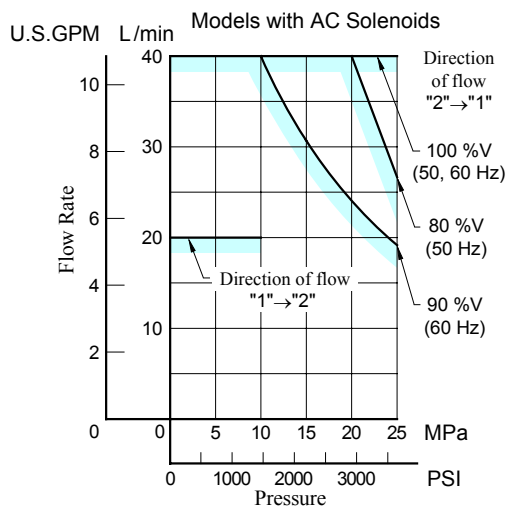

#### DSPC/DSPG-03

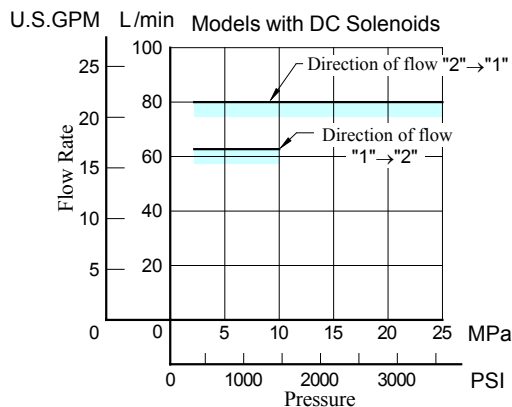
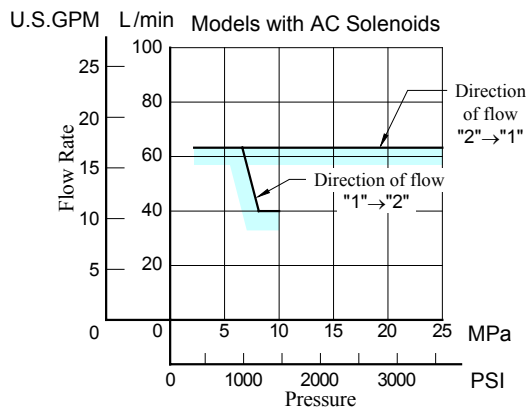

#### Performance Characteristics

Typical Performance Characteristics at Viscosity 30 mm<sup>2</sup>/s (141 SSU) [ISO VG 46 oils, 50°C(122°F)]

#### Typical Changeover Time

##### [Test Conditions]

- Pressure: 15 MPa (2180 PSI)
- Flow Rate: (01) 30 L/min (7.9 U.S.GPM)  
(03) 63 L/min (16.6 U.S.GPM)
- Viscosity: 30 mm<sup>2</sup>/s (141 SSU)
- Voltage: 100 % V (After coil temperature rise and saturates)
- Direction of Flow: "2"→"1"

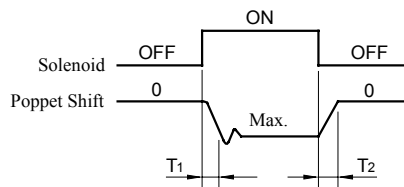

Model Numbers	Shifting Time (ms)	
	T <sub>1</sub>	T <sub>2</sub>
DSPC/DSPG-01-C-A*	22	30
DSPC/DSPG-01-C-D*	69	14
DSPC/DSPG-03-C-A*	22	20
DSPC/DSPG-03-C-D*	60	80

#### Pressure Drop

##### ● DSPC/DSPG-01

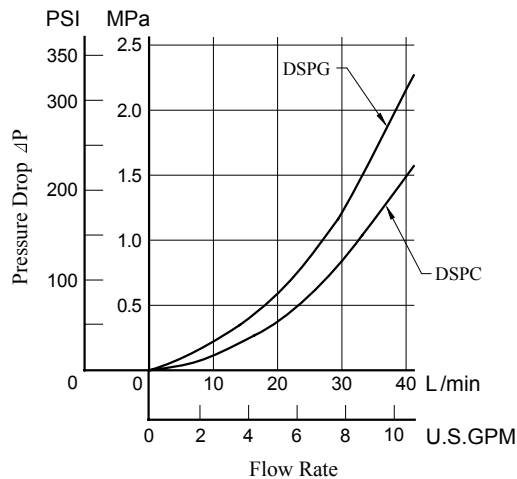

##### ● DSPC/DSPG-03

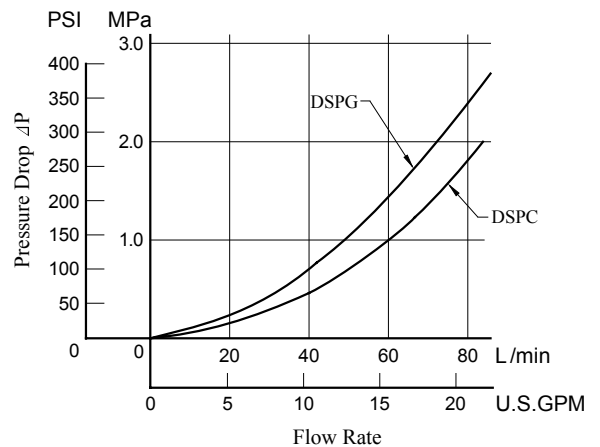

- For any other viscosity, multiply the factors in the table below.

Viscosity	mm <sup>2</sup> /s	15	20	30	40	50	60	70	80	90	100
		SSU	77	98	141	186	232	278	324	371	417
Factor		0.81	0.87	0.96	1.03	1.09	1.14	1.19	1.23	1.27	1.30

- For any other specific gravity (G'), the pressure drop (ΔP') may be obtained from the formula below.

$$\Delta P' = \Delta P(G'/0.850)$$

DSPC-01-C-\* -20/2090

Mounting Surface: ISO 7789 20-01-0-93

#### ● Models with AC Solenoids

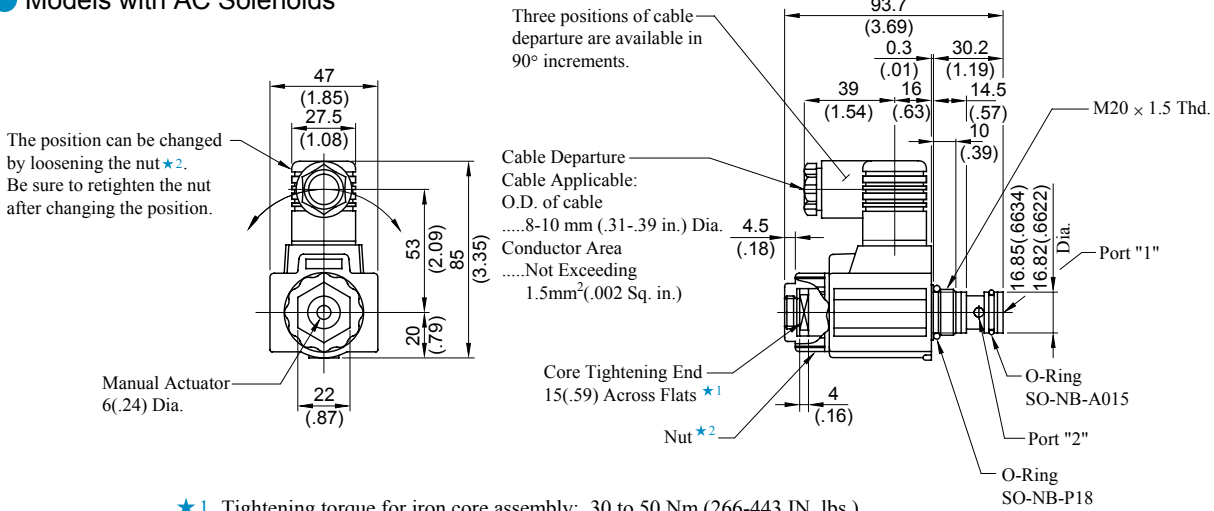

**★1.** Tightening torque for iron core assembly: 30 to 50 Nm (266-443 IN. lbs.)

**★2.** Tightening torque for nuts: 10.3 to 11.3 Nm (91-100 IN. lbs.)

#### ● Models with DC Solenoids

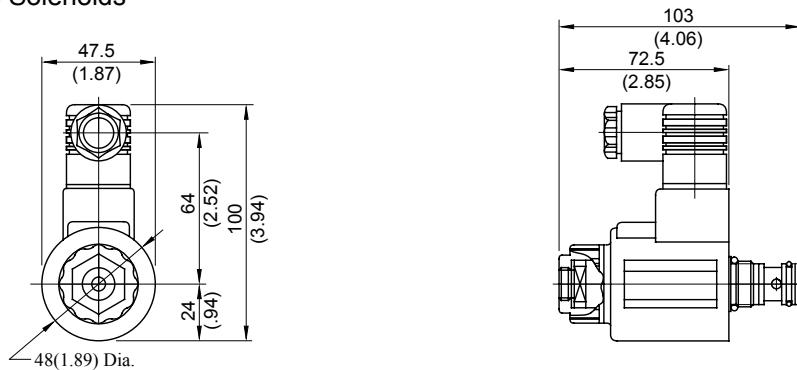

● For other dimensions, refer to the "Models with AC Solenoids".

#### ■ Details of Mounting Holes

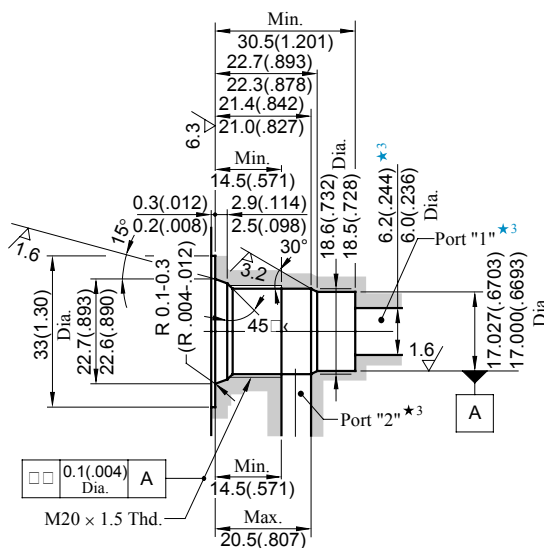

DIMENSIONS IN  
MILLIMETRES (INCHES)

#### ● How to Mount

When mounting, the following steps must be followed.

1. Loosen the coil fastening the nut and remove the coil.
2. Making use of the core tightening end, screw the cartridge in.
3. Attach the coil and fix it with the nut.

**★3.** Port diameter of 6.2 (.244) Dia. recommended.

**★4.** Use iron materials for the mounting section.

DSPC-03-C-\*/-10/1090

Mounting Surface: ISO 7789 27-01-0-93

● Models with AC Solenoids

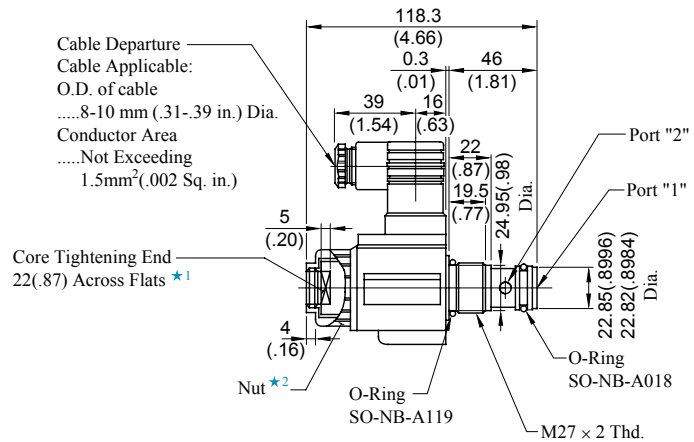
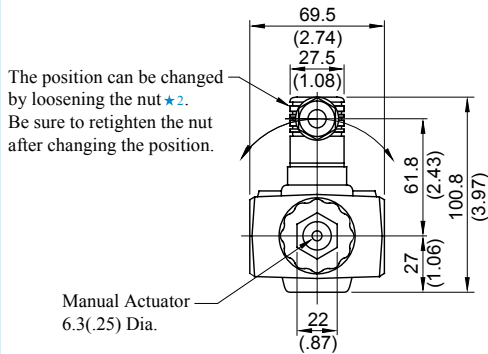

- ★ 1. Tightening torque for iron core assembly: 110-140 Nm (970-1240 IN. lbs.)
- ★ 2. Tightening torque for nuts: 8.5-10.5 Nm (75-93 IN. lbs.)

● Models with DC Solenoids

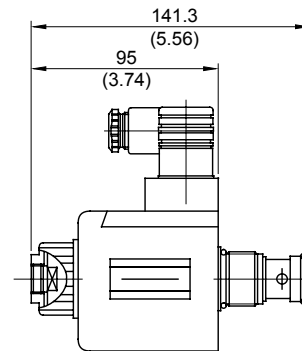
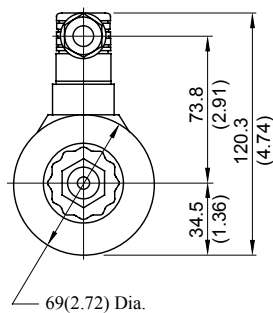

● For other dimensions, refer to the "Models with AC Solenoids".

■ Details of Mounting Holes

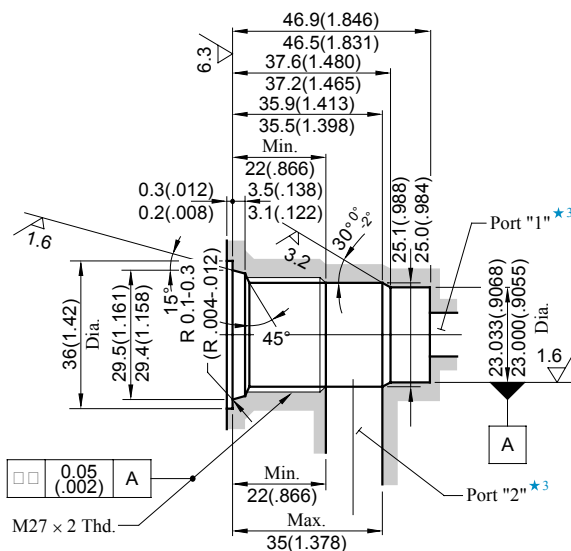

DIMENSIONS IN  
MILLIMETRES (INCHES)

● How to Mount

When mounting, the following steps must be followed.

1. Loosen the coil fastening the nut and remove the coil.
2. Making use of the core tightening end, screw the cartridge in.
3. Attach the coil and fix it with the nut.

- ★ 3. A recommendable port dia. is 11 (433) mm.
- ★ 4. Use iron materials for the mounting section.

DSPG-01-C-\* -20/2090

Mounting Surface: ISO 4401-AB-03-4-A

Models with AC Solenoids

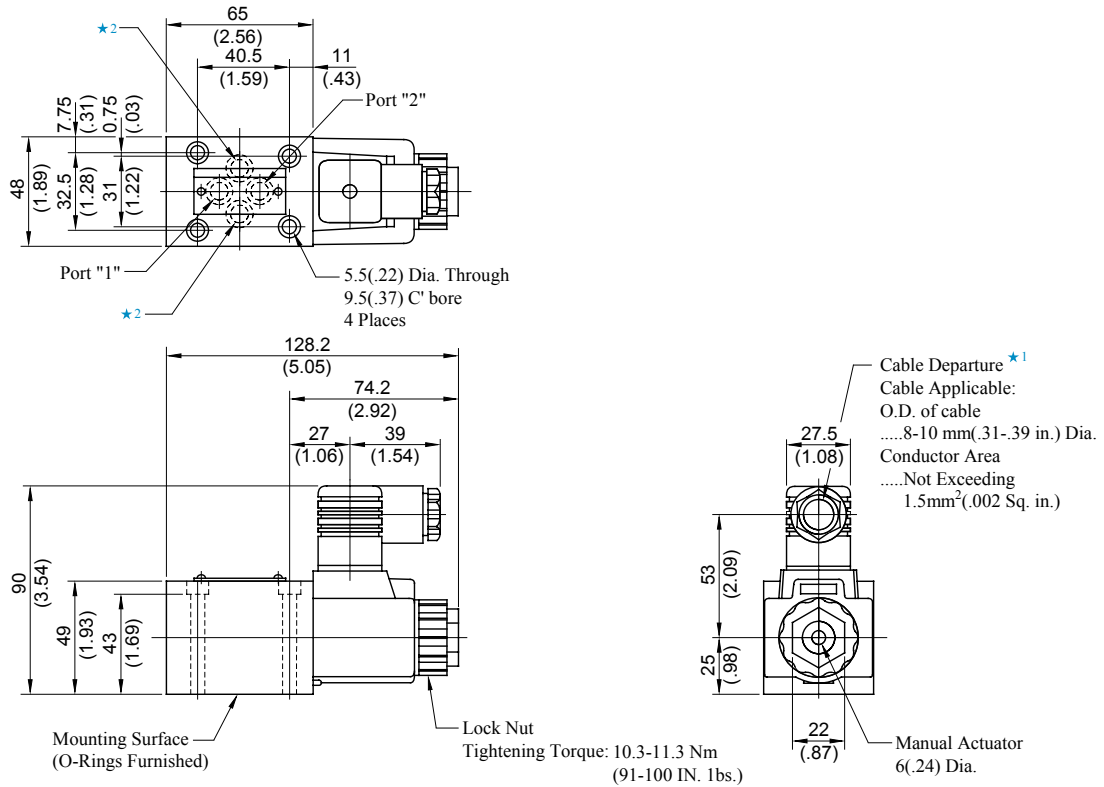

- ★1. The location and the position of the cable departure can be changed. For details, see the cartridge type.
- ★2. These ports (2) are not used. In addition, the body has the O-ring grooves and O-rings are included in the body.
- ★3. The mounting dimensions conform to ISO 4401-AB-03-4-A. Ports A and B are used as ports "2" and "1" respectively.
- ★4. O-rings for ports: SO-NB-P9

DIMENSIONS IN  
MILLIMETRES (INCHES)

Models with DC Solenoids

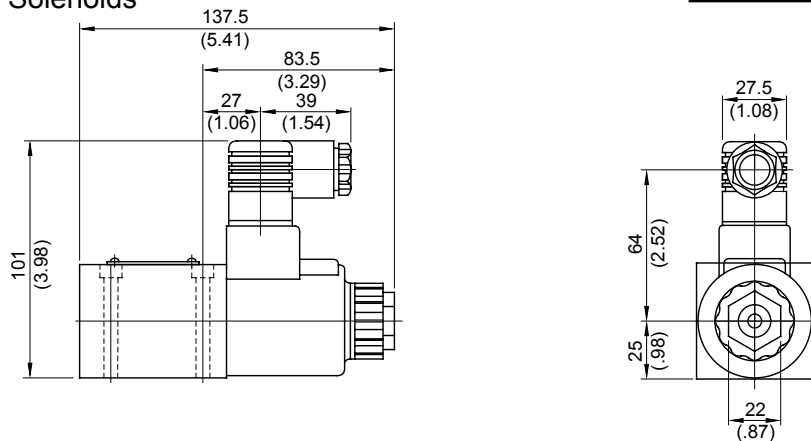

● For other dimensions, refer to the "Models with AC Solenoids".

DSPG-03-C-\*/-10/1090

Mounting Surface: ISO 4401-AC-05-4-A

Models with AC Solenoids

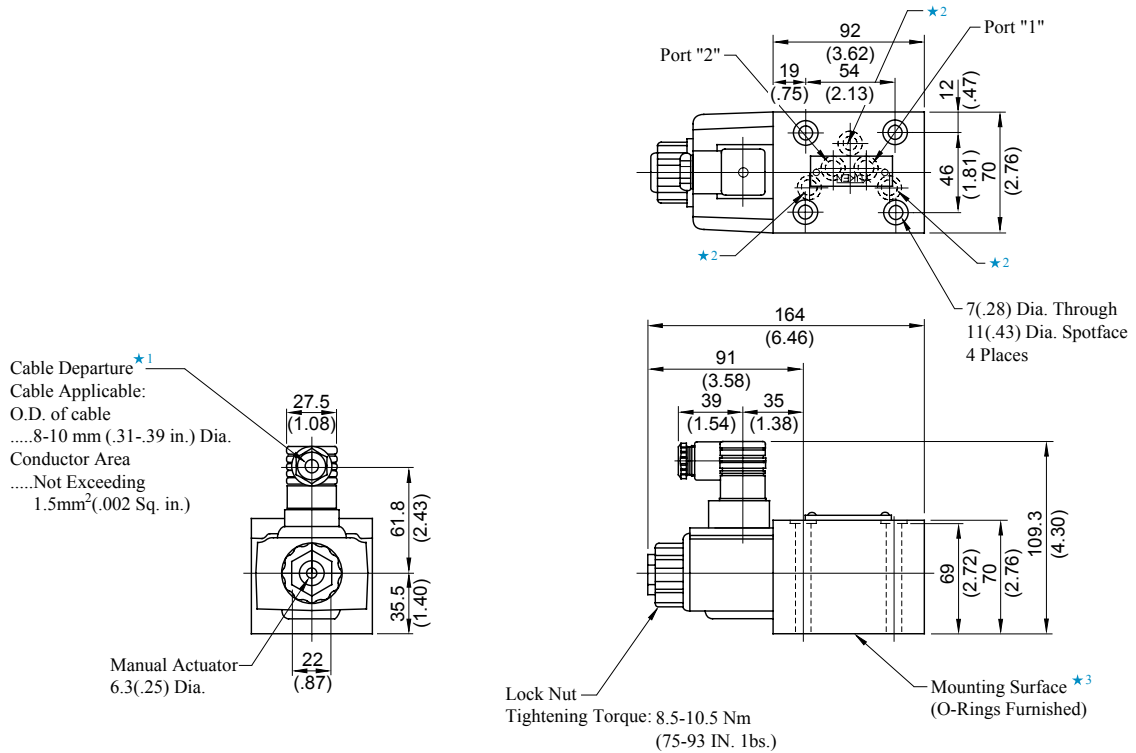

- ★1. The location and the position of the cable departure can be changed. For details, see the cartridge type.
- ★2. These ports (3) are not used. In addition, the body has the O-ring grooves and O-rings are included in the body.
- ★3. The dimensions of mounting surface conform to ISO 4401-AC-05-4-A. Ports A and B are used as port 2 and port 1 respectively.
- ★4. O-rings for each port: SO-NB-A014

DIMENSIONS IN  
MILLIMETRES (INCHES)

Models with DC Solenoids

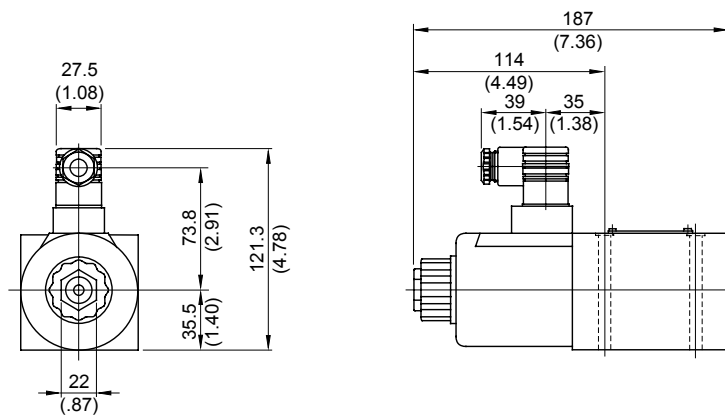

● For other dimensions, refer to the "Models with AC Solenoids".

DSGM-01\*-30/3080/3090

DIMENSIONS IN MILLIMETRES (INCHES)

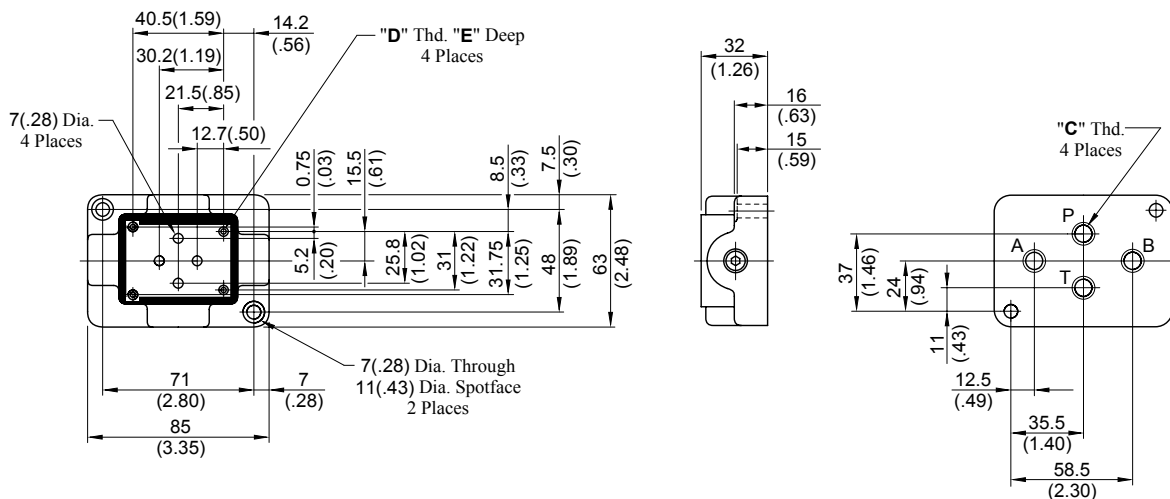

Sub-plate Model Numbers	Thread Size		"E" mm (in.)
	"C" Thd.	"D" Thd.	
DSGM-01-30	Rc 1/8	M5	10 (.39)
DSGM-01-3080	1/8 BSP.F		
DSGM-01-3090	1/8 NPT	No.10-24 UNC	12 (.47)
DSGM-01X-30	Rc 1/4	M5	10 (.39)
DSGM-01X-3080	1/4 BSP.F		
DSGM-01X-3090	1/4 NPT	No.10-24 UNC	12 (.47)
DSGM-01Y-30	Rc 3/8	M5	10 (.39)
DSGM-01Y-3090	3/8 NPT	No.10-24 UNC	12 (.47)





#### Spare Parts List

#### ⚠ CAUTION

When making replacement of seals or solenoid assemblies, do it carefully after reading through the relevant instructions in the Operator's Manual.

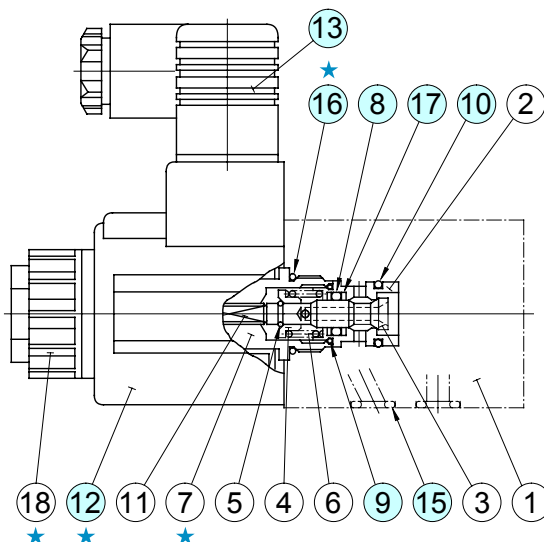

Solenoid assembly is composed of the parts marked with ★.

#### ● List of Seals

Item	Name of Parts	DSP*-01		DSP*-03		Remarks
		Part Numbers	Qty.	Part Numbers	Qty.	
8	O-Ring	SO-NA-P8	1	SO-NA-P12	1	———
9	O-Ring	SO-NB-A014	1	SO-NB-A017	1	———
10	O-Ring	SO-NB-A015	1	SO-NB-A018	1	———
15	O-Ring	SO-NB-P9	4	SO-NB-A014	5	———
16	O-Ring	SO-NB-P18	1	SO-NB-A119	1	only for "DSPG"
17	Back Up Ring	5701-VK413831-9	2	2691-VK418550-0	2	———

Note: When ordering the seals, specify the seal kit number from the table below.

#### ● Solenoid Ass'y, Coil Ass'y and Connector Ass'y No.

Valve Model No.	Solenoid Ass'y No.	⑫ Coil No.	⑬ Connector No.
DSPC/DSPG-01-C-A100-20/2090	SA1-100-N-6055	C-SA1-100-N-60	GDM-211-B-11
DSPC/DSPG-01-C-A200-20/2090	SA1-200-N-6055	C-SA1-200-N-60	
DSPC/DSPG-01-C-D12-20/2090	SD1-12-N-6055	C-SD1-12-N-60	
DSPC/DSPG-01-C-D24-20/2090	SD1-24-N-6055	C-SD1-24-N-60	
DSPC/DSPG-03-C-A100-10/1090	SA3-100-N-5130	C-SA3-100-N-50	
DSPC/DSPG-03-C-A200-10/1090	SA3-200-N-5130	C-SA3-200-N-50	
DSPC/DSPG-03-C-D12-10/1090	SD3-12-N-5130	C-SD3-12-N-50	
DSPC/DSPG-03-C-D24-10/1090	SD3-24-N-5130	C-SD3-24-N-50	

#### ● List of Seal Kits

Valve Model Numbers	Seal Kit Numbers
DSPC-01-C-*-20*	KS-DSPC-01-C-10
DSPC-03-C-*-10*	KS-DSPC-03-C-10
DSPG-01-C-*-20*	KS-DSPG-01-C-10
DSPG-03-C-*-10*	KS-DSPG-03-C-10

#### ⚠ WARNING

Before maintenance or removal, do the following. Failure to do these may cause components to move, causing oil leakage or serious accidents.

- Shut off the equipment's power supply, and be sure that all electric motors and engines have stopped.
- Return pressure in all hydraulic systems to zero.