



**SOLENOID OPERATED
POPPET TYPE TWO-WAY VALVES**
CDST-03W/03 (1/4, 3/8)
CDSC-03 (3/8)
CDSG-03 (3/8)

**DIRECTIONAL
CONTROLS**

Threaded Connections/Cartridge Type/Gasket Mounting

Up to 14 MPa (2030 PSI), 50 L/min (13.2 U.S.GPM)

These valves are used for opening/closing the oil path by having the poppet valve operated with an electric signal via solenoid. Because these are of poppet type, the internal leakage is quite small and there is no worry about hydraulic lock.

Specifications

Model Numbers	Max. Flow L/min (U.S.GPM)	Max. Operating Pressure MPa (PSI)	Internal leakage cm ³ /min (cu.in./min)	Max. Changeover Frequency min ⁻¹ (Cycles/Min)	Approx. Mass kg(1bs.)
CDSC-03-C-*-21*	50* (13.2)	14 (2030)	Less than 0.25 (.015)	AC: 300 DC: 240 R: 120	0.5 (1.1)
CDST-03W-03-C-*-21*					0.85 (1.9)
CDSG-03-C-*-21*					0.85 (1.9)

★ The maximum flow means the limited flow without inducing any abnormality to the operation (changeover) of the valve.

Solenoid Ratings

Electric Source	Coil Type	Frequency (Hz)	Voltage (V)		Current & Power at Rated Voltage		
			Source Rating	Serviceable Range	Inrush (A)	Holding (A)	Power (W)
AC	A100	50	100	80 - 100	1.12	0.55	—
		60	100	90 - 120	0.95	0.40	
		110	—	0.86	0.36		
	A120	50	120	96 - 132	0.93	0.46	
		60		108 - 144	0.79	0.33	
	A200	50	200	160 - 220	0.56	0.28	
				180 - 240	0.48	0.20	
		60	220	0.43	0.18		
			—	—	—	—	
	A240	50	240	192 - 264	0.47	0.23	
60		216 - 288		0.40	0.17		
DC (K Series)	D12	—	12	10.8 - 13.2	—	2.20	26
	D24		24	21.6 - 26.4		1.10	
	D48		48	43.2 - 52.8		0.55	
AC→DC Rectified	R100	50/60	100	90 - 110	—	0.30	26
	R200		200	180 - 220		0.15	

- Because both AC and DC solenoids employ the plug-in type electrical wiring, the valve can be removed without removing the wiring.
- Being 50-60 Hz common service AC solenoids, do not require rewiring when the applied frequency is changed.
- K-Series DC Solenoid which has a reputation for excellent DC control is employed.

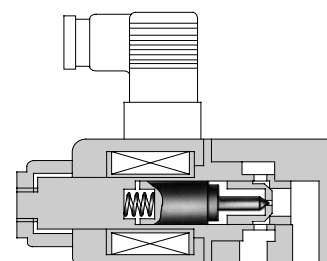

Graphic Symbol

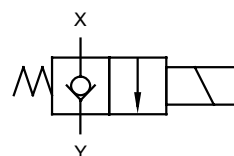

Instructions

● **Direction of flow when the solenoid is energised**

These valves do not allow flow from Y to X when the solenoid is energised.

● **At the time of test run**

At the time of test run, there is a possibility that the oil may not flow even after the solenoid is energised because of the residual air in the valve.

● **Mounting**

There are no mounting restrictions for any models.

■ Model Number Designation

F-	CDS	T	-03	-C	-D12	-21	*
Special Seals	Series Number	Type of Connection	Valve Size	Valve Type	Coil Type	Design Number	Design Standard
F: Special seals for phosphate ester type fluids (Omit if not required)	CDS: Solenoid Operated Poppet Type Two-Way Valves	T: Threaded Connection	03W (Piping Size 1/4) 03 (Piping Size 3/8)	C: Normally Closed	AC A100, A120 A200, A240	21	None: Japanese Std. "JIS" 80: European Design Std. 90: N. American Design Std.
		C: Cartridge Type	03		DC D12, D24 D48		
		G: Gasket Mounting				AC→DC Rectified R100, R200	21

■ Hydraulic Fluids

● Fluid Types

Any type of hydraulic fluids listed in the table below can be used.

Petroleum base oils	Use fluids equivalent to ISO VG 32 or VG46.
Synthetic fluids	Use phosphate ester or polyol ester fluid. When phosphate ester fluid is used, prefix "F-" to the model number because the special seals (fluororubber) are required to be used.
Water containing fluids	Use water-glycol fluids or W/O emulsion type fluids.

Note1: Water-glycol fluids cannot be used for CDST-03/03W and CDSG-03 valves.

2: For use with hydraulic fluids other than those listed above, please consult your Yuken representatives in advance.

● Recommended Viscosity and Oil Temperatures

Viscosity ranging between 15 - 400 mm²/s (77 - 1800 SSU)

Oil temperatures between -15/+70°C (5 - 158°F)

Use hydraulic fluids which satisfy the recommended viscosity and oil temperatures given above.

● Control of Contamination

Due caution must be paid to maintaining control over contamination of the hydraulic fluids which may otherwise lead to breakdowns and shorten the life of the valves. Please maintain the degree of contamination within NAS 1638-Grade 12. Use 25 μm or finer line filter.

■ Mounting Bolts

Mounting bolt in the table below is attached only for Gasket mounting type valve (CDSG-03).

Valve Model Numbers	Socket Head Cap Screws (2pcs.)	
	Japanese Standard "JIS" European Design Standard	N. American Design Standard
CDSG-03	M6 × 60 Lg.	1/4-20 UNC × 2-1/4Lg.

Pressure Drop

Hydraulic Fluid: Viscosity 35 mm²/s (164 SSU), Specific Gravity 0.850

CDSC-03 CDST-03 CDSG-03

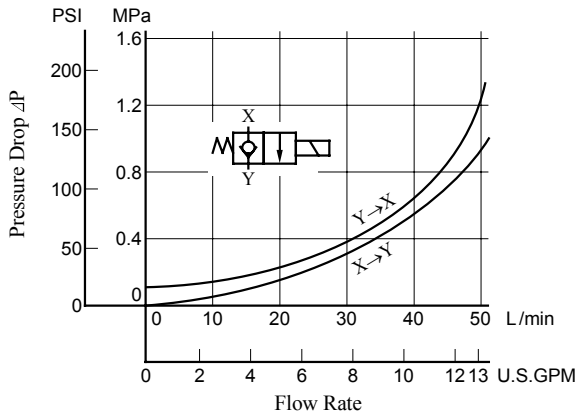

CDST-03W

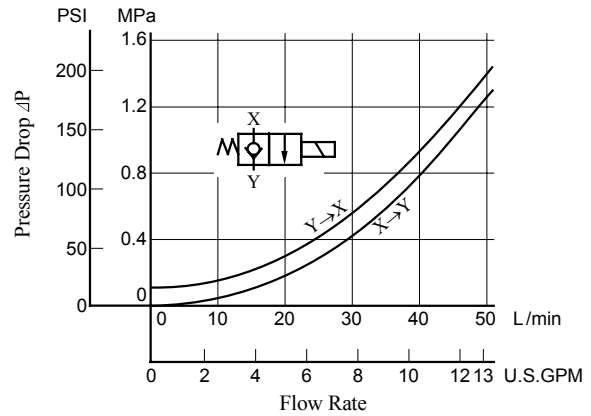

Note: Measuring has been made for the CDSC-03 (Cartridge type) when it is equipped with the same body as the threaded connections and the gasket mounting type.

- For any other viscosity, multiply the factors in the table below.

Viscosity	mm ² /s	15	20	30	40	50	60	70	80	90	100
	SSU	77	98	141	186	232	278	324	371	417	464
Factor		0.81	0.87	0.96	1.03	1.09	1.14	1.19	1.23	1.27	1.30

- For any other specific gravity (G'), the pressure drop (ΔP') may be obtained from the formula below.

$$\Delta P' = \Delta P (G'/0.850)$$

Changeover Time

Changeover time, T2 and T4, in particular, varies according to the hydraulic circuit and operating conditions. As an example, the following figures show how the measurement is made.

Test Circuit

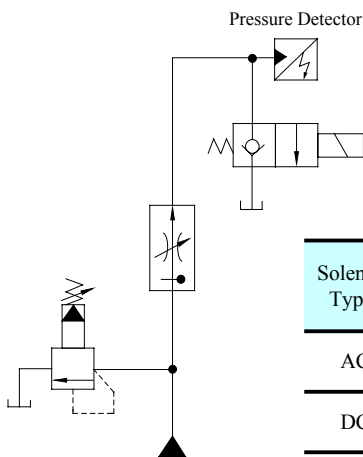

Result of measurement

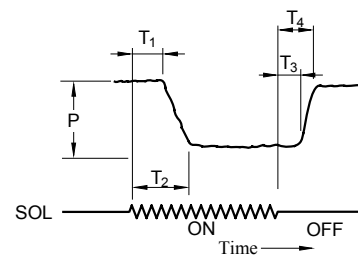

Solenoid Types	Condition		Shifting time (ms)			
	Pressure "P" MPa (PSI)	Flow Rate L/min (U.S.GPM)	SOL "ON"(Close→Open)		SOL "OFF"(Open→Close)	
			T1	T2 (ex.)	T3	T4 (ex.)
AC	7 (1020)	50 (13.2)	10	86	20	44
	14 (2030)	50 (13.2)	11	43	12	54
DC	7 (1020)	50 (13.2)	22	104	44	66
	14 (2030)	50 (13.2)	24	60	41	73
AC→DC Rectified	7 (1020)	50 (13.2)	27	100	114	146
	14 (2030)	50 (13.2)	32	66	108	142

Note: The above changeover time is based on the rated voltage.



CDSC-03-C-A*-21/2190

Models with AC Solenoids

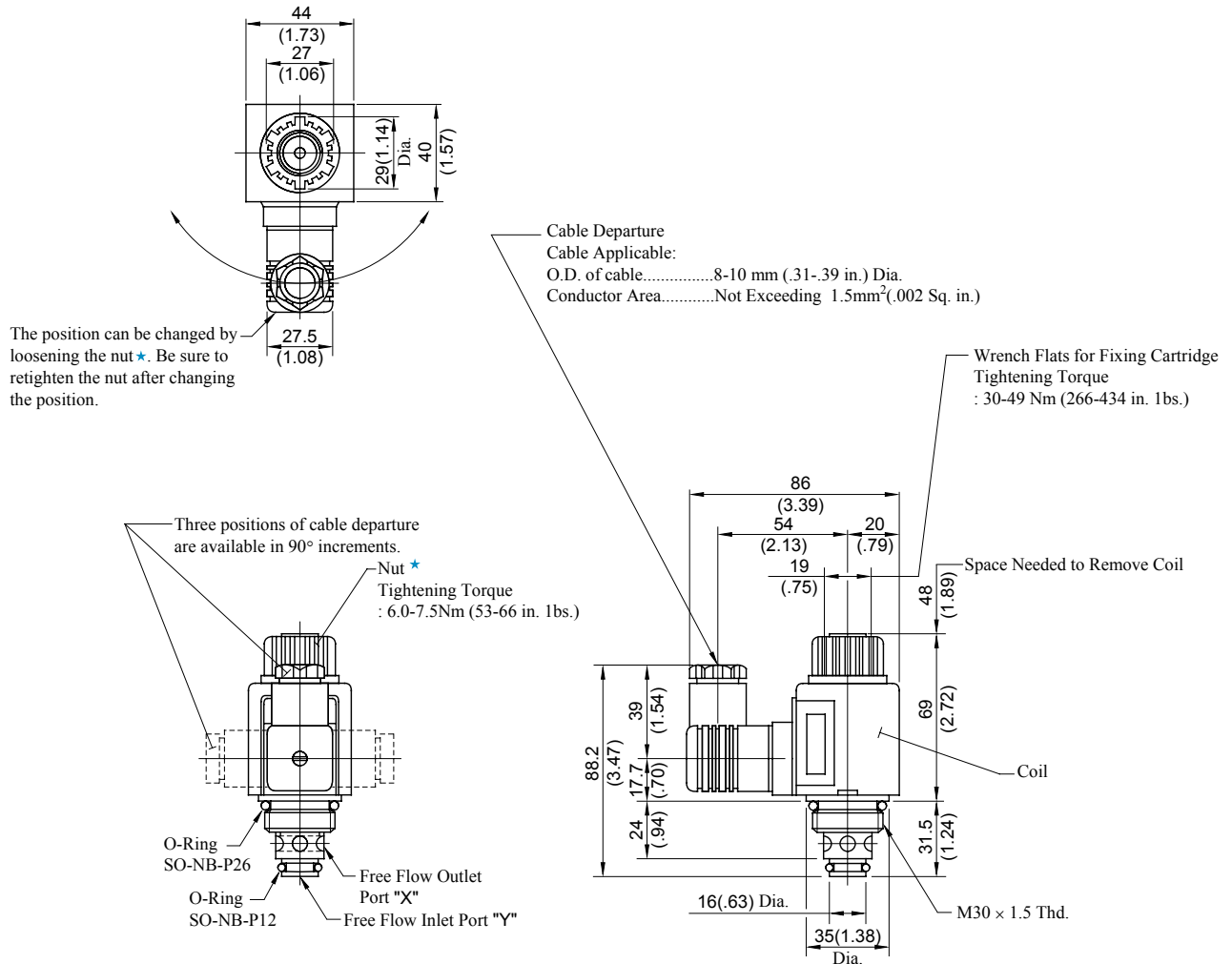

DIMENSIONS IN
MILLIMETRES (INCHES)

Details of Mounting Holes

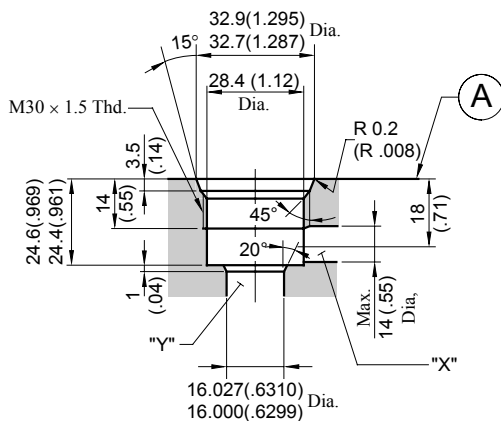

How to Mount

When mounting, the following steps must be followed:

1. Loosen the nut \star , then remove the coil.
2. Thread the cartridge, making sure that the collar 35 (1.38) Dia. of the cartridge is well fitted to the component surface (A surface in the left drawing).
3. Attach the coil and secure it with a nut.

Note: The fitting portion of O-rings should have a good machined finish.

CDSC-03-C-D*-21/2190

Models with DC Solenoids

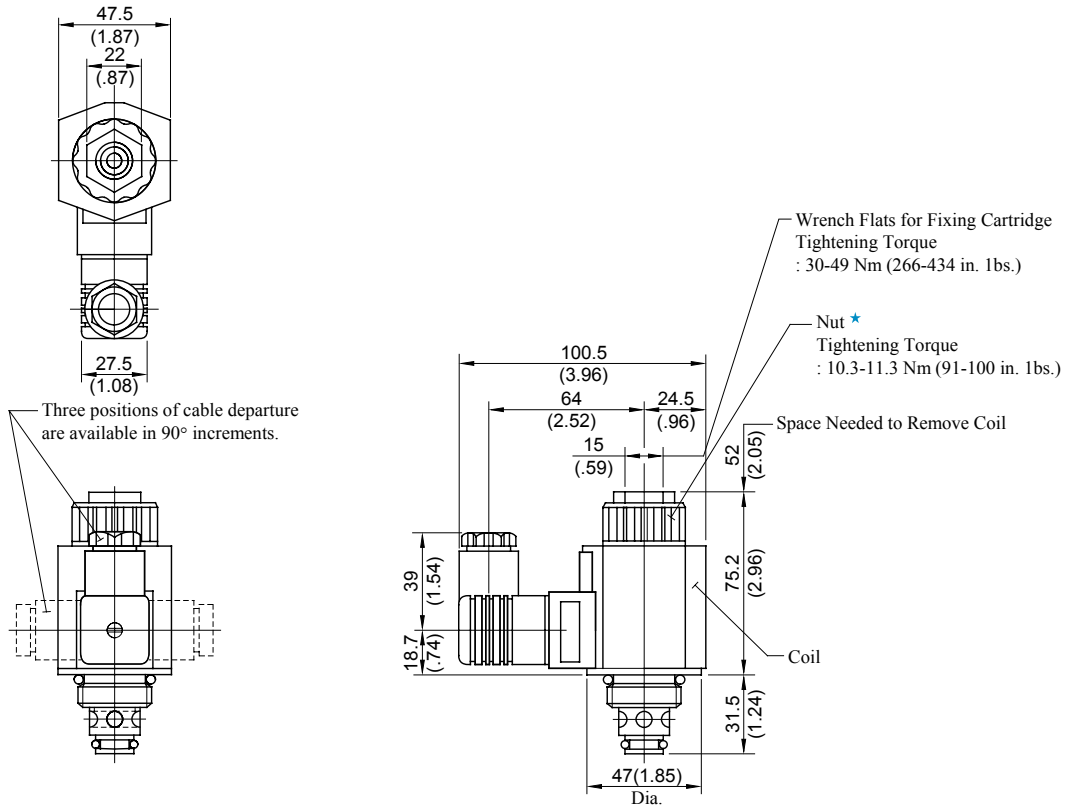

For other dimensions, refer to the "Models with AC Solenoids".

**DIMENSIONS IN
MILLIMETRES (INCHES)**

CDSC-03-C-R*-21/2190

Models with R Type Solenoids

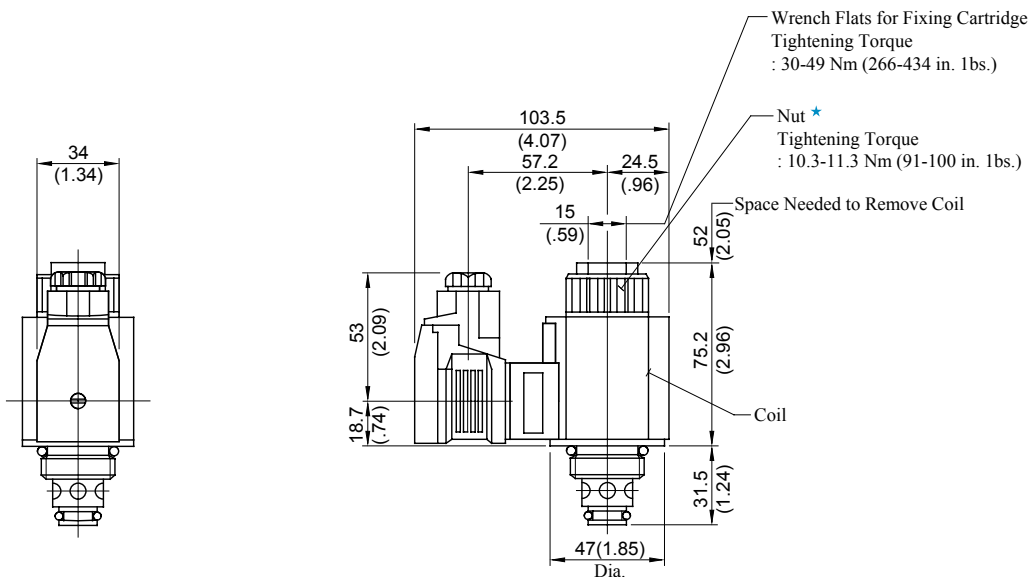

For other dimensions, refer to the "Models with AC Solenoids".



Solenoid Operated Poppet Type Two-Way Valves CDST/CDSG-03(03W) Threaded Connections / Gasket Mounting

Installation Drawings

CDST-03, 03W-C-*21/2180/2190

Models with AC Solenoids

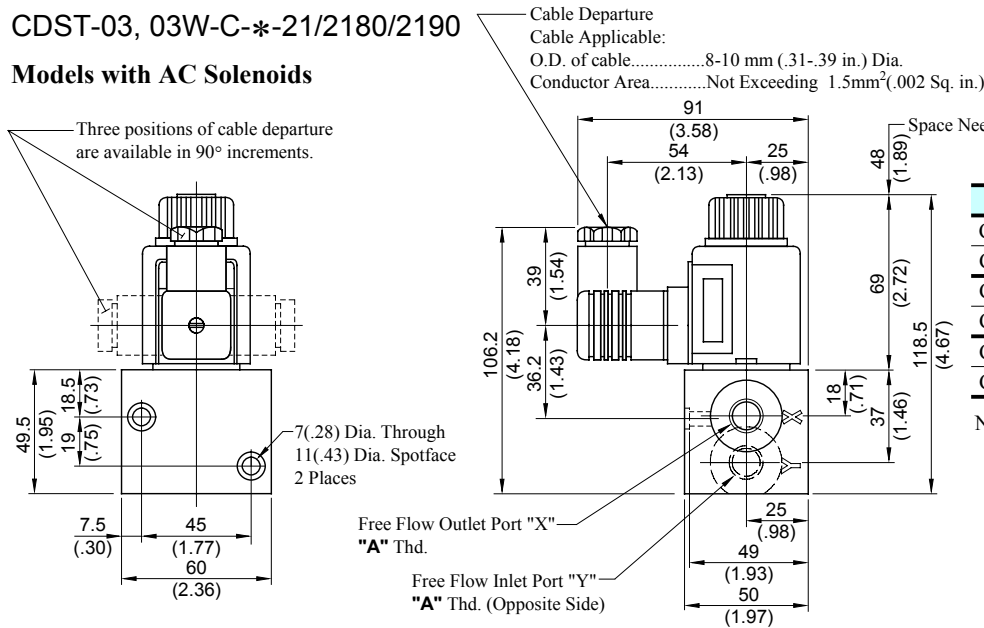

Model Numbers	"A" Thd.
CDST-03W-C-*21	Rc 1/4
CDST-03-C-*21	Rc 3/8
CDST-03W-C-*2180	1/4 BSP.F
CDST-03-C-*2180	3/8 BSP.F
CDST-03W-C-*2190	1/4 NPT
CDST-03-C-*2190	3/8 NPT

Note: The position of cable departure can be changed. For the detail, refer to CDSC-03 on the previous page.

Models with DC Solenoids

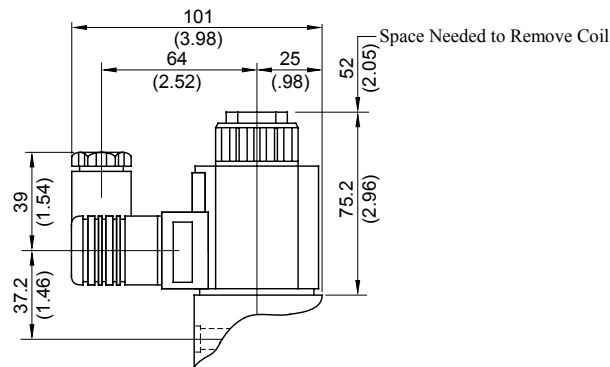

Models with R Type Solenoids

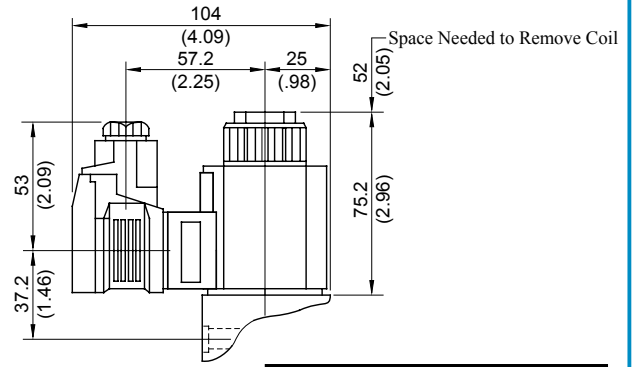

For other dimensions, refer to the "Models with AC Solenoids".

DIMENSIONS IN MILLIMETRES (INCHES)

CDSG-03-C-*21/2190

Models with AC Solenoids

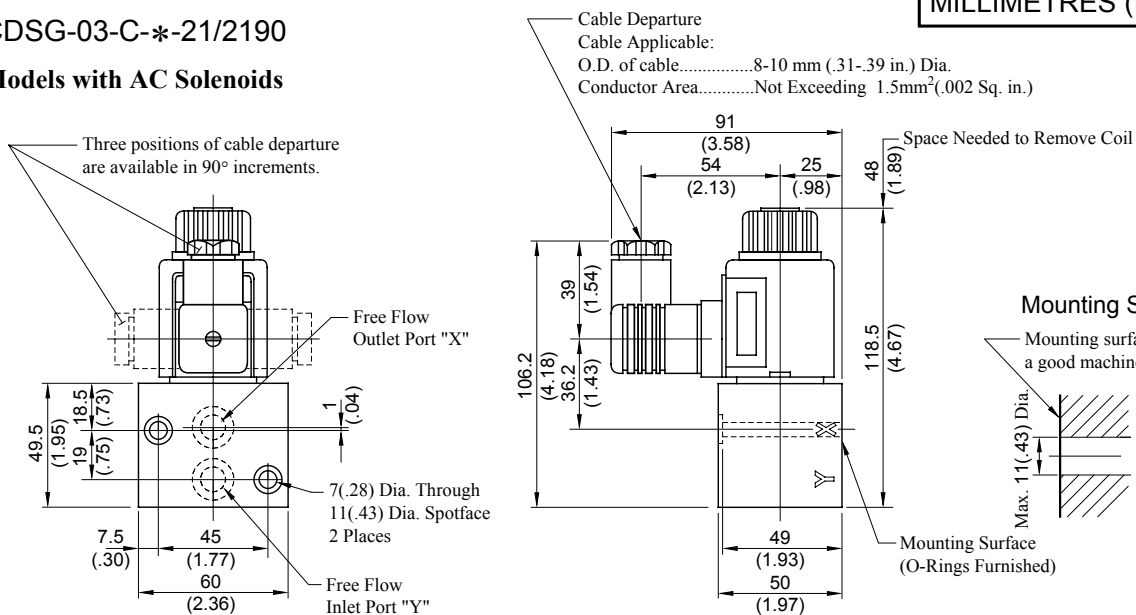

Note 1: For models with DC solenoids and models with R type solenoids, refer to CDST-03, 03W.

Note 2: The position of cable departure can be changed. For the detail, refer to CDSC-03 on the previous page.

Spare Parts List

CDST-03*-C-*-21/2180/2190
 CDSC-03-C-*-21/2190
 CDSG-03-C-*-21/2190

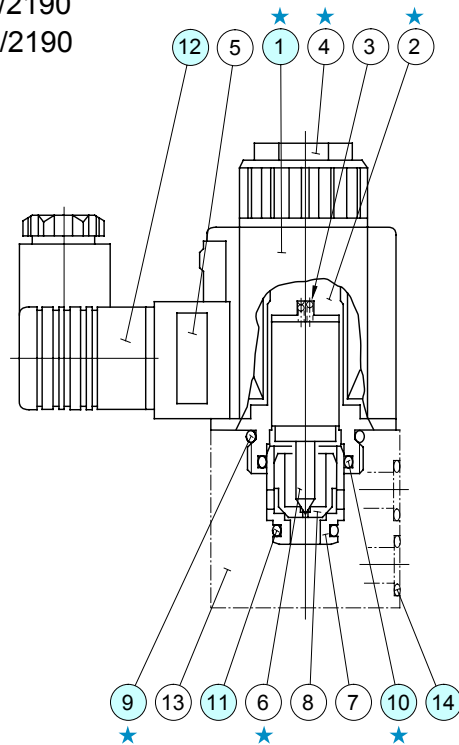

Solenoid assembly is composed of the parts marked with ★.

⚠ CAUTION

When making replacement of seals or solenoid assemblies, please do it carefully after reading through the relevant instructions in the Operator's Manual.

● Solenoid Ass'y, Coil Ass'y and Connector Ass'y No.

Valve Model No.	Solenoid Ass'y No.	① Coil No.	⑫ Connector Ass'y No.
CDS*-03*-C-A100	CSA1-100-20	C-CSA1-100-20	GDM-211-B-11
CDS*-03*-C-A120	CSA1-120-20	C-CSA1-120-20	
CDS*-03*-C-A200	CSA1-200-20	C-CSA1-200-20	
CDS*-03*-C-A240	CSA1-240-20	C-CSA1-240-20	
CDS*-03*-C-D12	CSD1-12-20	C-SD1-12-50	GDM-211-B-11
CDS*-03*-C-D24	CSD1-24-20	C-SD1-24-50	
CDS*-03*-C-D48	CSD1-48-20	C-SD1-48-50	
CDS*-03*-C-R100	CSR1-100-20	C-SR1-100-50	GDME-211-R-B-10
CDS*-03*-C-R200	CSR1-200-20	C-SR1-200-50	

● List of Seals

Item	Name of Parts	Part Numbers	Qty.	Remarks
9	O-Ring	SO-NB-P26	1	_____
10	O-Ring	SO-NB-P20	1	_____
11	O-Ring	SO-NB-P12	1	_____
14	O-Ring	SO-NB-A014	2	only for CDSG

Note: When ordering the seals, please specify the seal kit number from the table right.

● List of Seal Kits

Valve Model Numbers	Seal Kit Numbers
CDSC-03-C-*-21*	KS-CDSC-03-20
CDST-03*-C-*-21*	
CDSG-03-C-*-21*	KS-CDSG-03-20

● Change of supply voltage

The supply voltage can be changed by replacing the coil.

⚠ WARNING

Before maintenance or removal, do the following. Failure to do these may cause components to move, causing oil leakage or serious accidents.

- Shut off the equipment's power supply, and be sure that all electric motors and engines have stopped.
- Return pressure in all hydraulic systems to zero.

Interchangeability

■ Interchangeability between Old and New Design

Because of solenoid assembly improvements, CDS*-03* has been model-changed (design 20 to design 21).

● Specifications and Characteristics

There are no changes in the specifications and characteristics of the valves themselves.

● Solenoid Ratings

There are changes in the inrush current, holding current and power as shown below. No other changes.

Electric Source	Coil Type	Frequency (Hz)	Voltage (V)		Current & Power at Rated Voltage					
			Source Rating	Serviceable Range	Inrush (A)		Holding (A)		Power (W)	
					New	Old	New	Old	New	Old
AC	A100	50	100	80 - 110	1.12	1.30	0.55	0.52	—	—
			100	90 - 120	0.95	1.08	0.40	0.39		
		110	0.86		1.19	0.36	0.47			
	A120	50	120		96 - 132	0.93	1.08	0.46		
			120	108 - 144	0.79	0.98	0.33	0.33		
	A200	50	200	160 - 220	0.56	0.65	0.28	0.27		
			200	180 - 240	0.48	0.54	0.20	0.20		
		60	220		0.43	0.59	0.18	0.24		
			220	0.43	0.59	0.18	0.24			
	A240	50	240	192 - 264	0.47	0.55	0.23	0.23		
60		216 - 288		0.40	0.45	0.17	0.17			
DC (K Series)	D12	—	12	10.8 - 13.2	—	—	2.20	2.40	26	29
	D24		24	21.6 - 26.4			1.10	1.20		
	D48		48	43.2 - 52.8			0.55	0.60		
AC→DC Rectified	R100	50/60	100	90 - 110	—	—	0.30	0.32	26	29
	R200		200	180 - 220			0.15	0.17		

● Interchangeability in Installation

● AC Solenoids

Most items of mounting are interchangeable except the dimensions as shown below. In addition, the size of the spanner (core end faces) for locking the CDSC cartridges has been changed to 15-19 mm across flats.

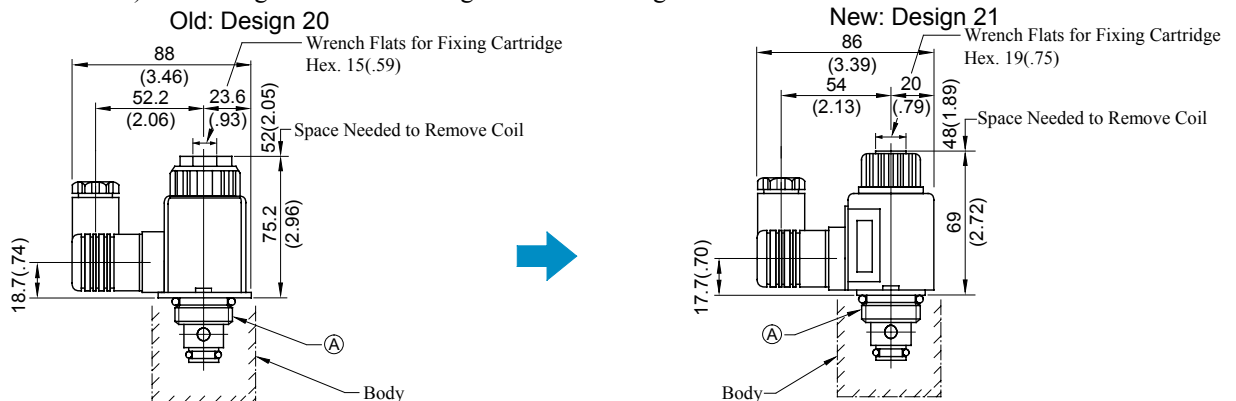

● DC/R Type Solenoids

Most items of mounting are interchangeable except the dimensions as shown below. The solenoid shape changed from circular to hexagonal. No change in the size 15 mm of the spanner for locking cartridges.

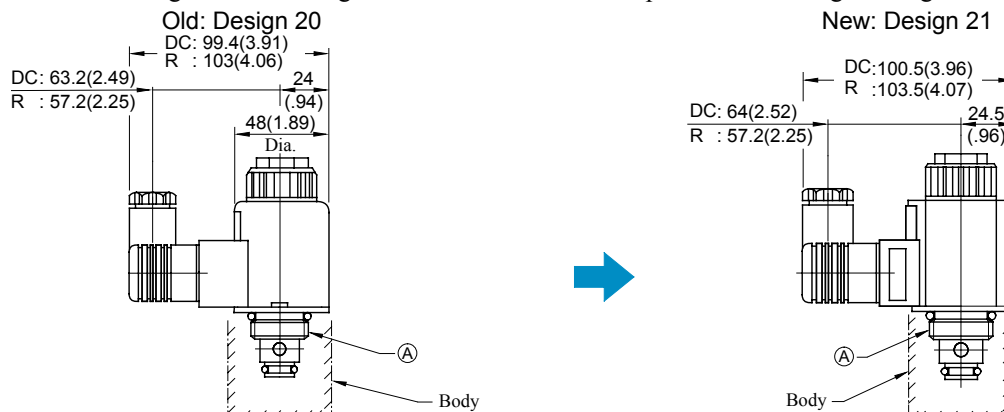

Note: The above drawings give illustrations for the cartridge type. The dimension (A) at the mounting section remains unchanged. In case of the Thread Connection Type and Gasket Mounting Type, a body is mounted to the hatched section. The dimensions of the body remain unchanged.