



**POPPET TYPE
SOLENOID OPERATED DIRECTIONAL VALVES**
DSLГ-01-3-C/O
DSLГ-01-4-O
Sub-plate Mounting

**DIRECTIONAL
CONTROLS**

Up to 31.5 MPa (4570 PSI), 16 L/min (4.2 U.S.GPM)

These are Solenoid Operated Directional Valves of No Leak Type developed with the aim of responding the demand of the age including energy saving. Because these valves are of no leak type they allow the low viscosity hydraulic fluids to be used as well as the circuit construction which cannot be used by the conventional spool type directional valves because of too much internal leak of pressure oil. The use of the low viscosity hydraulic fluids reduces the pressure loss which can arise from the passage resistance of the hydraulic fluids, leading to the system energy saving.

● **High Response High Reliability**

Because these valves are of poppet type, there is no overlap, high response can be achieved. At the same time, hydraulic lock is eliminated.

● **No Leak**

Sheet type seal has been adopted and internal leak is greatly reduced.

● **ISO Comformant Mounting Surface**

Because the mounting surface conforms to ISO 4401-AB-03-4-A, there is an interchangeability with the conventional valves. This makes it possible to use these valves in combination with 01 Series Modular Valves.

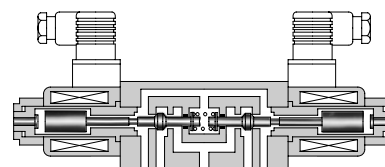

■ **Specifications**

Model Numbers	Max. Flow L/min (U.S. GPM)	Max. Operating Pressure MPa (PSI)	Max. T-Line Back Pressure MPa (PSI)	Max. Changeover Frequency min ⁻¹ {Cycles/Min}	Internal leakage cm ³ /min (cu. in./min)	Approx. Mass kg (lbs.)	Graphic Symbols
DSLГ-01-3-C-*N-10*	16 (4.2)	31.5 (4570)	16 (2320)	240	Less than *1 0.5 (.03)	1.9 (4.2)	
DSLГ-01-3-O-*N-10*					Less than *2 1 (.06)		
DSLГ-01-4-O-*N-10*							

★ 1. This is the leakage towards "T" port in A port block at "P" port pressure 14 MPa (2030 PSI).

★ 2. This is the leakage towards "T" port in A•B port block at "P" port pressure 14 MPa (2030 PSI).

■ **Solenoid Ratings**

Electric Source	Coil Type	Frequency (Hz)	Voltage (V)		Current & Power at Rated Voltage	
			Source Rating	Serviceable Range	Holding (A)	Power (W)
DC (K Series)	D12	—	12	10.8 - 13.2	2.2	26
	D24	—	24	21.6 - 26.4	1.1	
AC→DC Rectified	R100	50/60	100	90 - 110	0.3	26
	R200	50/60	200	180 - 220	0.15	

■ Hydraulic Fluids

● Fluid Types

Any type of hydraulic fluids listed in the table below can be used.

Petroleum base oils	Use fluids equivalent to ISO VG 32 or VG 46.
Synthetic fluids	Use phosphate ester or polyol ester fluid. When phosphate ester fluid is used, prefix "F-" to the model number because the special seals (fluororubber) are required to be used.
Water containing fluids	Use water-glycol fluid.

Note: For use with hydraulic fluids other than those listed above, please consult your Yuken representatives in advance.

● Recommended Viscosity and Oil Temperatures

Viscosity ranging between 15 - 400 mm²/s (77 - 1800 SSU).

Oil temperatures between -15/+70°C (5 - 158°F).

Use hydraulic fluids which satisfy the recommended viscosity and oil temperatures given above.

● Control of Contamination

Due caution must be paid to maintaining control over contamination of the hydraulic fluids which may otherwise lead to breakdowns and shorten the life of the valves. Please maintain the degree of contamination within NAS 1638-Grade 12. Use 25 μm or finer line filter.

■ Model Number Designation

F-	DSLГ	-01	-4	-O	-D24	-N	-10	*
Special Seals	Series Number	Valve Size	Number of Port	Function	Coil Type	Type of Electrical Conduit Connection	Design Number	Design Standards
F: Special Seals for Phosphate Ester Type Fluids (Omit if not required)	DSLГ: Poppet Type Solenoid Operated Directional Valve (Sub-plate Mtg.)	01	3: 3 Port 4: 4 Port	O: Normally Open C: Normally Closed O: Normally Open	DC D12, D24 AC→DC R100 R200	N: Plug-in Connector	10	Refer to ★

★ Design Standards: None Japanese Standard "JIS" and European Design Standard 90 N. American Design Standard

■ Sub-plate

Piping Size	Japanese Standard "JIS"		European Design Std.		N. American Design Std.		Approx. Mass kg (lbs.)
	Sub-plate Model No.	Thread Size	Sub-plate Model No.	Thread Size	Sub-plate Model No.	Thread Size	
1/8	DSGM-01-30	Rc 1/8	DSGM-01-3080	1/8 BSP.F	DSGM-01-3090	1/8 NPT	0.8 (1.8)
1/4	DSGM-01X-30	Rc 1/4	DSGM-01X-3080	1/4 BSP.F	DSGM-01X-3090	1/4 NPT	0.8 (1.8)
3/8	DSGM-01Y-30	Rc 3/8	—	—	DSGM-01Y-3090	3/8 NPT	0.8 (1.8)

● Sub-plates are available. Specify the sub-plate model number from the table above. When sub-plates are not used, the mounting surface should have a good machined finish.

■ Mounting Bolts

Four socket head cap screws in the table below are included.

Descriptions	Socket Head Cap Screw (4 pcs.)	Tightening Torque
Japanese Standard "JIS" European Design Standard	M5 × 45 Lg.	5-7 Nm (44-62 in. lbs.) [Applicable to working pressure more than 25 MPa (3630 PSI) : 6-7 Nm (53-62 in. lbs.)]
N. American Design Standard	No. 10-24 UNC × 1-3/4 Lg.	

Performance Characteristics

Pressure Drop

Hydraulic Fluid: Viscosity 35 mm²/s (164 SSU), Specific Gravity 0.850

4 Port Valve

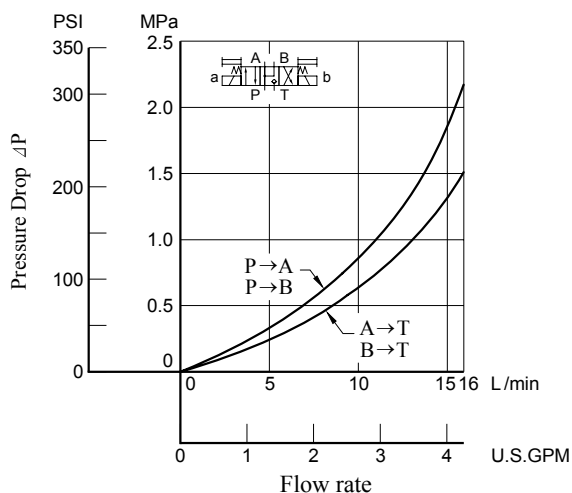

3 Port Valve

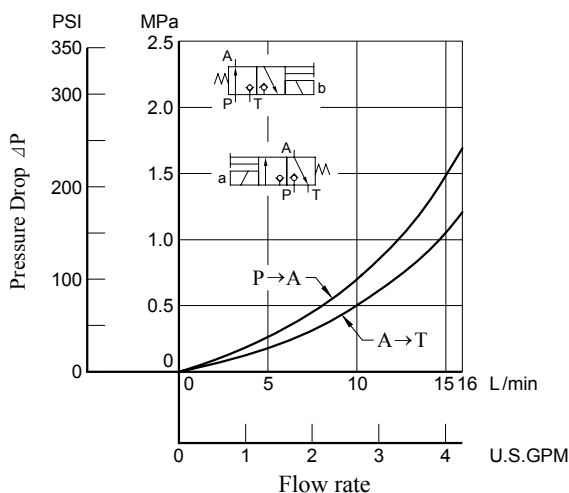

- For any other viscosity, multiply the factors in the table below.

Viscosity	mm ² /s	15	20	30	40	50	60	70	80	90	100
	SSU	77	98	141	186	232	278	324	371	417	464
Factor		0.81	0.87	0.96	1.03	1.09	1.14	1.19	1.23	1.27	1.30

- For any other specific gravity (G'), the pressure drop (ΔP') may be obtained from the formula below.

$$\Delta P' = \Delta P (G'/0.850)$$

Changeover Time

Changeover time varies according to hydraulic circuit of the model actually used and conditions. An example of measurement is given in the figure below.

Test Circuit and Conditions

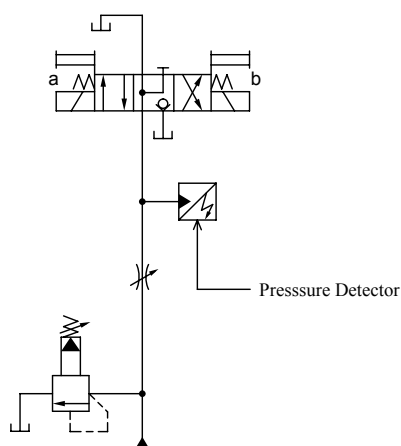

Pressure: 21 MPa (3050 PSI)
Flow Rate: 16 L/min (4.2 U.S.GPM)
Voltage: Rated voltage

Result of Measurement

(DC Solenoid)

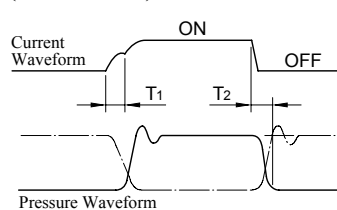

(AC→DC Rectified)

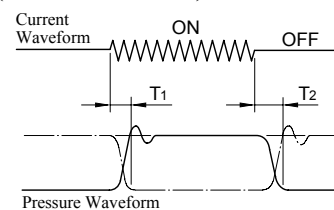

Note: Alternate long and short dash lines in the pressure waveform figures indicate the waveforms for Normally Closed Type 3 Port Valves.

Solenoid Type	Model Numbers	Time (ms)		Remarks
		T1	T2	
DC	DSLGL-01-4-O-D*	55	30	4 port valve, normally open
	DSLGL-01-3-O-D*	55	30	3 port valve, normally open
	DSLGL-01-3-C-D*	70	25	3 port valve, normally closed
AC→DC Rectified	DSLGL-01-4-O-R*	55	150	4 port valve, normally open
	DSLGL-01-3-O-R*	55	150	3 port valve, normally open
	DSLGL-01-3-C-R*	70	150	3 port valve, normally closed

4 Port Valve

Mounting Surface:
ISO 4401-AB-03-4-A

● Normally Open: DSLG-01-4-O-*-N-10/1090

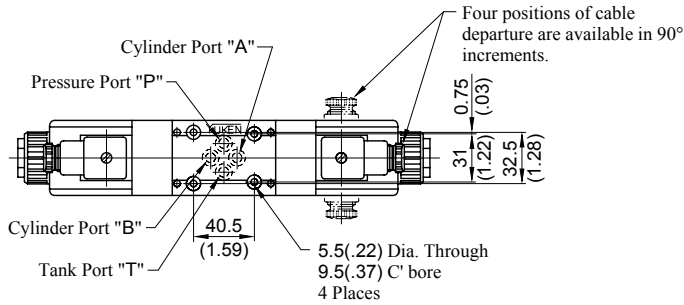

**DIMENSIONS IN
MILLIMETRES (INCHES)**

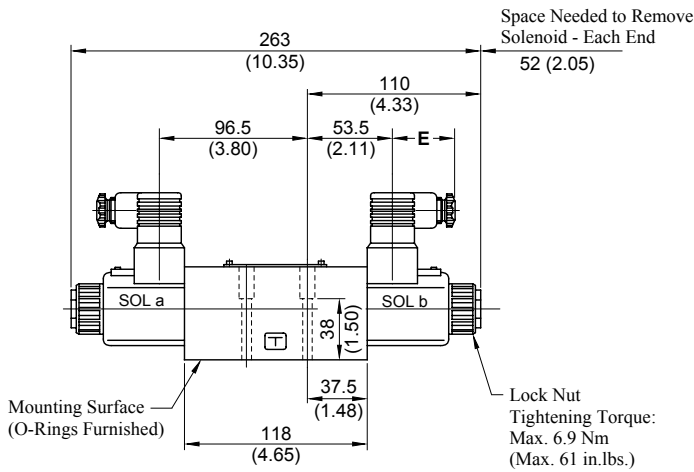

The connector can be moved to various positions by loosening the "Lock Nut". After location tighten "Lock Nut".

Cable Departure Cable Applicable:
Outside Dia. 8-10 mm (.31 - .39 in.)
Conductor Area ... Not Exceeding 1.5 mm² (.002 Sq. in.)

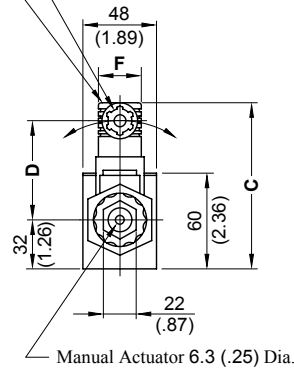

Model Numbers	Dimensions mm (Inches)			
	C	D	E	F
DSL-G-01-4-O-D*-N	108 (4.25)	64 (2.52)	39 (1.54)	27.5 (1.08)
DSL-G-01-4-O-R*-N	111 (4.37)	57.2 (2.25)	53 (2.09)	34 (1.34)

● The information on 3 Port Valves is provided in the following page.

Mounting Surface:
ISO 4401-AB-03-4-A

3 Port Valves

DIMENSIONS IN
MILLIMETRES (INCHES)

● Normally Open Type: DSL_G-01-3-O-*₋N-10/1090

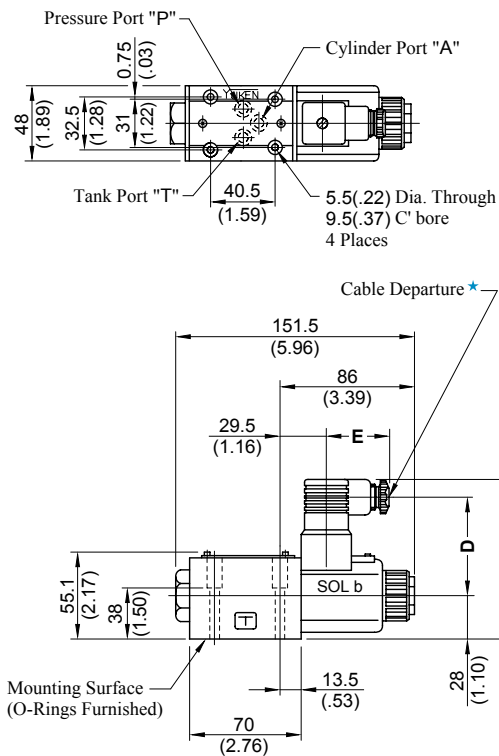

● Normally Closed Type: DSL_G-01-3-C-*₋N-10/1090

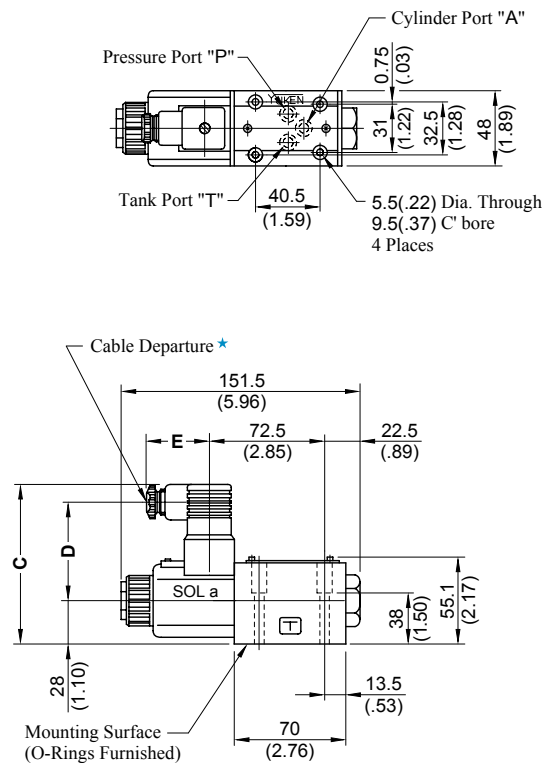

★ Cable departure position can be changed. See "4 Port Valves" in the previous page for the details.

Model Numbers	Dimensions mm (Inches)		
	C	D	E
DSL _G -01-3-* ₋ D*-N	104 (4.09)	64 (2.52)	39 (1.54)
DSL _G -01-3-* ₋ R*-N	107 (4.21)	57.2 (2.25)	53 (2.09)

■ Sub-plate

DSGM-01*-30/3080/3090

DIMENSIONS IN
MILLIMETRES (INCHES)

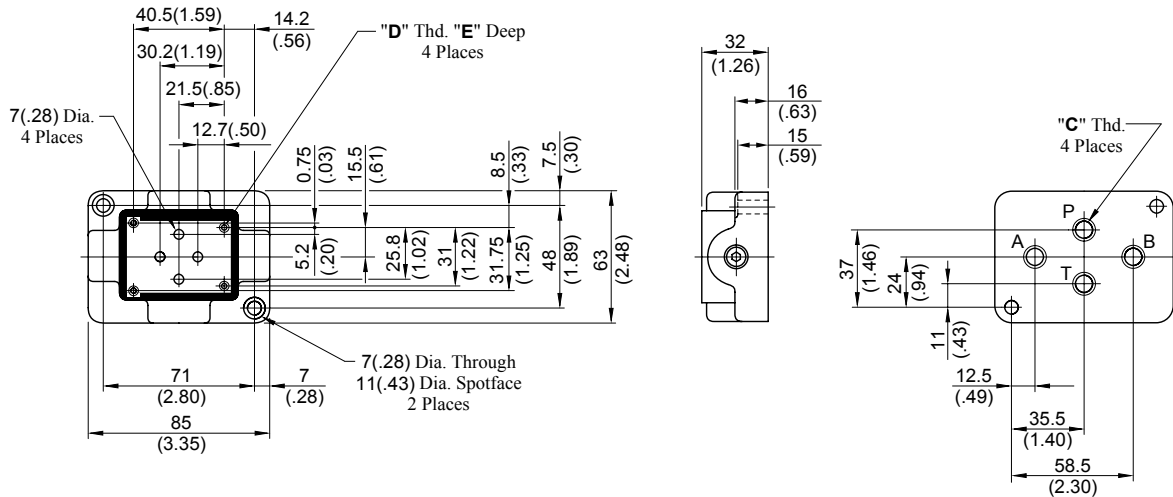

Sub-plate Model Numbers	Thread Size		"E" mm (in.)
	"C" Thd.	"D" Thd.	
DSGM-01-30	Rc 1/8	M5	10 (.39)
DSGM-01-3080	1/8 BSP.F		
DSGM-01-3090	1/8 NPT	No.10-24 UNC	12 (.47)
DSGM-01X-30	Rc 1/4	M5	10 (.39)
DSGM-01X-3080	1/4 BSP.F		
DSGM-01X-3090	1/4 NPT	No.10-24 UNC	12 (.47)
DSGM-01Y-30	Rc 3/8	M5	10 (.39)
DSGM-01Y-3090	3/8 NPT	No.10-24 UNC	12 (.47)

■ Instructions

● **Mounting**

No mounting restrictions for any models.

● **Solenoid Shifting**

On double solenoid valves do not energise both at the same time.

● **Valve Tank Port**

Avoid connecting the valve tank port to a line with possible surge pressure.

● **Operating Force by Manual Actuator**

Take care as the operating force by the manual actuator increases in proportion to the tank line back pressure.

(See the graph right.)

Operating Force by Manual Actuator

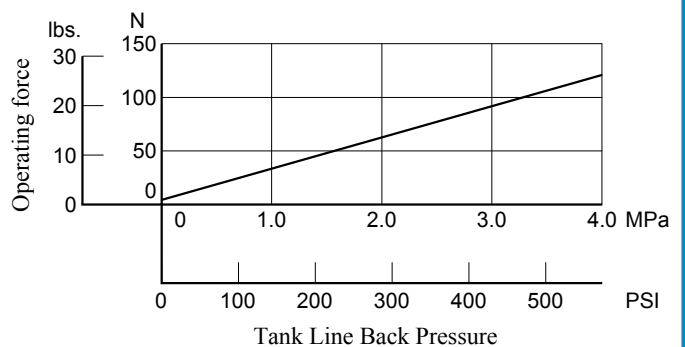

Spare Parts List

4 Port Valve

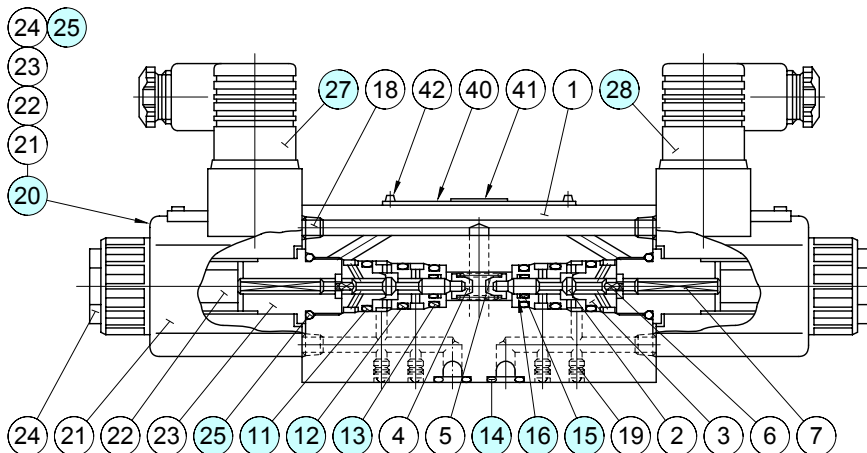

3 Port Valve

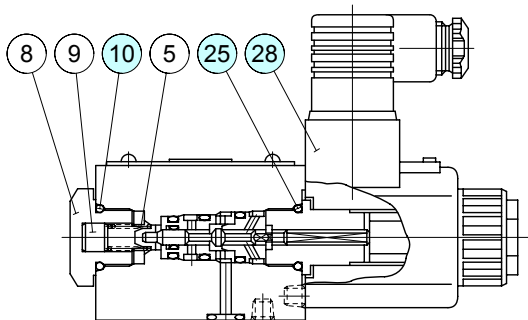

⚠ CAUTION

When making replacement of seals or solenoid assemblies, do it carefully after reading through the relevant instructions in the Operator's Manual.

● List of Seals

Item	Name of Parts	Part Numbers	Quantity	
			4 Port Valve	3 Port Valve
10	O-Ring	SO-NB-P18	—	1
11	O-Ring	SO-NB-P14	2	1
12	O-Ring	SO-NB-P12	2	1
13	O-Ring	SO-NB-P11	2	1
14	O-Ring	SO-NB-P9	4	3
15	O-Ring	SO-NA-P5	2	1
16	Back Up Ring	2705-VK414322-8	2	1
25	O-Ring	SO-NB-P18	2	1

Note 1: O-Ring of item ②⑤ are included in solenoid assembly.

2: When ordering the seals, specify the seal kit number from the table right.

● Change of supply voltage

The supply voltage can be changed by replacing the coil ②① only.

● List of Seal Kits

Valve Model Numbers	Seal Kit Numbers
DSLGL-01-3-O-*-N-10*	KS-DSLGL-01-3-N-10
DSLGL-01-3-C-*-N-10*	
DSLGL-01-4-O-*-N-10*	KS-DSLGL-01-4-N-10

● List of Solenoid Ass'y and Connectors

Valve Model No.	②① Solenoid Ass'y No.	②① Coil No.	②⑦ Connector No.	②⑧ Connector No.
DSLGL-01-*-D12-N-10*	SD1L-12-N-11	C-SD1-12-N-50	GDM-211-A-11	GDM-211-B-11
DSLGL-01-*-D24-N-10*	SD1L-24-N-11	C-SD1-24-N-50		
DSLGL-01-*-R100-N-10*	SD1L-100-N-11	C-SR1-100-N-50	GDME-211-R-A-10	GDME-211-R-B-10
DSLGL-01-*-R200-N-10*	SD1L-200-N-11	C-SR1-200-N-50		