



RESTRICTORS
SRT/SRG-03/06/10 (3/8, 3/4, 1-1/4)
ONE WAY RESTRICTORS
SRCT/SRCG-03/06/10 (3/8, 3/4, 1-1/4)
Threaded Connections / Sub-plate Mounting

**FLOW
CONTROLS**

Up to 25 MPa (3630 PSI), 500 L/min (132 U.S.GPM)

This valve is used to regulate an actuator speed in a circuit where line pressure is almost steady and small fluctuation of oil flow due to pressure changes is permitted. Integrated check valve allows reversed free flow from outlet to inlet port. Pressure balanced construction provides less effort in adjustment at high pressure.

■ Restrictors

■ One Way Restrictors

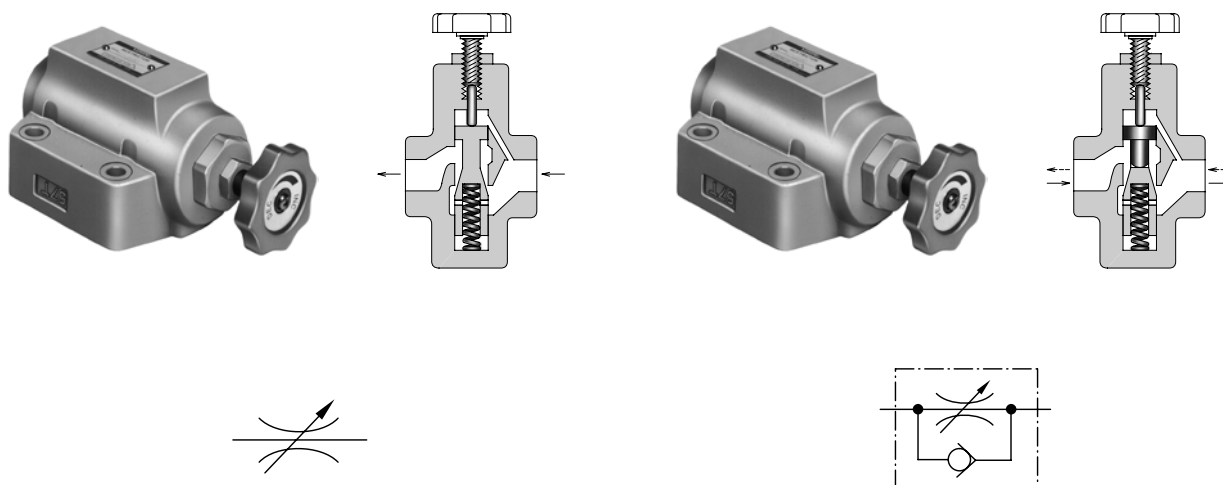

■ Hydraulic Fluids

● Fluid Types

Any type of hydraulic fluid listed in the table below can be used.

Petroleum base oils	Use fluids equivalent to ISO VG 32 or VG 46.
Synthetic fluids	Use phosphate ester or polyol ester fluid. When phosphate ester fluid is used, prefix "F-" to the model number because the special seals (fluororubber) are required to be used.
Water containing fluids	Use water-glycol fluid.

Note: For use with hydraulic fluids other than those listed above, please consult your Yuken representatives in advance.

● Recommended Viscosity and Temperatures

Viscosity ranging between 15 - 400 mm²/s (77 - 1800 SSU).

Oil temperatures between -15/+70°C (5 - 158°F).

Use hydraulic fluids which satisfy the recommended viscosity and oil temperatures given above.

● Control of Contamination

Due caution must be paid to maintaining control over contamination of the hydraulic fluids which may otherwise lead to breakdowns and shorten the life of the valves. Please maintain the degree of contamination within NAS 1638-Grade 12. Use 25 μm or finer line filter.



Specifications

Valve Name	Model Numbers		Rated Flow* L/min (U.S.GPM)	Max. Operating Pres. MPa (PSI)	Approx. Mass kg (lbs.)	
	Threaded Connection	Sub-plate Mounting			Threaded Connection	Sub-plate Mounting
Restrictor	SRT-03-50/5080/5090	SRG-03-50/5090	30 (7.9)	25 (3630)	1.5 (3.3)	2.5 (5.5)
	SRT-06-50/5080/5090	SRG-06-50/5090	85 (22.4)		3.8 (8.4)	3.9 (8.6)
	SRT-10-50/5080/5090	SRG-10-50/5090	230 (60.7)		9.1 (20.1)	7.5 (16.5)
One Way Restrictor	SRCT-03-50/5080/5090	SRCG-03-50/5090	30 (7.9)	25 (3630)	1.5 (3.3)	2.5 (5.5)
	SRCT-06-50/5080/5090	SRCG-06-50/5090	85 (22.4)		3.8 (8.4)	3.9 (8.6)
	SRCT-10-50/5080/5090	SRCG-10-50/5090	230 (60.7)		9.1 (20.1)	7.5 (16.5)

★ Rated flow stands for approximate flow rate when the pressure drop between inlet and outlet ports of the valve in fully opened condition becomes 0.3 MPa (44 PSI) maximum at fluid's specific gravity of 0.85 and kinematic viscosity of 20 mm²/s (98 SSU).

Yuken can offer flanged connection valves described below.

For details, contact us.

Model Numbers	Rated Flow L/min (U.S.GPM)	Max. Operating Pressure MPa (PSI)
SRF/SRCF-10-50 SRF/SRCF-10-5090	230 (60.7)	25 (3630)
SRF/SRCF-16-50 SRF/SRCF-16-5090	500 (132)	

Graphic Symbols

SRT / SRG



SRCT / SRCG

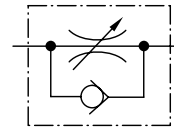

Model Number Designation

F-	SR	T	-03	-50	*		
Special Seals	Series Number	Type of Mounting	Valve Size	Design Number	Design Standards		
F: Special Seals for Phosphate Ester Type Fluids (Omit if not required)	SR: Restrictor	T: Threaded Connection	03	50	None: Japanese Std. "JIS" 80: European Design Std. 90: N.American Design Std.		
			06	50			
			10	50			
		G: Sub-plate Mounting	03	50		None: Japanese Std. "JIS" & European Design Std. 90: N.American Design Std.	
			06	50			
			10	50			
	SRCT: One Way Restrictor	T: Threaded Connection	T: Threaded Connection	03	50		None: Japanese Std. "JIS" 80: European Design Std. 90: N.American Design Std.
				06	50		
				10	50		
		G: Sub-plate Mounting	G: Sub-plate Mounting	03	50	None: Japanese Std. "JIS" & European Design Std. 90: N.American Design Std.	
				06	50		
				10	50		

■ Attachment

● Mounting Bolts

Valve Model Numbers	Socket Head Cap Screw		Qty.
	Japanese Std. "JIS" and European Design Std.	N. American Design Std.	
SRG/SRCG-03	M10 × 45 Lg.	3/8-16 UNC × 1-3/4 Lg.	4
SRG/SRCG-06	M10 × 50 Lg.	3/8-16 UNC × 2 Lg.	4
SRG/SRCG-10	M10 × 55 Lg.	3/8-16 UNC × 2-1/4 Lg.	6

■ Sub-plate

Valve Model Numbers	Japanese Standard "JIS"		European Design Standard		N. American Design Standard		Approx. Mass kg (lbs.)
	Sub-plate Model Numbers	Thread Size	Sub-plate Model Numbers	Thread Size	Sub-plate Model Numbers	Thread Size	
SRG SRCG -03	CRGM-03-50	Rc 3/8	CRGM-03-5080	3/8 BSP.F	CRGM-03-5090	3/8 NPT	1.6 (3.5)
	CRGM-03X-50	Rc 1/2	CRGM-03X-5080	1/2 BSP.F	CRGM-03X-5090	1/2 NPT	1.6 (3.5)
SRG SRCG -06	CRGM-06-50	Rc 3/4	CRGM-06-5080	3/4 BSP.F	CRGM-06-5090	3/4 NPT	2.4 (5.3)
	CRGM-06X-50	Rc 1	CRGM-06X-5080	1 BSP.F	CRGM-06X-5090	1 NPT	3.0 (6.6)
SRG SRCG -10	CRGM-10-50	Rc 1-1/4	CRGM-10-5080	1-1/4 BSP.F	CRGM-10-5090	1-1/4 NPT	4.8 (10.6)
	CRGM-10X-50	Rc 1-1/2	CRGM-10X-5080	1-1/2 BSP.F	CRGM-10X-5090	1-1/2 NPT	5.7 (12.6)

- Sub-plates are available. Specify the sub-plate model number from the table above. When sub-plates are not used, the mounting surface should have a good machined finish.

■ Instructions

● Flow Adjustment

Slacken the lock nut and turn the flow adjustment knob anti-clockwise to throttle flow. After achieving satisfactory performance tighten the lock nut.



SRT/SRCT-03-50/5080/5090
SRT/SRCT-06-50/5080/5090
SRT/SRCT-10-50/5080/5090

DIMENSIONS IN
MILLIMETRES (INCHES)

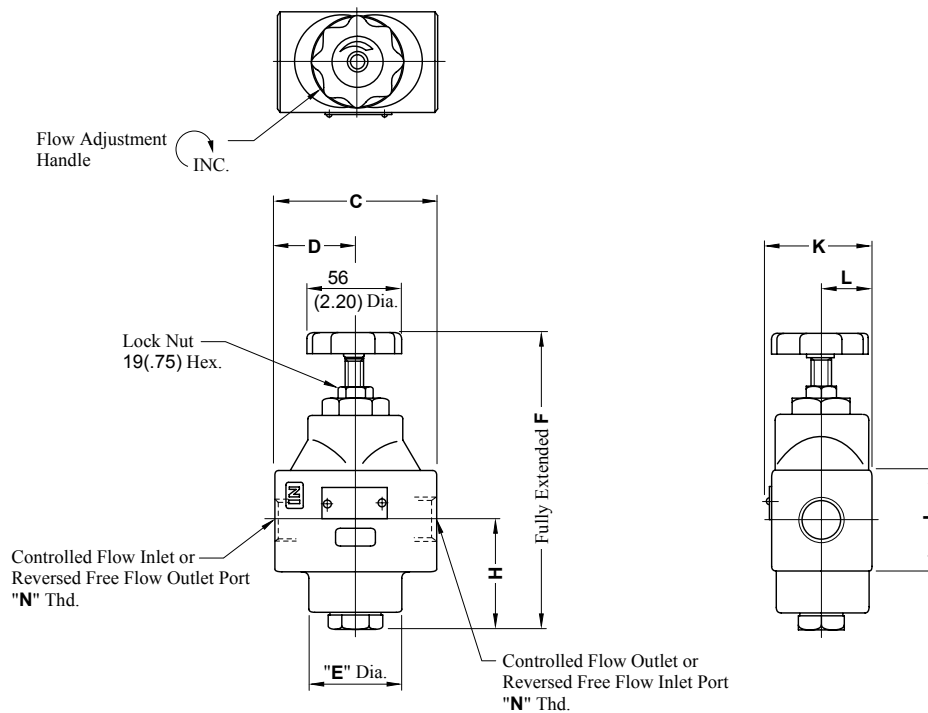

Model Numbers	Dimensions mm (Inches)								
	C	D	E	F	H	J	K	L	"N" Thd.
SRT/SRCT-03-50									Rc 3/8
SRT/SRCT-03-5080	72 (2.83)	36 (1.42)	44 (1.73)	150.5 (5.93)	53.5 (2.11)	38 (1.50) Dia.	46 (1.81)	22 (.87)	3/8 BSP.F
SRT/SRCT-03-5090									3/8 NPT
SRT/SRCT-06-50									Rc 3/4
SRT/SRCT-06-5080	100 (3.94)	50 (1.97)	58 (2.28)	180 (7.09)	66.5 (2.62)	62 (2.44) Sq.	64 (2.52)	31 (1.22)	3/4 BSP.F
SRT/SRCT-06-5090									3/4 NPT
SRT/SRCT-10-50									Rc 1-1/4
SRT/SRCT-10-5080	138 (5.43)	69 (2.72)	80 (3.15)	227 (8.94)	86 (3.39)	80 (3.15) Sq.	82 (3.23)	40 (1.57)	1-1/4 BSP.F
SRT/SRCT-10-5090									1-1/4 NPT

SRG/SRCG-03-50/5090

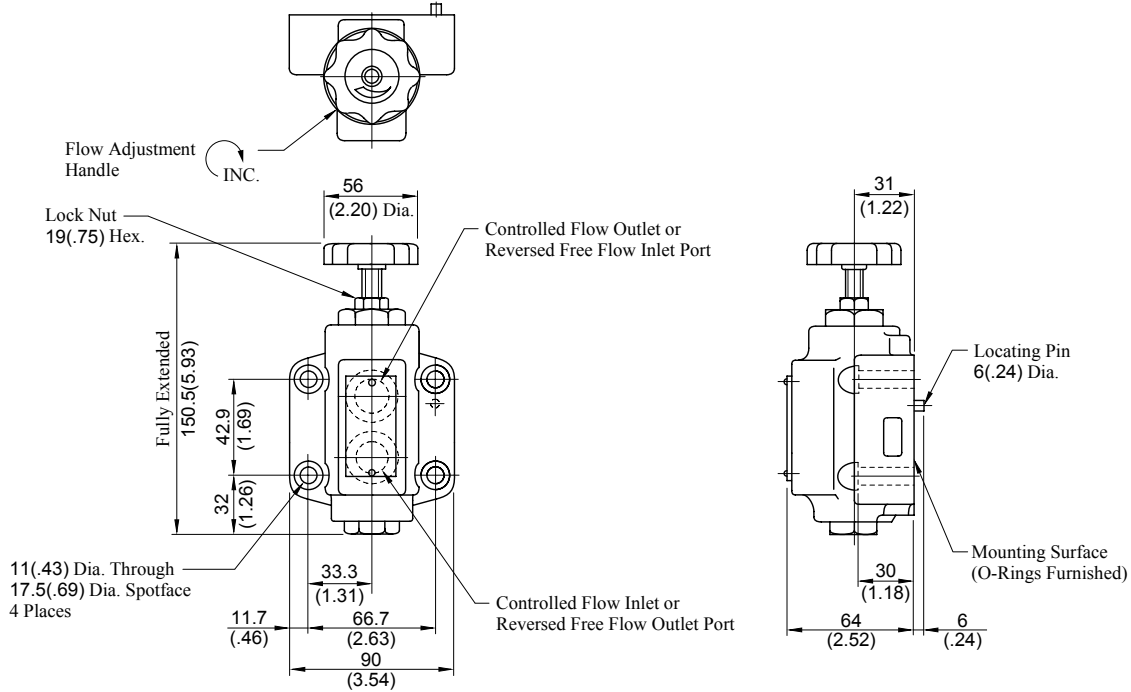

DIMENSIONS IN
MILLIMETRES (INCHES)

Sub-plate

CRGM-03
03X-50/5080/5090

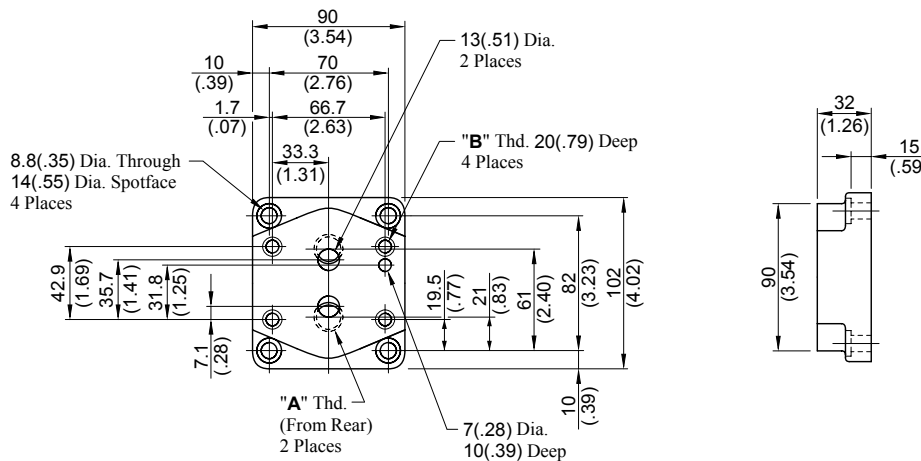

Sub-plate Model Numbers	"A" Thd.	"B" Thd.
CRGM-03-50	Rc 3/8	M10
CRGM-03-5080	3/8 BSP.F	
CRGM-03-5090	3/8 NPT	
CRGM-03X-50	Rc 1/2	M10
CRGM-03X-5080	1/2 BSP.F	
CRGM-03X-5090	1/2 NPT	

SRG/SRCG-06-50/5090

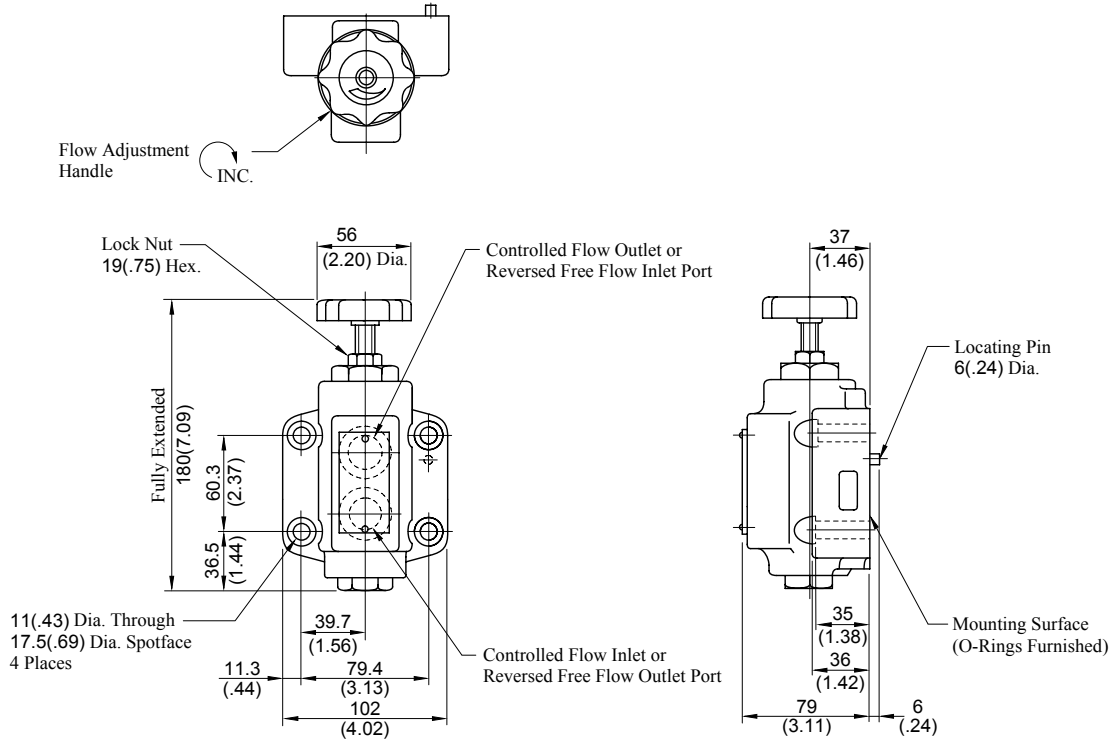

**DIMENSIONS IN
MILLIMETRES (INCHES)**

Sub-plate

CRGM-06-50/5080/5090 06X

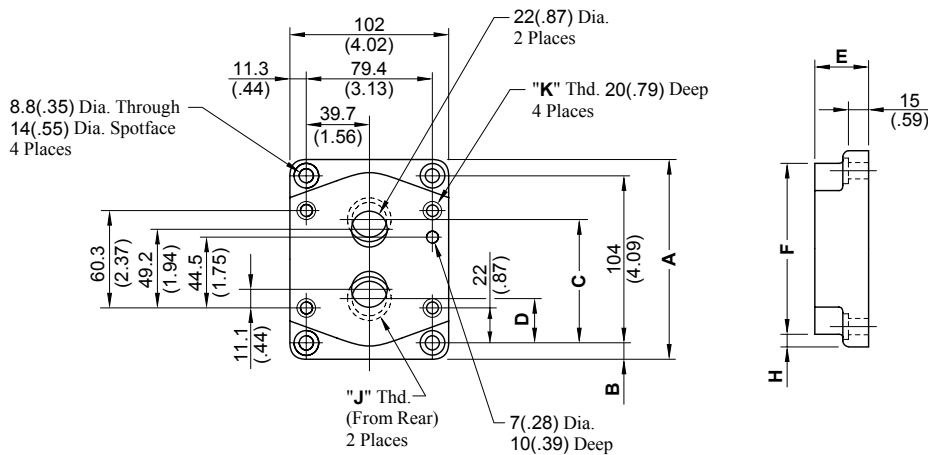

Sub-plate Model Numbers	Dimensions mm (Inches)							"J" Thd.	"K" Thd.
	A	B	C	D	E	F	H		
CRGM-06-50	124 (4.88)	10 (.39)	77 (3.03)	27 (1.06)	36 (1.42)	110 (4.33)	7 (.28)	Rc 3/4	M10
CRGM-06-5080								3/4 BSP.F	
CRGM-06-5090								3/4 NPT	
CRGM-06X-50	136 (5.35)	16 (.63)	82.3 (3.24)	22 (.87)	45 (1.77)	136 (5.35)	0	Rc 1	M10
CRGM-06X-5080			80 (3.15)	24 (.94)				1 BSP.F	
CRGM-06X-5090			82.3 (3.24)	22 (.87)				1 NPT	

SRG/SRCG-10-50/5090

Mounting surface: ISO 5781-AJ-10-2-A

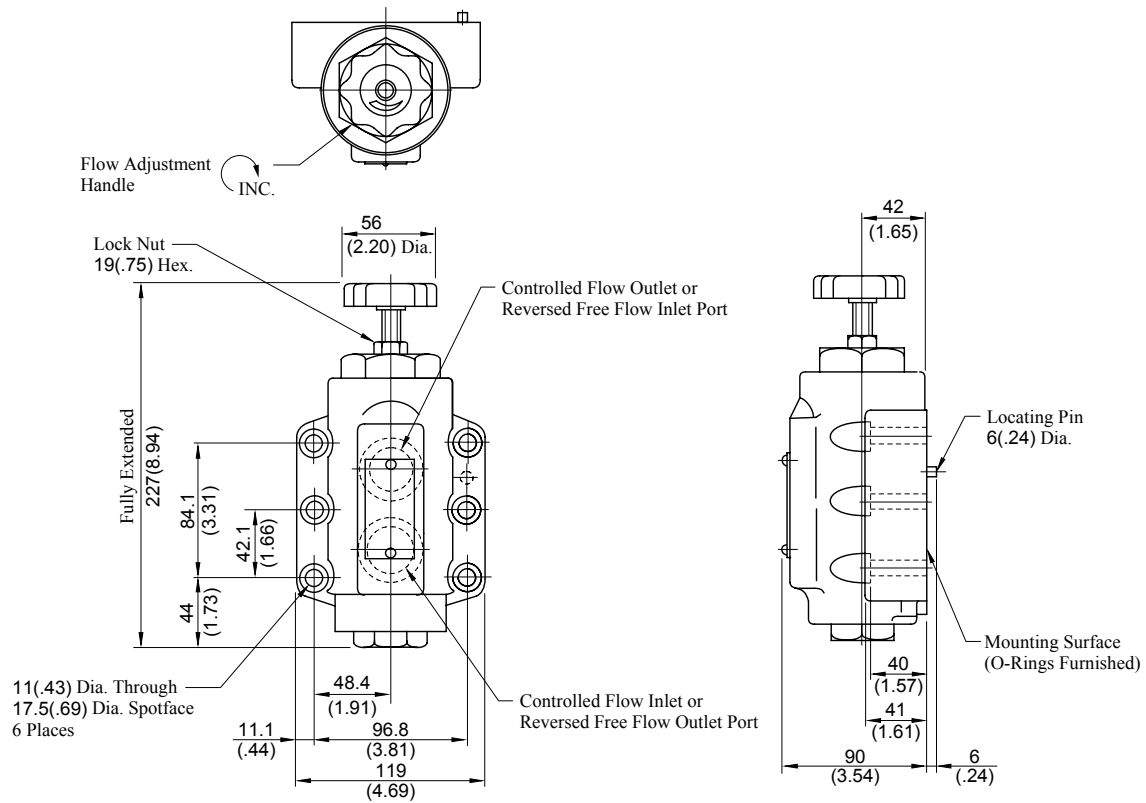

DIMENSIONS IN MILLIMETRES (INCHES)

Sub-plate

CRGM-10-50/5080/5090

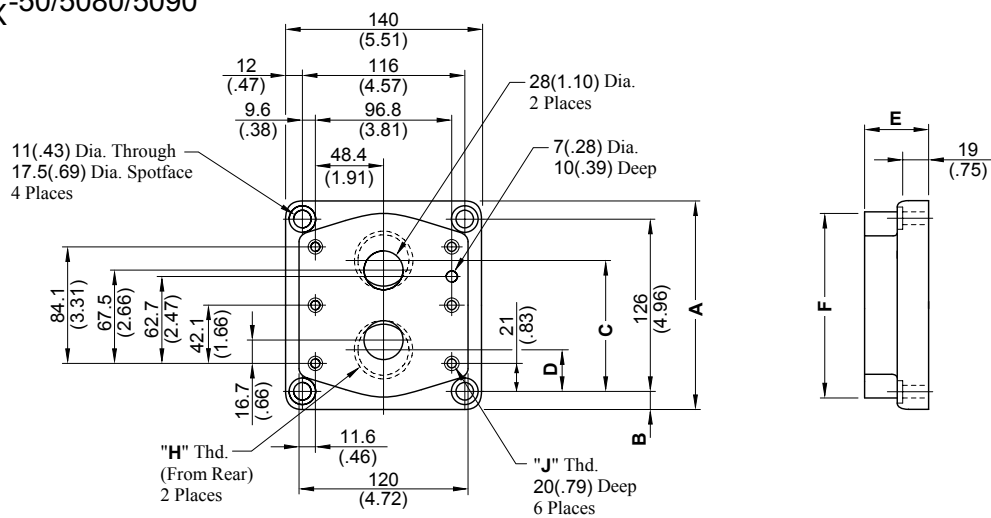

Sub-plate Model Numbers	Dimensions mm (Inches)						"H" Thd.	"J" Thd.
	A	B	C	D	E	F		
CRGM-10-50	150 (5.91)	12 (.47)	96 (3.78)	30 (1.18)	45 (1.77)	135 (5.31)	Rc 1-1/4	M10
CRGM-10-5080							1-1/4 BSP.F	
CRGM-10-5090							1-1/4 NPT	
CRGM-10X-50	177 (6.97)	25.5 (1.00)	104 (4.09)	22 (.87)	50 (1.97)	167 (6.57)	Rc 1-1/2	M10
CRGM-10X-5080							1-1/2 BSP.F	
CRGM-10X-5090							1-1/2 NPT	

Hydraulic Fluid: Viscosity 30 mm²/s (141 SSU), Specific Gravity 0.850

Metred Flow vs Adjustment Handle Revolutions

ΔP: Differential Pressure MPa (PSI)

● SRT-03, SRCT-03 SRG-03, SRCG-03

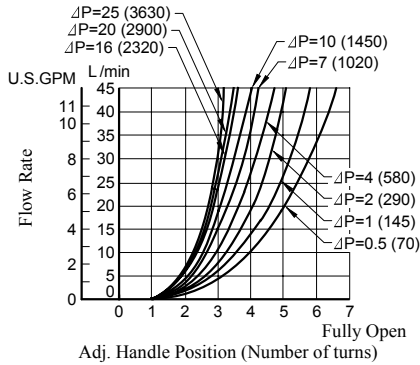

● SRT-06, SRCT-06 SRG-06, SRCG-06

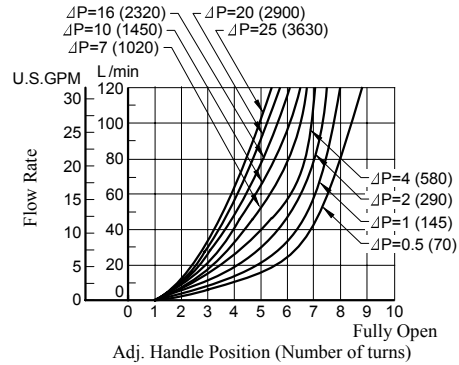

● SRT-10, SRCT-10 SRG-10, SRCG-10

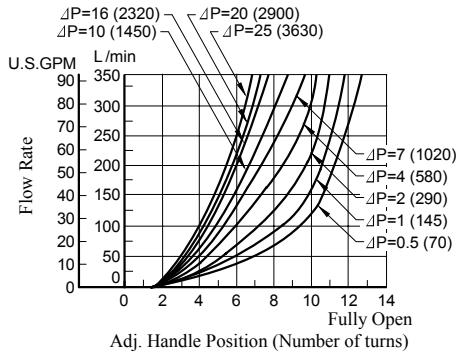

Pressure Drop

● SRT-03, SRCT-03 SRG-03, SRCG-03

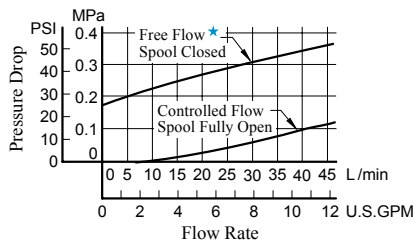

● SRT-06, SRCT-06 SRG-06, SRCG-06

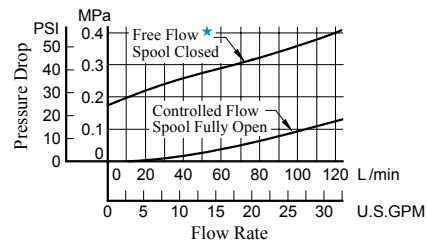

● SRT-10, SRCT-10 SRG-10, SRCG-10

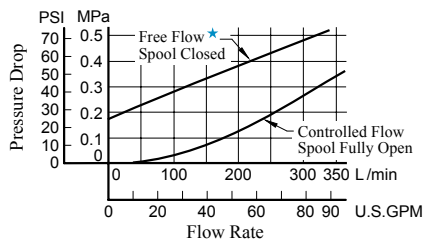

★ Applicable only for one way restrictor (Model No. SRC*)

SRT/SRCT-03-50/5080/5090
SRT/SRCT-06-50/5080/5090
SRT/SRCT-10-50/5080/5090

CAUTION

When making replacement of seals, please do it carefully after reading through the relevant instructions in the Operator's Manual.

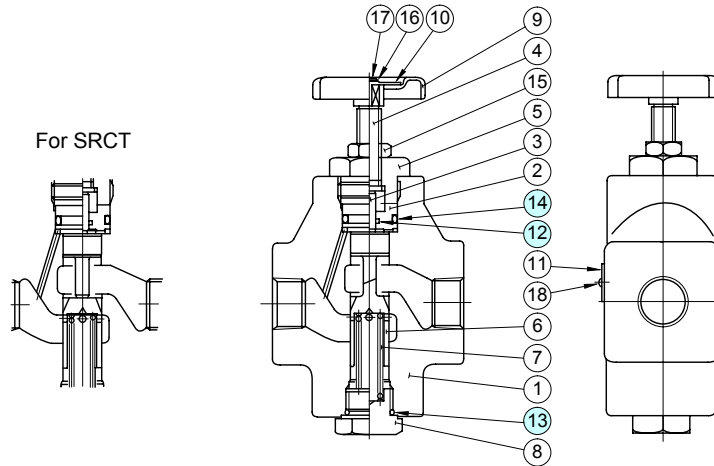

List of Seals

Item	Name of Parts	Part Numbers			Qty.
		SRT SRCT-03	SRT SRCT-06	SRT SRCT-10	
12	O-Ring	SO-NB-P7	SO-NB-P7	SO-NB-P7	1
13	O-Ring	SO-NB-P15	SO-NB-P21	SO-NB-P29	1
14	O-Ring	SO-NB-P20	SO-NB-P22.4	SO-NB-P36	1

Note: When ordering the seals, please specify the seal kit number from the table right.

List of Seal Kits

Model Numbers	Seal Kit Numbers
SRT/SRCT-03	KS-SRT-03-50
SRT/SRCT-06	KS-SRT-06-50
SRT/SRCT-10	KS-SRT-10-50

SRG/SRCG-03-50/5090
SRG/SRCG-06-50/5090
SRG/SRCG-10-50/5090

For SRCG

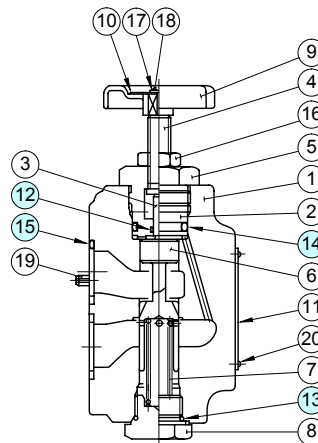
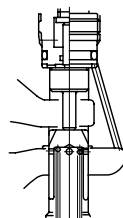

List of Seals

Item	Name of Parts	Part Numbers			Qty.
		SRG SRCG-03	SRG SRCG-06	SRG SRCG-10	
12	O-Ring	SO-NB-P7	SO-NB-P7	SO-NB-P7	1
13	O-Ring	SO-NB-P15	SO-NB-P21	SO-NB-P29	1
14	O-Ring	SO-NB-P20	SO-NB-P22.4	SO-NB-P36	1
15	O-Ring	SO-NB-P18	SO-NB-P28	SO-NB-P32	2

Note: When ordering the seals, please specify the seal kit number from the table right.

List of Seal Kits

Model Numbers	Seal Kit Numbers
SRG/SRCG-03	KS-SRG-03-50
SRG/SRCG-06	KS-SRG-06-50
SRG/SRCG-10	KS-SRG-10-50