



FLOW CONTROL AND RELIEF VALVES FBG-03/06/10 (3/8, 3/4, 1-1/4) Sub-plate Mounting

FLOW CONTROLS

Model Number Designation / Specifications

Up to 25 MPa (3630 PSI), 500 L/min (132 U.S.GPM)

These valves are flow control valves having the functions of metre-in type flow control and pressure control. Inlet pressure is always maintained 0.6 MPa (87 PSI) higher than the load pressure. In a conventional flow control method, power consumption is wasteful since the pump pressure goes up to the preset system pressure regardless of the load pressure. While, the power saving valves control the pump pressure by maintaining a differential pressure as little as 0.6 MPa (87 PSI) against the load pressure, thereby, the power can be remarkably saved. Moreover, with lthe temperature compensator, a stable flow control can be made regardless of oil temperature. Setting and repeat setting of flow can be made easily with an adjustment knob having digital scales.

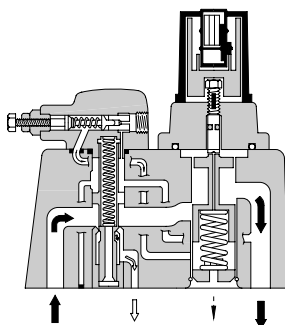

Graphic Symbol

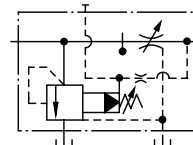

Specifications

Description	Model Numbers	FBG-03-125	FBG-06-250	FBG-10-500
Max. Operating Pressure	MPa (PSI)	25 (3630)	25 (3630)	25 (3630)
	L/min (U.S.GPM)	125 (33)	250 (66)	500 (132)
Metred Flow Range	L/min (U.S.GPM)	1-125 (.26-33)	3-250 (.79-66)	5-500 (1.3-132)
Pressure Adjustment Range	MPa (PSI)	★-25 (★-3630) *	★-25 (★-3630) *	★-25 (★-3630) *
Min. Pressure Difference Required between Inlet and Outlet Ports	MPa (PSI)	0.6 (87)	0.7 (102)	0.9 (131)
Pilot Drain Flow	L/min (U.S.GPM)	1.5 (.40)	2.4 (.63)	3.5 (.92)
Max. Drain Line and Tank Line Back Pressure	MPa (PSI)	0.5 (73)	0.5 (73)	0.5 (73)
Approx. Mass	kg (lbs.)	13.3 (29.3)	27.3 (60.2)	57.3 (126)

* See the "Min. Adjustment Pressure" for the item marked ★ .

Model Number Designation

F-	FB	G	-03	-125	-10	*
Special Seals	Series Number	Type of Mounting	Valve Size	Max. Metred Flow L/min (U.S.GPM)	Design Number	Design Standards
F: Special Seals for Phosphate Ester Type Fluids (Omit if not required)	FB: Flow Control and Relief Valves	G: Sub-plate Mounting	03	125 : 125 (33)	10	Refer to ★1
			06	250 : 250 (66)	10	
			10	500 : 500 (132)	10	

★ 1. Design Standards :

- None. Japanese Standard "JIS" and European Design Standard
- 90 N. American Design Standard

Hydraulic Fluids

Fluid Types

Any type of hydraulic fluids listed in the table below can be used.

Petroleum base oils	Use fluids equivalent to ISO VG32 or VG46.
Synthetic fluids	Use phosphate ester or polyol ester fluid. When phosphate ester fluid is used, prefix "F-" to the model number because the special seals (fluororubber) are required to be used.
Water containing fluids	Use water-glycol fluid.

Note: For use with hydraulic fluids other than those listed above, please consult your Yuken representatives in advance.

Recommended Viscosity and Oil Temperatures

Viscosity ranging between 15 - 400 mm²/s (77 - 1800 SSU).

Oil temperatures between -15/+70°C (5 - 158°F).

Use hydraulic fluids which satisfy the recommended viscosity and oil temperatures given above.

Control of Contamination

Due caution must be paid to maintaining control over contamination of the hydraulic fluids which may otherwise lead to breakdowns and shorten the life of the valves. Please maintain the degree of contamination within NAS 1638-Grade 12. Use 25 μm or finer line filter.

Instructions

Flow adjustment

Loosen the locking screw and turn the flow adjustment handle clockwise to increase, and anti-clockwise to decrease. Open condition is indicated in digital-scale in built-in revolution indicator (Refer to characteristics of "Metred flow vs. Dial Position").

After flow adjustments, tighten the locking screw.

Pressure adjustment

To adjust the pressure, loosen the lock nut and turn the pressure adjustment screw slowly clockwise to increase pressures or anti-clockwise to decrease pressure. After adjustments, do not forget to tighten the lock nut.

Drain port back pressure

Note that any drain port back pressure is added to the minimum pressure.

Connect the drain port, preferably with its back pressure minimized, directly to the oil tank.

Relief valve throughput

When the relief valve throughput is small with pressure under control, the pressure setting may become unstable.

Thus, hold the rate above 10 L/min (2.6 U.S.GPM) for nominal valve size 03 and 06 or above 15 L/min (4 U.S. GPM) for nominal valve size 10.

Line filter

In case of controlling flow rate of less than 2 L/min (.53 U.S.GPM), be sure to use a line filter of 10μm or finer at the valve inlet.

Attachment

Mounting Bolts

Valve Model Numbers	Socket Head Cap Screw			Qty.
	Japanese Std. "JIS" and European Design Std.		N. American Design Std.	
FBG-03	M10 × 100 Lg.		3/8-16 UNC × 4 Lg.	4
FBG-06	M16 × 130 Lg.		5/8-11 UNC × 5 Lg.	4
FBG-10	M20 × 130 Lg.		3/4-10 UNC × 5 Lg.	4

Sub-plate

Valve Model Numbers	Japanese Standard "JIS"		European Design Standard		N. American Standard		Approx. Mass kg (lbs.)
	Sub-plate Model No.	Thread Size	Sub-plate Model No.	Thread Size	Sub-plate Model No.	Thread Size	
FBG-03	EFBGM-03Y-10	Rc 3/4	EFBGM-03Y-1080	3/4 BSP.F	EFBGM-03Y-1090	3/4 NPT	6 (13.2)
	EFBGM-03Z-10	Rc 1	EFBGM-03Z-1080	1 BSP.F	EFBGM-03Z-1090	1 NPT	6 (13.2)
FBG-06	EFBGM-06X-10	Rc 1	EFBGM-06X-1080	1 BSP.F	EFBGM-06X-1090	1 NPT	12.5 (27.6)
	EFBGM-06Y-10	Rc 1-1/4	EFBGM-06Y-1080	1-1/4 BSP.F	EFBGM-06Y-1090	1-1/4 NPT	16 (35.3)
FBG-10	EFBGM-10Y-10	1-1/2, 2	EFBGM-10Y-1080	1-1/2, 2	EFBGM-10Y-1090	1-1/2, 2	37 (81.6)

Sub-plates are available. Specify the sub-plate model number from the table above. When sub-plates are not used, the mounting surface should have a good machined finish.

EFBGM-10Y is special type sub-plates to be used with pipe flange. When ordering EFBGM-10Y, specify pipe flange in addition to EFBGM-10Y referring to F3 pipe flange catalogue (No. Pub. EC-3001).

FBG-03-125-10/1090

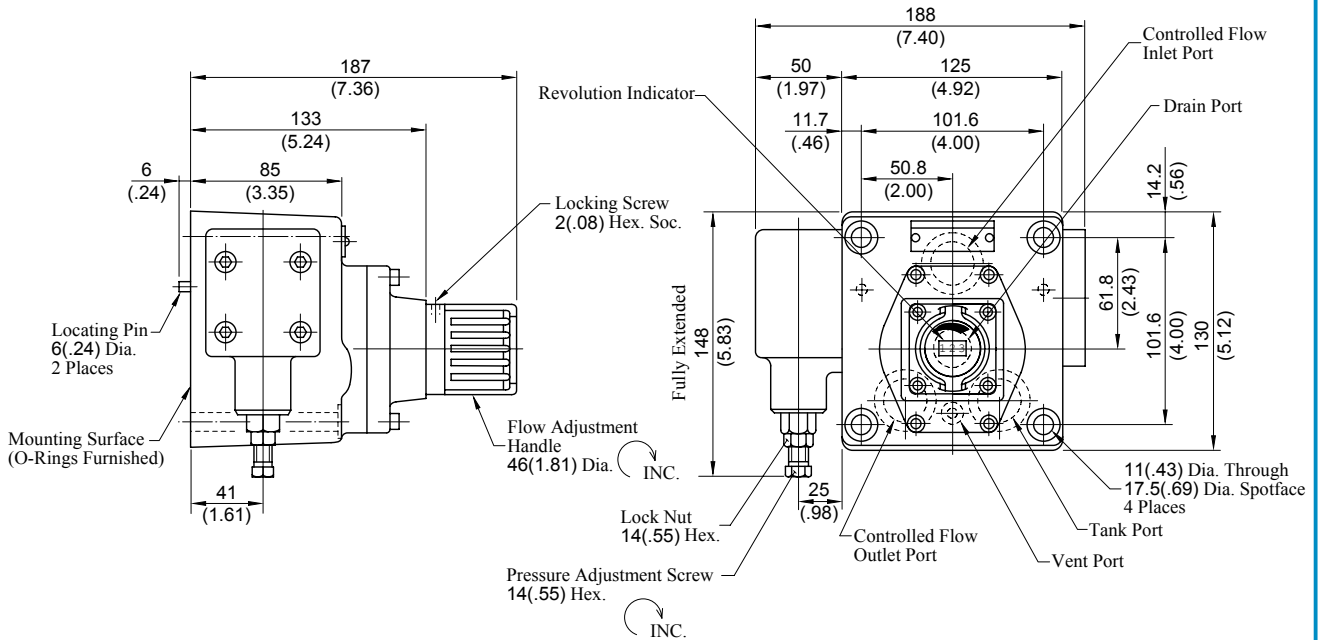

**DIMENSIONS IN
MILLIMETRES (INCHES)**

Sub-plate

EFBGM-03Y/03Z-10/1080/1090

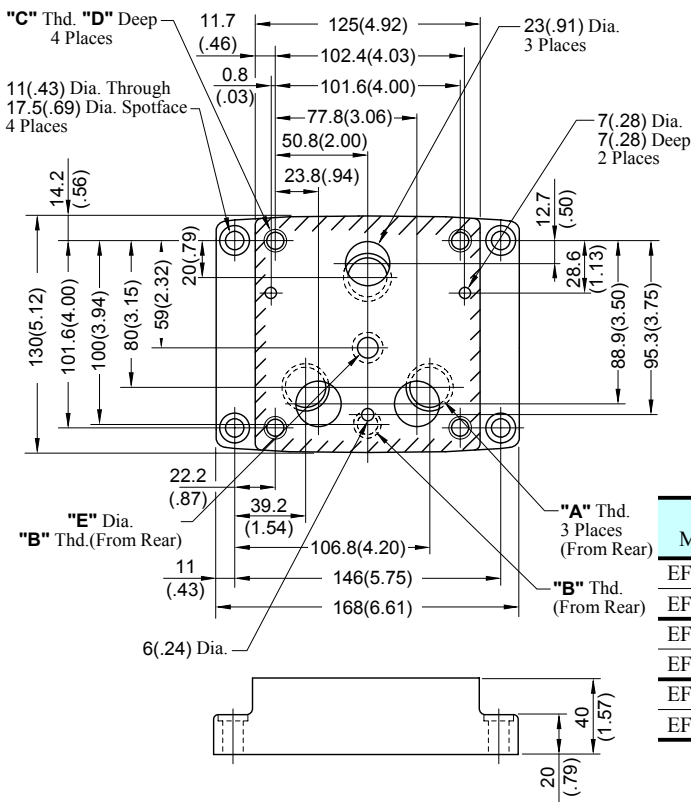

Sub-plate Model Numbers	Thread Size			D	E
	"A" Thd.	"B" Thd.	"C" Thd.		
EFBGM-03Y-10	Rc 3/4	Rc 1/4	M10	18 (.71)	11 (.43)
EFBGM-03Z-10	Rc 1				11.7 (.46)
EFBGM-03Y-1080	3/4 BSP.F	1/4 BSP.F			11 (.43)
EFBGM-03Z-1080	1 BSP.F				11.7 (.46)
EFBGM-03Y-1090	3/4 NPT	1/4 NPT	3/8-16 UNC	21 (.83)	11 (.43)
EFBGM-03Z-1090	1 NPT				11 (.43)

FBG-06-250-10/1090

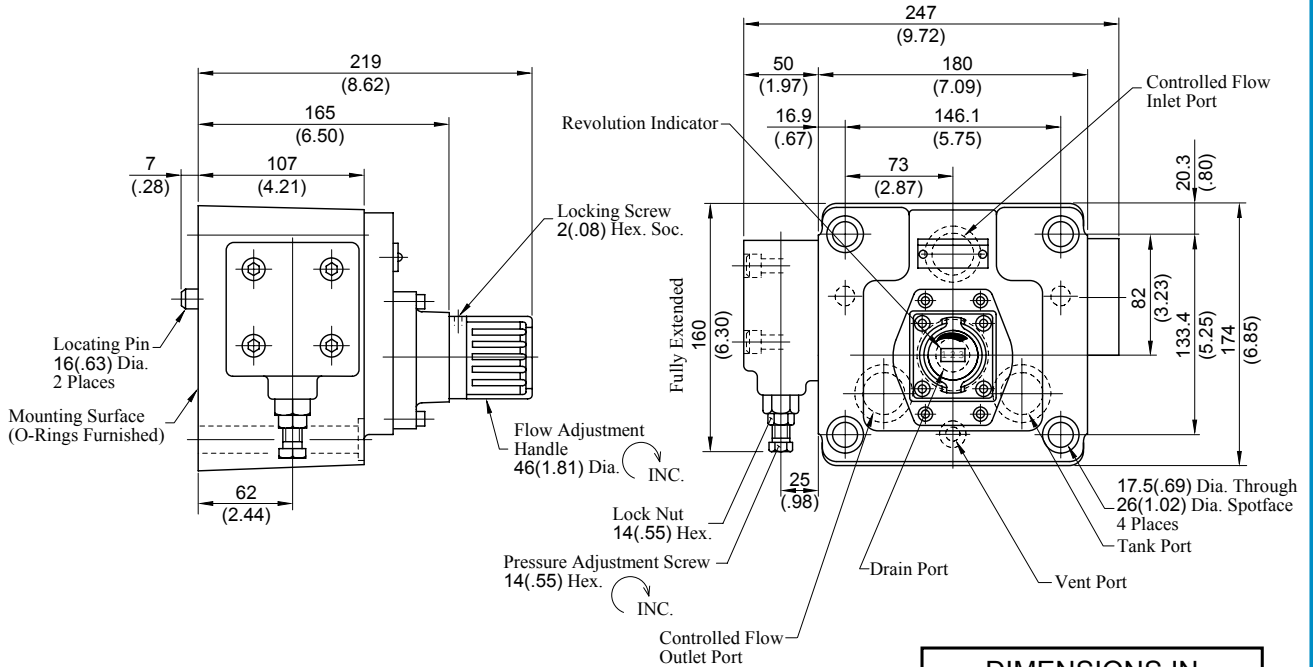

**DIMENSIONS IN
MILLIMETRES (INCHES)**

Sub-plate

EFBGM-06X/06Y-10/1080/1090

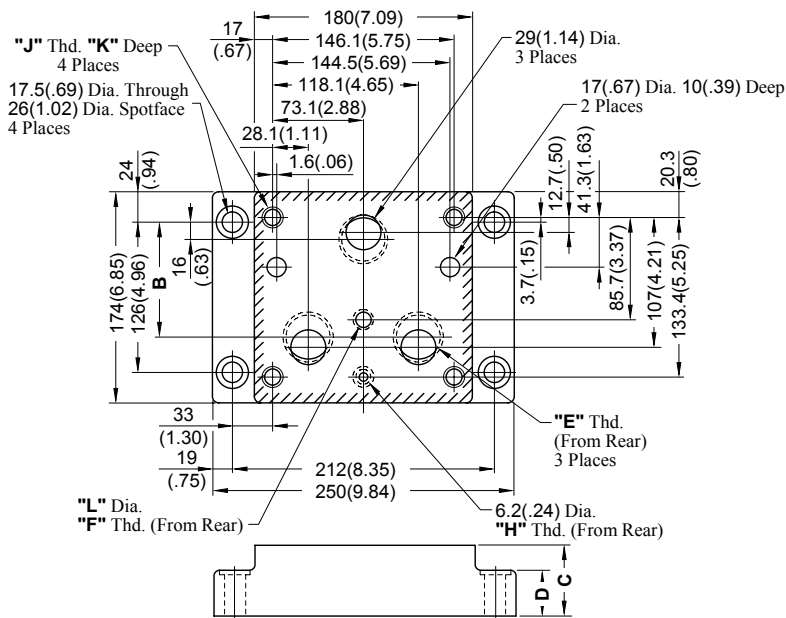

Sub-plate Model No.	Dimensions mm (IN.)		
	B	C	D
EFBGM-06X	103.3 (4.07)	45 (1.77)	35 (1.38)
EFBGM-06Y	95 (3.74)	60 (2.36)	40 (1.57)

Sub-plate Model No.	Thread Size				mm (IN.)	
	"E" Thd.	"F" Thd.	"H" Thd.	"J" Thd.	K	L
EFBGM-06X-10	Rc 1	Rc 3/8	Rc 1/4	M 16	30	14
EFBGM-06Y-10	Rc 1-1/4				(1.18)	(.55)
EFBGM-06X-1080	1 BSP.F	3/8 BSP.F	1/4 BSP.F	M 16	30	15.2
EFBGM-06Y-1080	1-1/4 BSP.F				(1.18)	(.60)
EFBGM-06X-1090	1 NPT	3/8 NPT	1/4 NPT	5/8-11 UNC	35	14
EFBGM-06Y-1090	1-1/4 NPT				(1.38)	(.55)

■ Min. Adjustment Pressure

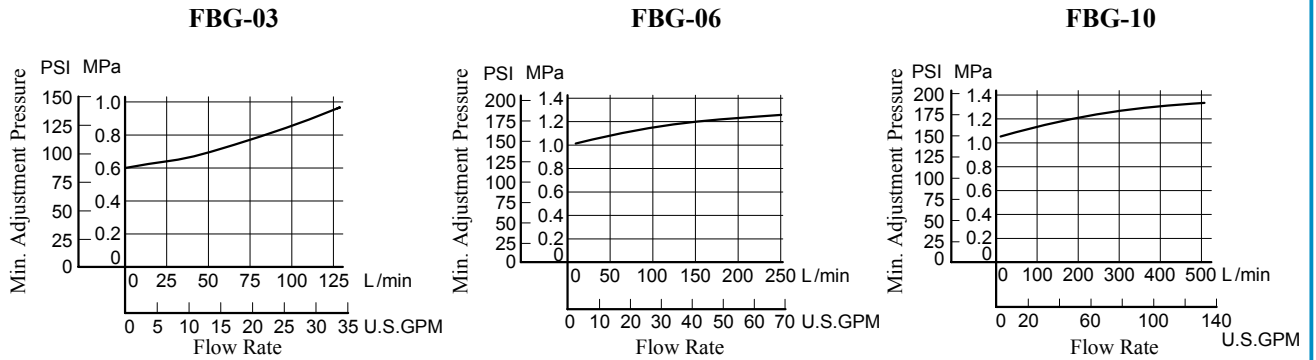

■ Load Pressure vs. Metred Flow

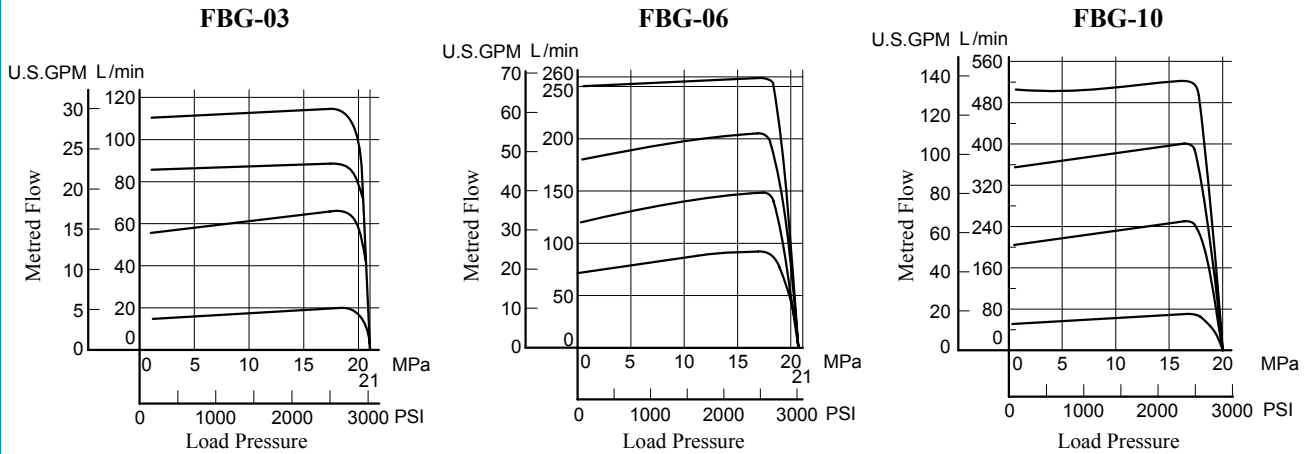

■ Metred Flow vs. Dial Position

Loading Pressure : 7 MPa(1020 PSI)

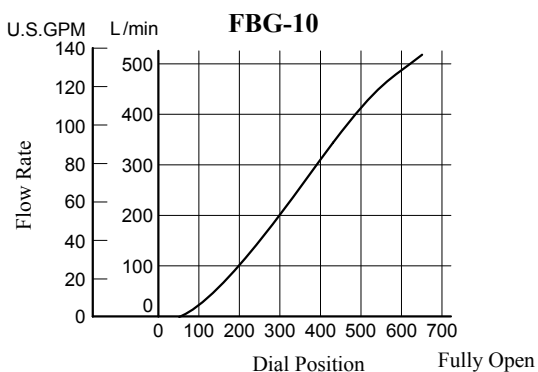
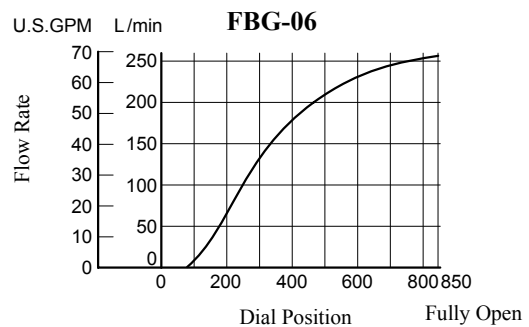
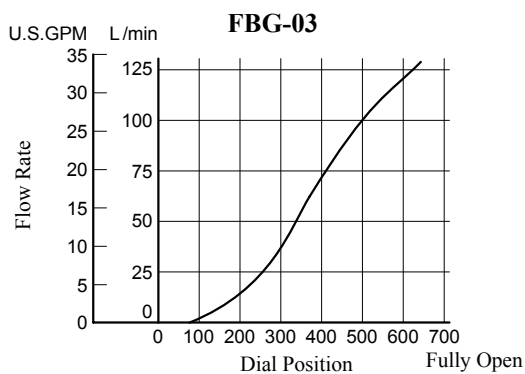

FBG-03-125-10/1090
FBG-06-250-10/1090
FBG-10-500-10/1090

CAUTION

When making replacement of seals, please do it carefully after reading through the relevant instructions in the Operator's Manual.

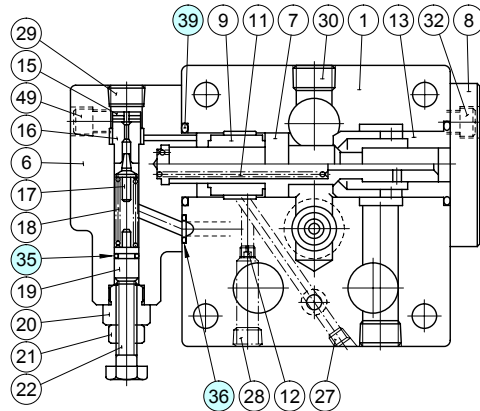

Section X-X

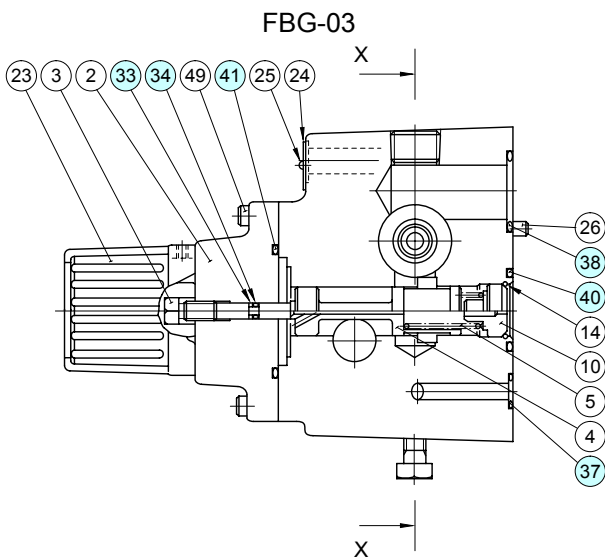

FBG-03

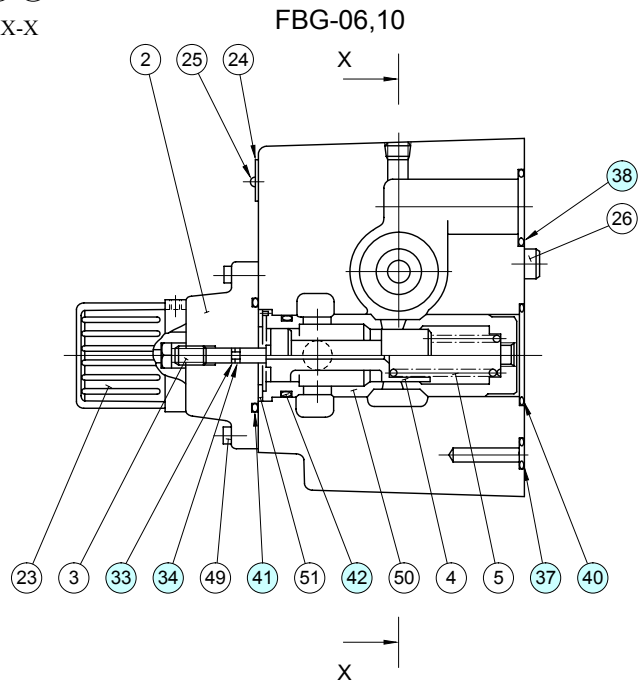

FBG-06,10

List of Seals

Item	Name of Parts	Part Numbers			Qty.
		FBG-03	FBG-06	FBG-10	
33	Back Up Ring	SO-BB-P4	SO-BB-P4	SO-BB-P4	1
34	O-Ring	SO-NA-P4	SO-NA-P4	SO-NA-P4	1
35	O-Ring	SO-NA-P9	SO-NA-P9	SO-NA-P9	1
36	O-Ring	SO-NB-P9	SO-NB-P9	SO-NB-P11	1
37	O-Ring	SO-NB-P11	SO-NB-P11	SO-NB-P11	1
38	O-Ring	SO-NB-P28	SO-NB-P32	SO-NB-P48	3
39	O-Ring	SO-NB-P32	SO-NB-P42	SO-NB-G55	2
40	O-Ring	SO-NB-G30	SO-NB-P44	SO-NB-G60	1
41	O-Ring	SO-NB-G50	SO-NB-G50	SO-NB-G50	1
42	O-Ring	—	SO-NB-P34	SO-NB-P50	1

Note: When ordering the seals, please specify the seal kit number from the table right.

List of Seal Kits

Model Numbers	Seal Kit Numbers
FBG-03	KS-FBG-03-10
FBG-06	KS-FBG-06-10
FBG-10	KS-FBG-10-10