



PRESSURE REDUCING (AND CHECK) VALVES

**RT/RG
RCT/RCG -03/06/10 (3/8, 3/4, 1-1/4)**

Threaded Connections / Sub-plate Mounting

**PRESSURE
CONTROLS**

Up to 21 MPa (3050 PSI), 500 L/min (132 U.S.GPM)

■ **Pressure Reducing Valves**

Pressure reducing valves are used to set the pressure of a hydraulic circuit below that of the main circuit. In addition, operation under remote control is possible by using the remote control port.

■ **Pressure Reducing and Check Valves**

Pressure reducing and check valves are used to set the pressure of a hydraulic circuit below that of the main circuit. They have check valves, which allow a free flow from the secondary side to the primary. Operation under remote control is also possible by using the remote control port.

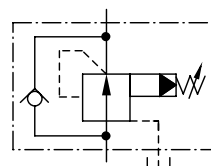
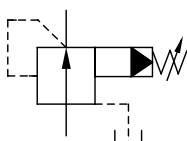
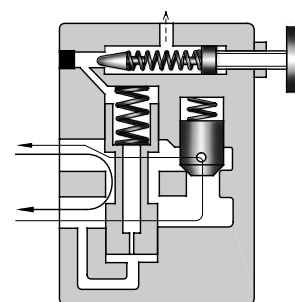
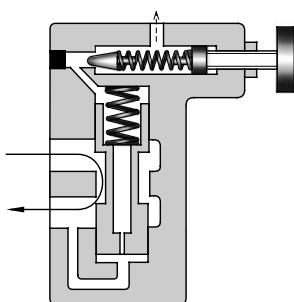

■ **Hydraulic Fluids**

● **Fluid Types**

Any type of hydraulic fluid listed in the table below can be used.

Petroleum base oils	Use fluids equivalent to ISO VG 32 or VG 46.
Synthetic fluids	Use phosphate ester or polyol ester fluid. When phosphate ester fluid is used, prefix "F-" to the model number because the special seals (fluororubber) are required to be used.
Water containing fluids	Use water-glycol fluid.

Note: For use with hydraulic fluids other than those listed above, please consult your Yuken representatives in advance.

● **Recommended Viscosity and Oil Temperatures**

Viscosity ranging between 15 - 400 mm²/s (77 - 1800 SSU).

Oil temperatures between -15/+70°C (5 - 158°F).

Use hydraulic fluids which satisfy the recommended viscosity and oil temperatures given above.

● **Control of Contamination**

Due caution must be paid to maintaining control over contamination of the hydraulic fluids which may otherwise lead to breakdowns and shorten the life of the valves. Please maintain the degree of contamination within NAS 1638-Grade 12. Use 25 μm or finer line filter.



Specifications

Valve Name	Model Numbers		Max. Operating Pressure MPa (PSI)	Max. Flow ^{★1}		Drain Flow ^{★2} L/min (U.S.GPM)	Approx. Mass kg (lbs.)	
	Threaded Connection	Sub-plate Mounting		Setting Pressure MPa (PSI)	Max. Flow L/min (U.S.GPM)		Threaded Connection	Sub-plate Mounting
Pressure Reducing Valve	RT-03-* -22*	RG-03-* -22*	21 (3050)	0.7 - 1.0 (102 - 145)	40 (10.6)	0.8 - 1.0 (.21 - .26)	4.3 (9.5)	4.5 (9.9)
				1.0 - 20.5 (145 - 2970)	50 (13.2)			
	RT-06-* -22*	RG-06-* -22*	21 (3050)	0.7 - 1.0 (102 - 145)	50 (13.2)	0.8 - 1.1 (.21 - .29)	6.9 (15.2)	6.8 (15.0)
				1.0 - 1.5 (145 - 220)	100 (26.4)			
				1.5 - 20.5 (220 - 2970)	125 (33.0)			
	RT-10-* -22*	RG-10-* -22*	21 (3050)	0.7 - 1.0 (102 - 145)	130 (34.3)	1.2 - 1.5 (.31 - .40)	12.0 (26.5)	11.0 (24.3)
				1.0 - 1.5 (145 - 220)	180 (47.5)			
				1.5 - 10.5 (220 - 1520)	220 (58.1)			
				10.5 - 20.5 (1520 - 2970)	250 (66.0)			
Pressure Reducing and Check Valve	RCT-03-* -22*	RCG-03-* -22*	21 (3050)	0.7 - 1.0 (102 - 145)	40 (10.6)	0.8 - 1.0 (.21 - .26)	4.8 (10.6)	5.4 (11.9)
				1.0 - 20.5 (145 - 2970)	50 (13.2)			
	RCT-06-* -22*	RCG-06-* -22*	21 (3050)	0.7 - 1.0 (102 - 145)	50 (13.2)	0.8 - 1.1 (.21 - .29)	7.8 (17.2)	8.1 (17.9)
				1.0 - 1.5 (145 - 220)	100 (26.4)			
				1.5 - 20.5 (220 - 2970)	125 (33.0)			
	RCT-10-* -22*	RCG-10-* -22*	21 (3050)	0.7 - 1.0 (102 - 145)	130 (34.3)	1.2 - 1.5 (.31 - .40)	13.8 (30.4)	13.8 (30.4)
				1.0 - 1.5 (145 - 220)	180 (47.5)			
				1.5 - 10.5 (220 - 1520)	220 (58.1)			
				10.5 - 20.5 (1520 - 2970)	250 (66.0)			

★1. The max. flow rates are those shown at the primary pressure at 21 MPa (3050 PSI).

★2. The drain flow rates are equal to pilot flow rates when differential pressure between primary and secondary pressure is at 20.5 MPa (2970 PSI).

Graphic Symbols

● RT / RG

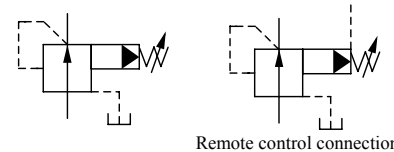

● RCT / RCG

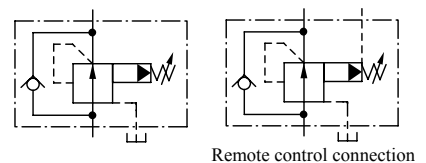

Yuken can offer flanged connection valves described below.

For details, contact us.

Model Numbers	Max. Operating Pressure MPa (PSI)	Max. Flow L/min (U.S.GPM)
RF/RCF-10-* -22*	21 (3050)	250 (66)
RF/RCF-16-* -20*		500 (132)

Model Number Designation

F-	R	T	-03	-B	-22	*
Special Seals	Series Number	Type of Mounting	Valve Size	Pres. Adj. Range MPa (PSI)	Design Number	Design Standards
F: Special Seals for Phosphate Ester Type Fluids (Omit if not required)	R: Pressure Reducing Valves	T: Threaded Connection	03	B: 0.7-7 (102-1020) C: 3.5-14 (510-2030) H: 7-20.5 (1020-2970)	22	None: Japanese Std. "JIS" 80: European Design Std. 90: N.American Design Std.
			06		22	
			10		22	
		G: Sub-plate Mounting	03		22	
			06		22	
			10		22	
	RC: Pressure Reducing and Check Valves	T: Threaded Connection	03	22		
			06	22		
			10	22		
		G: Sub-plate Mounting	03	22		
			06	22		
			10	22		

■ Attachment

● Mounting bolts

Valve Model Numbers	Socket Head Cap Screw		Qty.
	Japanese Std. "JIS" and European Design Std.	N. American Design Std.	
RG-03	M10 × 50 Lg.	3/8-16 UNC × 2 Lg.	4
RG-06	M10 × 50 Lg.	3/8-16 UNC × 2 Lg.	4
RG-10	M10 × 50 Lg.	3/8-16 UNC × 2 Lg.	6
RCG-03	M10 × 70 Lg.	3/8-16 UNC × 2-3/4 Lg.	4
RCG-06	M10 × 80 Lg.	3/8-16 UNC × 3-1/4 Lg.	4
RCG-10	M10 × 90 Lg.	3/8-16 UNC × 3-1/2 Lg.	6

■ Sub-plate

Valve Model Numbers	Japanese Standard "JIS"		European Design Standard		N. American Design Standard		Approx. Mass kg (lbs.)
	Sub-plate Model Numbers	Thread Size	Sub-plate Model Numbers	Thread Size	Sub-plate Model Numbers	Thread Size	
RG RCG ⁻⁰³	HGM-03-20	Rc 3/8	HGM-03-2080	3/8 BSP.F	HGM-03-2090	3/8 NPT	1.6 (3.5)
	HGM-03X-20	Rc 1/2	HGM-03X-2080	1/2 BSP.F	HGM-03X-2090	1/2 NPT	
RG RCG ⁻⁰⁶	HGM-06-20	Rc 3/4	HGM-06-2080	3/4 BSP.F	HGM-06-2090	3/4 NPT	2.4 (5.3)
	HGM-06X-20	Rc 1	HGM-06X-2080	1 BSP.F	HGM-06X-2090	1 NPT	3.0 (6.6)
RG RCG ⁻¹⁰	HGM-10-20	Rc 1-1/4	HGM-10-2080	1-1/4 BSP.F	HGM-10-2090	1-1/4 NPT	4.8 (10.6)
	HGM-10X-20	Rc 1-1/2	HGM-10X-2080	1-1/2 BSP.F	HGM-10X-2090	1-1/2 NPT	5.7 (12.6)

- Sub-plates are available. Specify the sub-plate model number from the table above. When sub-plates are not used, the mounting surface should have a good machined finish.

■ Instructions

- To adjust the pressure, loosen the lock nut and turn the pressure adjustment handle slowly clockwise for higher pressures and anti-clockwise for lower pressures. After adjustments, do not forget to tighten the lock nut.
- Connect the drain port directly to the tank in which case the pressure at the drain port should be kept at a low back pressure close to the atmospheric pressure.
- There are two threaded connection type primary pressure ports. They can be connected each other in-line; one as an inlet and the other as an outlet or the valve can be used by plugging one of the pressure ports.

RT-03-*/-22/2280/2290

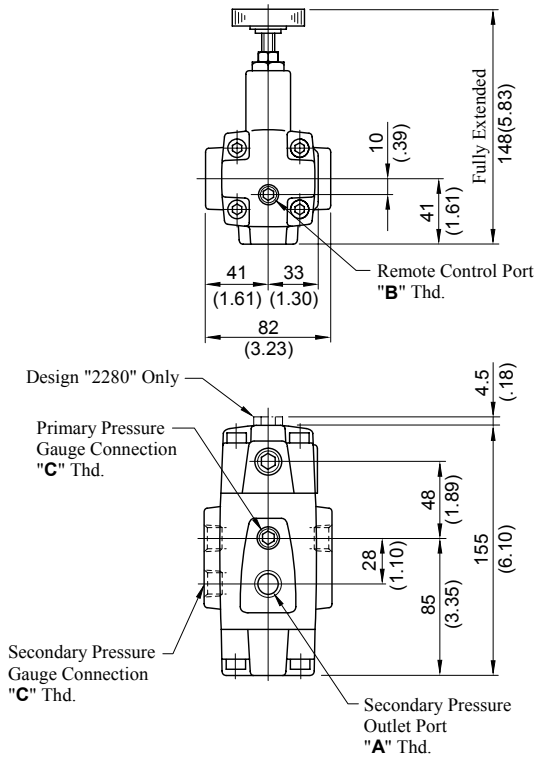

Model Numbers	Thread Size		
	"A" Thd.	"B" Thd.	"C" Thd.
RT-03-*/-22	Rc 3/8	Rc 1/4	Rc 1/4
RT-03-*/-2280	3/8 BSP.F	1/4 BSP.F	1/4 BSP.Tr
RT-03-*/-2290	3/8 NPT	1/4 NPT	1/4 NPT

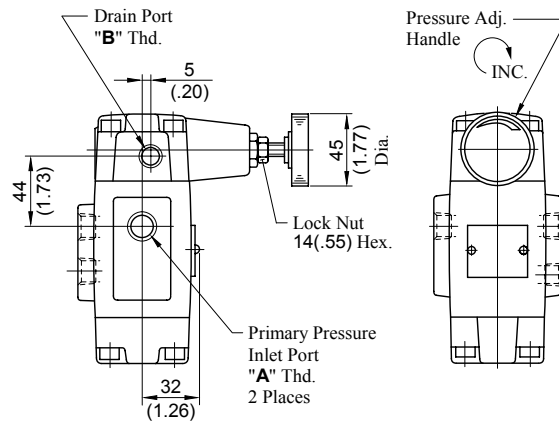

**DIMENSIONS IN
MILLIMETRES (INCHES)**

RT-06-*/-22/2280/2290

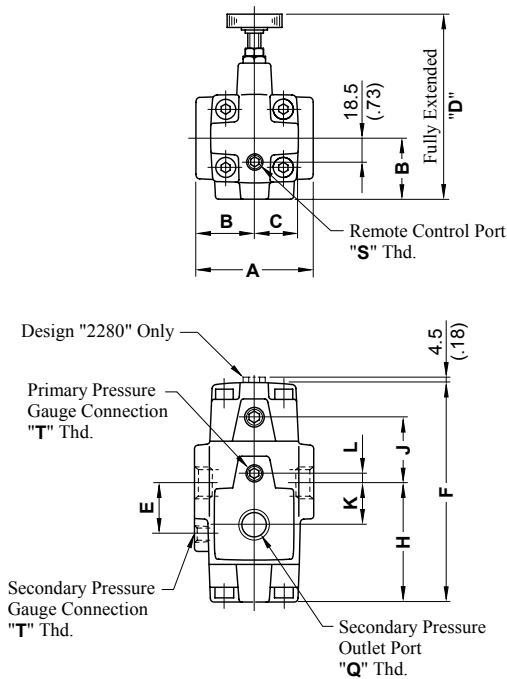

Model Numbers	Thread Size		
	"Q" Thd.	"S" Thd.	"T" Thd.
RT-06-*/-22	Rc 3/4	Rc 1/4	Rc 1/4
RT-06-*/-2280	3/4 BSP.F	1/4 BSP.F	1/4 BSP.Tr
RT-06-*/-2290	3/4 NPT	1/4 NPT	1/4 NPT
RT-10-*/-22	Rc 1-1/4	Rc 1/4	Rc 1/4
RT-10-*/-2280	1-1/4 BSP.F	1/4 BSP.F	1/4 BSP.Tr
RT-10-*/-2290	1-1/4 NPT	1/4 NPT	1/4 NPT

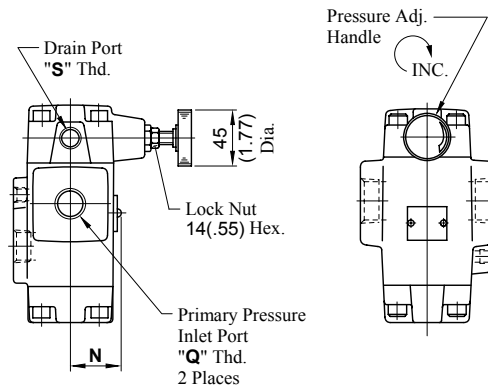

Model Numbers	Dimensions mm (Inches)										
	A	B	C	D	E	F	H	J	K	L	N
RT-06	96 (3.78)	48 (1.89)	36.5 (1.44)	149 (5.87)	42 (1.65)	179 (7.05)	97.5 (3.84)	53.5 (2.11)	33 (1.30)	9 (.35)	39 (1.54)
RT-10	132 (5.20)	66 (2.60)	43 (1.69)	167 (6.57)	52 (2.05)	216 (8.50)	124 (4.88)	64 (2.52)	40 (1.57)	12 (.47)	46 (1.81)

RG-03/06-* -22/2280/2290

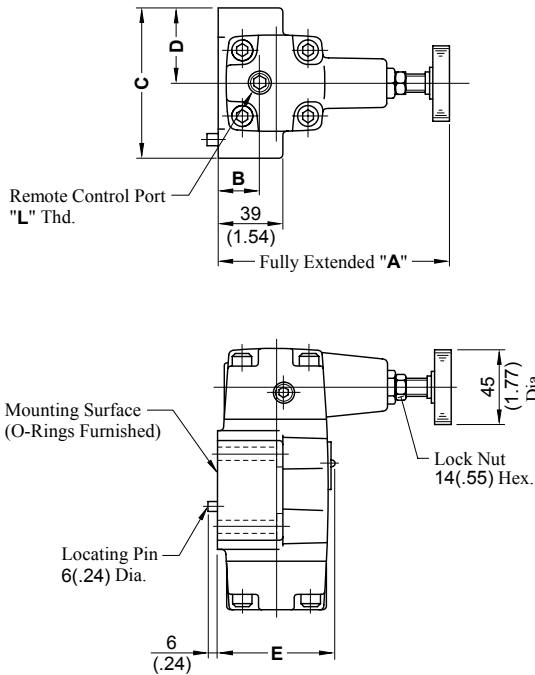

Model Numbers	Thread Size	
	"L" Thd.	"N" Thd.
RG-03/06-* -22	Rc 1/4	Rc 1/4
RG-03/06-* -2280	1/4 BSP.F	1/4 BSP.Tr
RG-03/06-* -2290	1/4 NPT	1/4 NPT

★ Port connection is not required for RG models but an O-ring should be furnished.

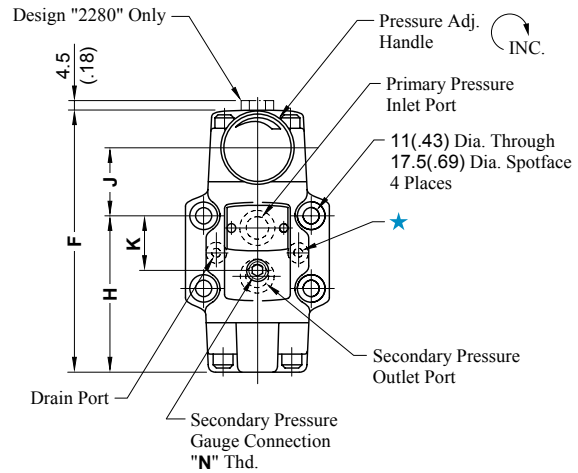

Model Numbers	Dimensions mm (Inches)								
	A	B	C	D	E	F	G	H	J
RG-03	142 (5.59)	25 (.98)	89 (3.50)	44.5 (1.75)	67 (2.64)	155.5 (6.12)	92.4 (3.64)	40.6 (1.60)	34.9 (1.37)
RG-06	141 (5.55)	21.5 (.85)	102 (4.02)	51 (2.01)	79 (3.11)	179 (7.05)	111 (4.37)	40 (1.57)	48 (1.89)

DIMENSIONS IN
MILLIMETRES (INCHES)

RG-10-* -22/2280/2290

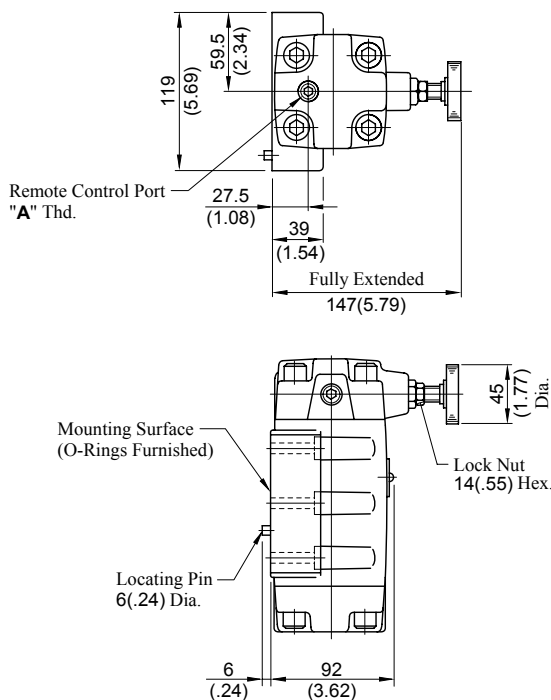

Model Numbers	Thread Size	
	"A" Thd.	"B" Thd.
RG-10-* -22	Rc 1/4	Rc 1/4
RG-10-* -2280	1/4 BSP.F	1/4 BSP.Tr
RG-10-* -2290	1/4 NPT	1/4 NPT

★ Port connection is not required for RG models but an O-ring should be furnished.

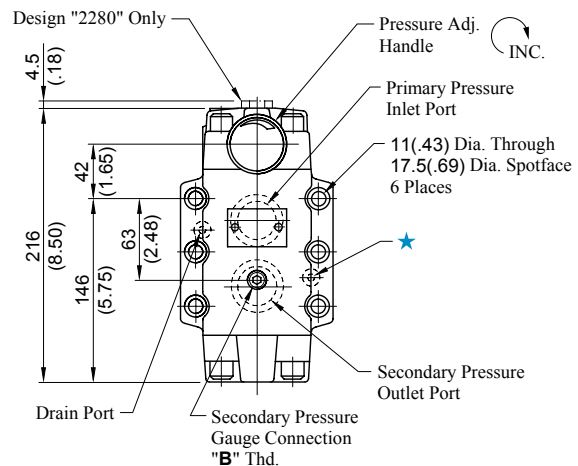

RCT-03-* -22/2280/2290

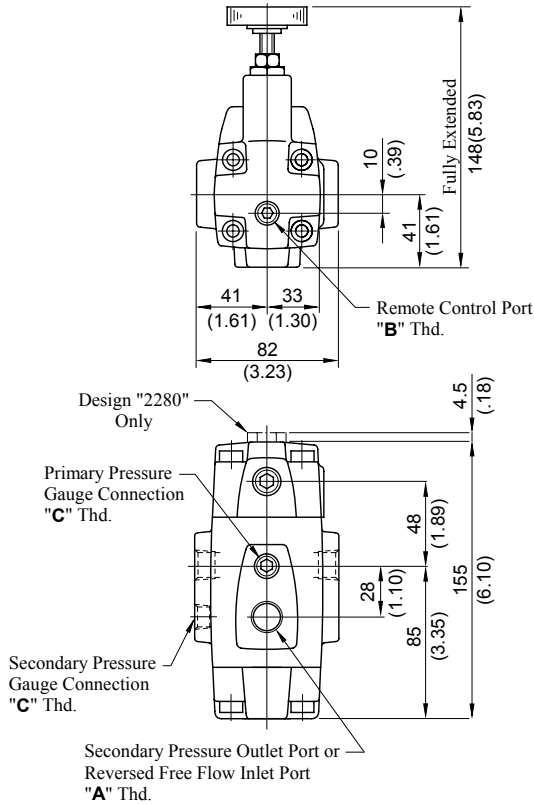

Model Numbers	Thread Size		
	"A" Thd.	"B" Thd.	"C" Thd.
RCT-03-* -22	Rc 3/8	Rc 1/4	Rc 1/4
RCT-03-* -2280	3/8 BSP.F	1/4 BSP.F	1/4 BSP.Tr
RCT-03-* -2290	3/8 NPT	1/4 NPT	1/4 NPT

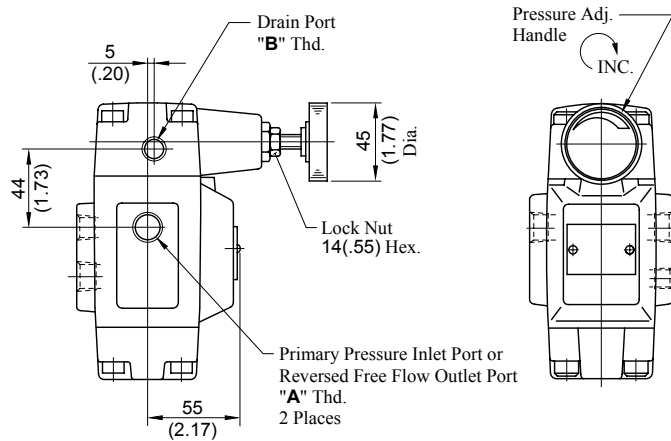

**DIMENSIONS IN
MILLIMETRES (INCHES)**

RCT-06 RCT-10-* -22/2280/2290

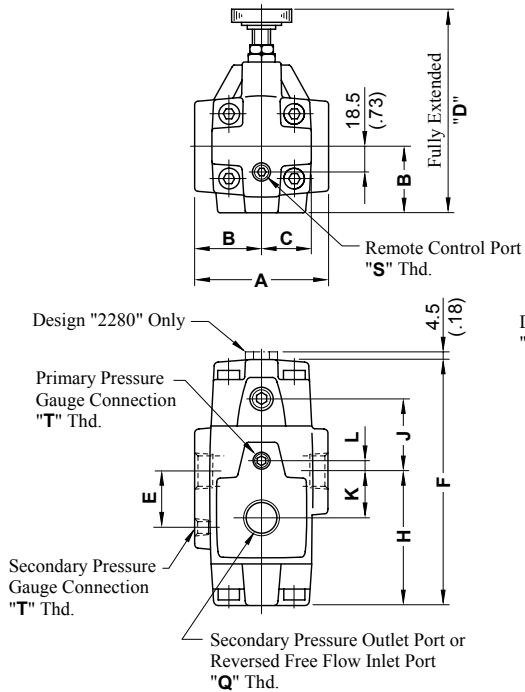

Model Numbers	Thread Size		
	"Q" Thd.	"S" Thd.	"T" Thd.
RCT-06-* -22	Rc 3/4	Rc 1/4	Rc 1/4
RCT-06-* -2280	3/4 BSP.F	1/4 BSP.F	1/4 BSP.Tr
RCT-06-* -2290	3/4 NPT	1/4 NPT	1/4 NPT
RCT-10-* -22	Rc 1-1/4	Rc 1/4	Rc 1/4
RCT-10-* -2280	1-1/4 BSP.F	1/4 BSP.F	1/4 BSP.Tr
RCT-10-* -2290	1-1/4 NPT	1/4 NPT	1/4 NPT

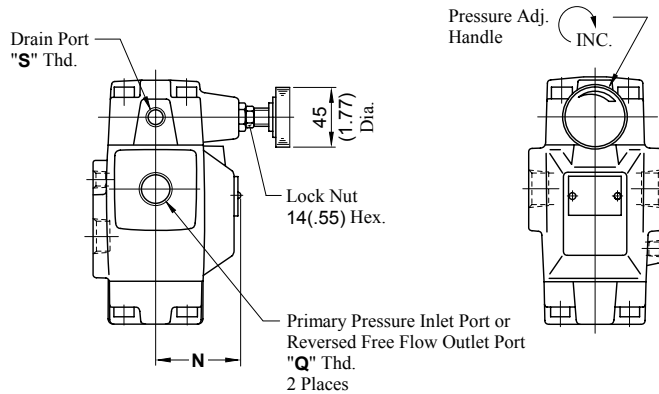

Model Numbers	Dimensions mm (Inches)										
	A	B	C	D	E	F	H	J	K	L	N
RCT-06	96 (3.78)	48 (1.89)	36.5 (1.44)	149 (5.87)	42 (1.65)	179 (7.05)	97.5 (3.84)	53.5 (2.11)	33 (1.30)	9 (.35)	68 (2.68)
RCT-10	132 (5.20)	66 (2.60)	43 (1.69)	167 (6.57)	52 (2.05)	216 (8.50)	124 (4.88)	64 (2.52)	40 (1.57)	12 (.47)	86 (3.39)

RCG-03/06-* -22/2280/2290

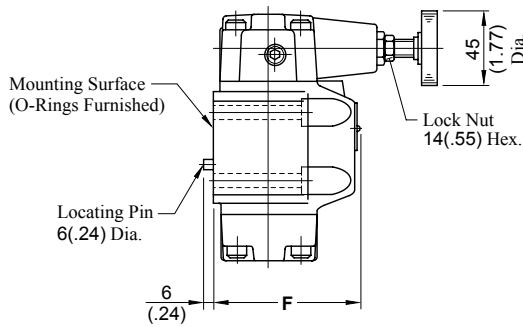
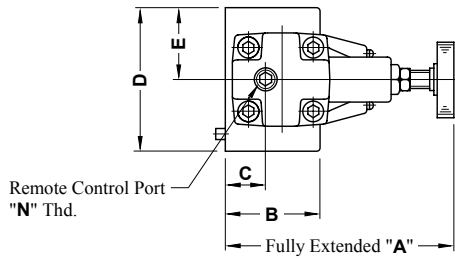

Model Numbers	Thread Size	
	"N" Thd.	"P" Thd.
RCG-03/06-* -22	Rc 1/4	Rc 1/4
RCG-03/06-* -2280	1/4 BSP.F	1/4 BSP.Tr
RCG-03/06-* -2290	1/4 NPT	1/4 NPT

★ Port connection is not required for RCG models but an O-ring should be furnished.

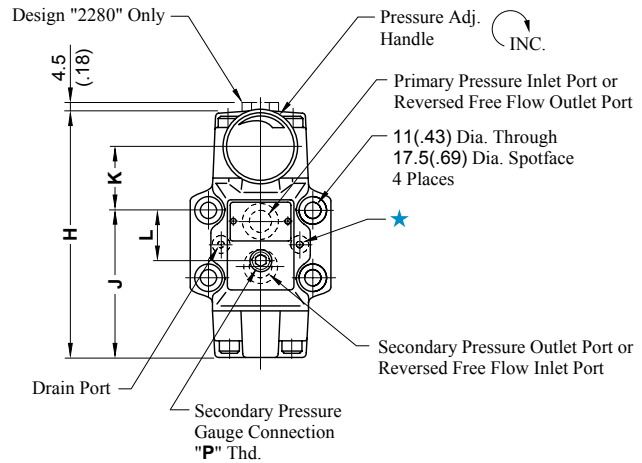

Model Numbers	Dimensions mm (Inches)									
	A	B	C	D	E	F	H	J	K	L
RCG-03	142 (5.59)	59 (2.32)	25 (.98)	89 (3.50)	44.5 (1.75)	90 (3.54)	155 (6.10)	92.4 (3.64)	40.6 (1.60)	34.9 (1.37)
RCG-06	141 (5.55)	69 (2.72)	21.5 (.85)	102 (4.02)	51 (2.01)	108 (4.25)	179 (7.05)	111 (4.37)	40 (1.57)	48 (1.89)

DIMENSIONS IN
MILLIMETRES (INCHES)

RCG-10-* -22/2280/2290

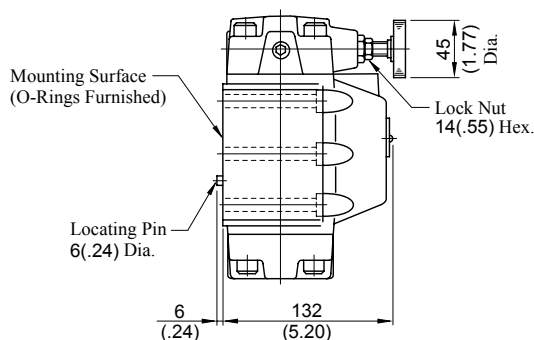
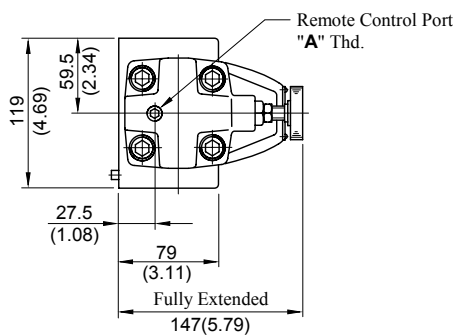

Model Numbers	Thread Size	
	"A" Thd.	"B" Thd.
RCG-10-* -22	Rc 1/4	Rc 1/4
RCG-10-* -2280	1/4 BSP.F	1/4 BSP.Tr
RCG-10-* -2290	1/4 NPT	1/4 NPT

★ Port connection is not required for RCG models but an O-ring should be furnished.

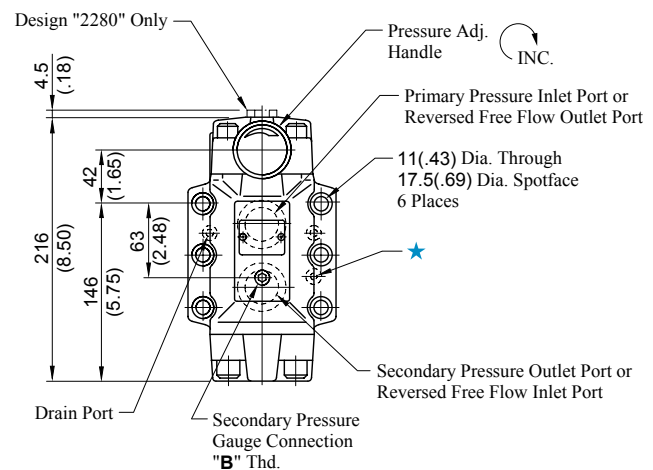

- HGM-03-20/2080/2090
HGM-03X-20/2080/2090

DIMENSIONS IN
MILLIMETRES (INCHES)

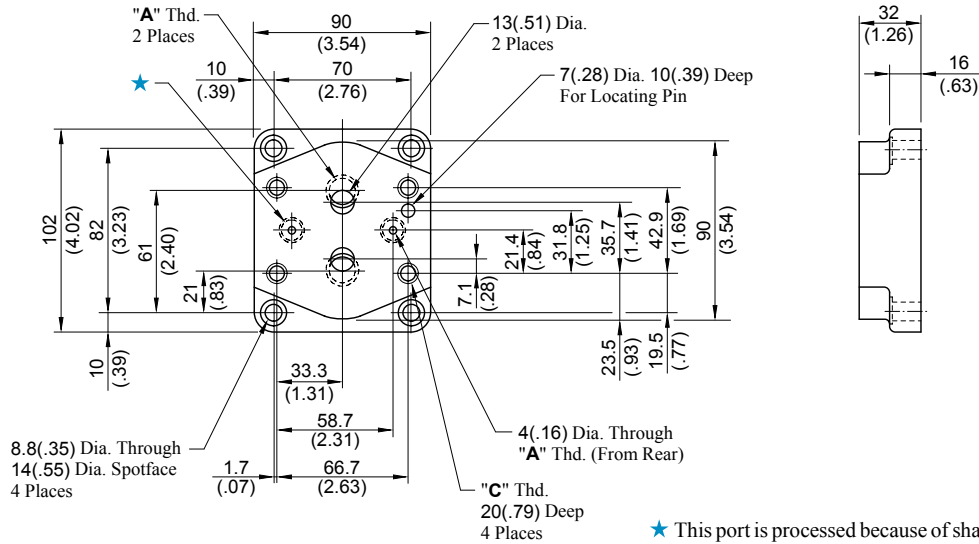

★ This port is processed because of sharing this sub-plate with the H/HC Type Pressure Control Valve and not used for the Pressure Reducing (and Check) Valve.

Sub-plate Model Numbers	Thread Size		
	"A" Thd.	"B" Thd.	"C" Thd.
HGM-03-20	Rc 3/8	Rc 1/4	M10
HGM-03X-20	Rc 1/2		
HGM-03-2080	3/8 BSP.F	1/4 BSP.F	
HGM-03X-2080	1/2 BSP.F		
HGM-03-2090	3/8 NPT	1/4 NPT	3/8-16 UNC
HGM-03X-2090	1/2 NPT		

● HGM-06-20/2080/2090

DIMENSIONS IN MILLIMETRES (INCHES)

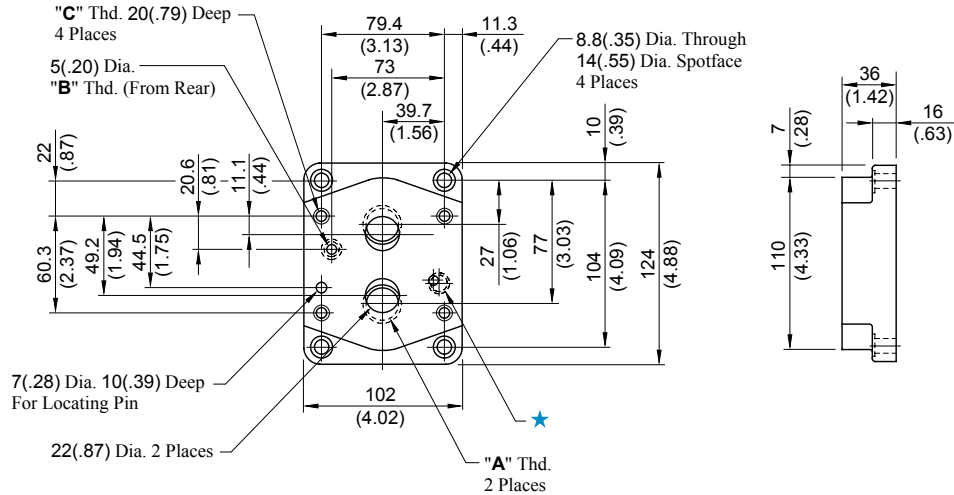

● HGM-06X-20/2080/2090

★ This part is processed because of sharing this sub-plate with the H/HC Type Pressure Control Valve and not used for the Pressure Reducing (and Check) Valve.

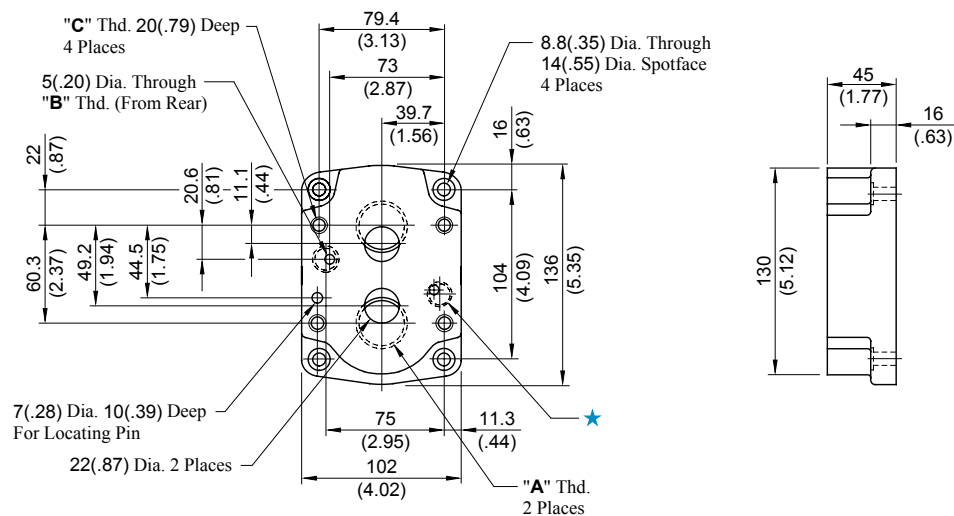

Sub-plate Model Numbers	Thread Size		
	"A" Thd.	"B" Thd.	"C" Thd.
HGM-06-20	Rc 3/4	Rc 1/4	M10
HGM-06X-20	Rc 1		
HGM-06-2080	3/4 BSP.F	1/4 BSP.F	
HGM-06X-2080	1 BSP.F		
HGM-06-2090	3/4 NPT	1/4 NPT	3/8-16 UNC
HGM-06X-2090	1 NPT		

● HGM-10-20/2080/2090

DIMENSIONS IN
MILLIMETRES (INCHES)

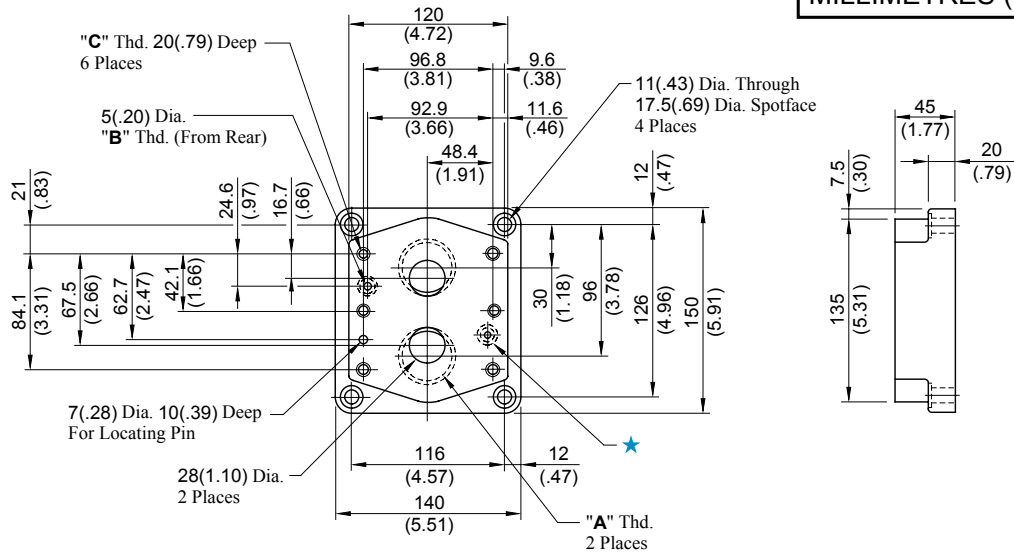

● HGM-10X-20/2080/2090

★ This port is processed because of sharing this sub-plate with the H/HC Type Pressure Control Valve and not used for the Pressure Reducing (and Check) Valve.

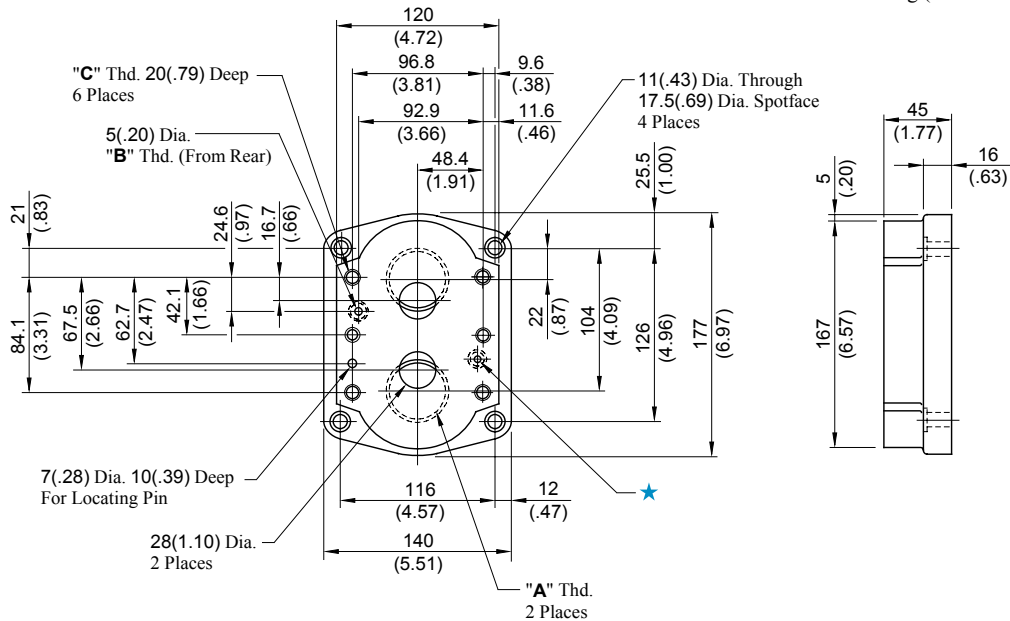

Sub-plate Model Numbers	Thread Size		
	"A" Thd.	"B" Thd.	"C" Thd.
HGM-10-20	Rc 1-1/4	Rc 1/4	M10
HGM-10X-20	Rc 1-1/2		
HGM-10-2080	1-1/4 BSP.F	1/4 BSP.F	
HGM-10X-2080	1-1/2 BSP.F		
HGM-10-2090	1-1/4 NPT	1/4 NPT	3/8-16 UNC
HGM-10X-2090	1-1/2 NPT		

■ Pressure Drop for Reversed Free Flow

Hydraulic Fluid: Viscosity 35 mm²/s (164 SSU), Specific Gravity 0.850

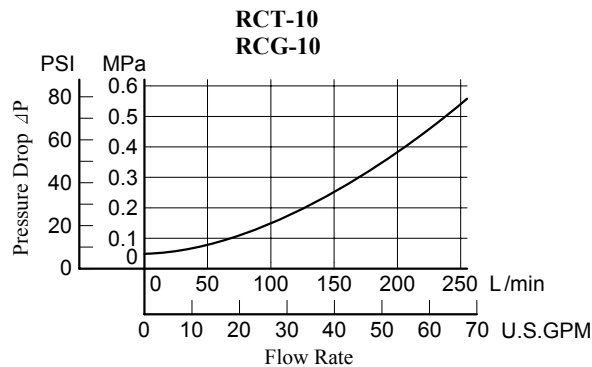
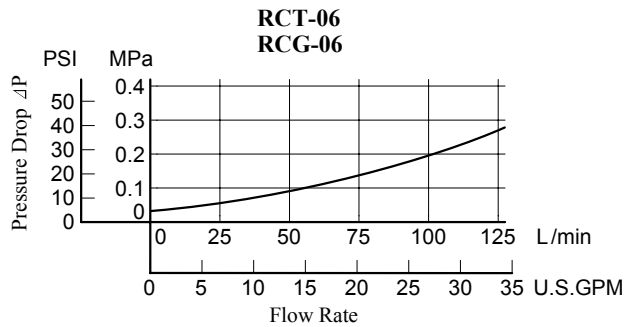
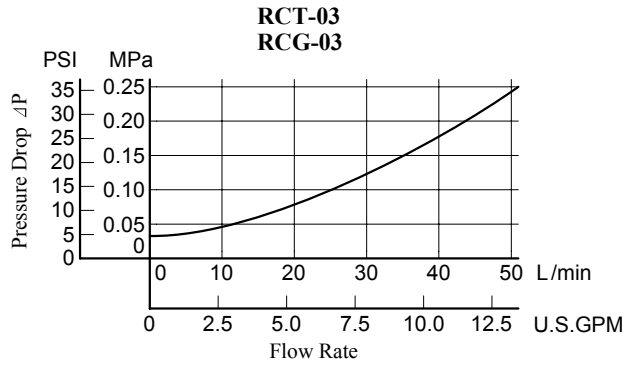

- For any other viscosity, multiply the factors in the table below.

Viscosity	mm ² /s	15	20	30	40	50	60	70	80	90	100
	SSU		77	98	141	186	232	278	324	371	417
Factor		0.81	0.87	0.96	1.03	1.09	1.14	1.19	1.23	1.27	1.30

- For any other specific gravity (G'), the pressure drop (ΔP') may be obtained from the formula below.

$$\Delta P' = \Delta P (G'/0.850)$$



RT/RG-03-*-22/2280/2290
RT/RG-06-*-22/2280/2290
RT/RG-10-*-22/2280/2290

⚠ CAUTION

When making replacement of seals, please do it carefully after reading through the relevant instructions in the Operator's Manual.

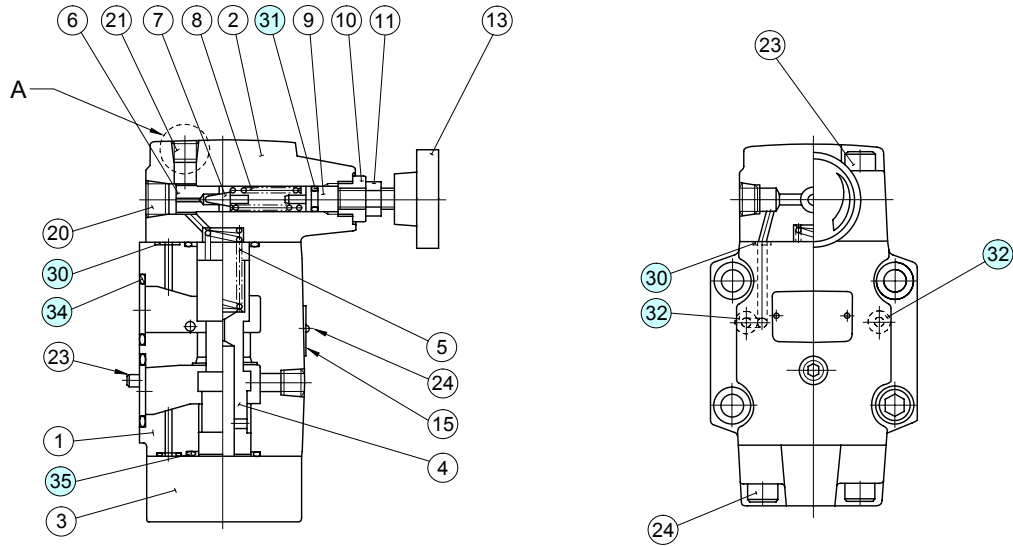

● List of Seals

Item	Name of Parts	Part Numbers			Quantity	
		RT -03 RG	RT -06 RG	RT -10 RG	RT-*	RG-*
30	O-Ring	SO-NB-P6	SO-NB-P6	SO-NB-P6	4	4
31	O-Ring	SO-NA-P9	SO-NA-P9	SO-NA-P9	1	1
32	O-Ring	SO-NB-P9	SO-NB-P9	SO-NB-P9	—	2
34	O-Ring	SO-NB-P18	SO-NB-P28	SO-NB-P32	—	2
35	O-Ring	SO-NB-P22	SO-NB-P28	SO-NB-P36	2	2
37	Bonded Seal	SG-FB-1/4	SG-FB-1/4	SG-FB-1/4	1	1

Note: When ordering the seals, please specify the seal kit number from the table below.

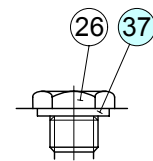

Section "A" for
Design 2280

● List of Seal Kits

Model Numbers	Seal Kit Numbers
RT-03-*-22/2280/2290	KS-RT-03-22
RT-06-*-22/2280/2290	KS-RT-06-22
RT-10-*-22/2280/2290	KS-RT-10-22
RG-03-*-22/2280/2290	KS-RG-03-22
RG-06-*-22/2280/2290	KS-RG-06-22
RG-10-*-22/2280/2290	KS-RG-10-22

Note: No bonded seals are included in the seal kits.

RCT/RCG-03-*22/2280/2290
 RCT/RCG-06-*22/2280/2290
 RCT/RCG-10-*22/2280/2290

⚠ CAUTION

When making replacement of seals, please do it carefully after reading through the relevant instructions in the Operator's Manual.

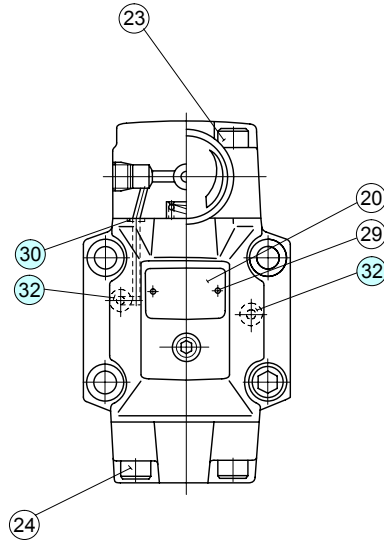
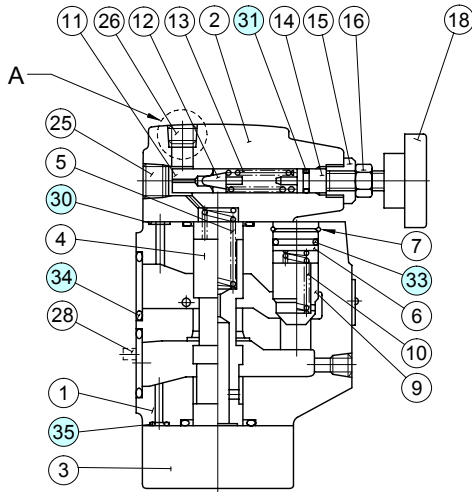

● List of Seals

Item	Name of Parts	Part Numbers			Quantity	
		RCT RCG-03	RCT RCG-06	RCT RCG-10	RCT-* RCG-*	RCT-* RCG-*
30	O-Ring	SO-NB-P6	SO-NB-P6	SO-NB-P6	4	4
31	O-Ring	SO-NA-P9	SO-NA-P9	SO-NA-P9	1	1
32	O-Ring	SO-NB-P9	SO-NB-P9	SO-NB-P9	—	2
33	O-Ring	SO-NB-P12	SO-NB-P18	SO-NB-P22A	1	1
34	O-Ring	SO-NB-P18	SO-NB-P28	SO-NB-P32	—	2
35	O-Ring	SO-NB-P22	SO-NB-P28	SO-NB-P36	2	2
37	Bonded Seal	SG-FB-1/4	SG-FB-1/4	SG-FB-1/4	1	1

Note: When ordering the seals, please specify the seal kit number from the table below.

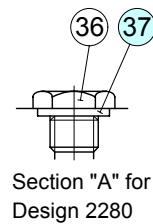

● List of Seal Kits

Model Numbers	Seal Kit Numbers
RCT-03-*22/2280/2290	KS-RCT-03-22
RCT-06-*22/2280/2290	KS-RCT-06-22
RCT-10-*22/2280/2290	KS-RCT-10-22
RCG-03-*22/2280/2290	KS-RCG-03-22
RCG-06-*22/2280/2290	KS-RCG-06-22
RCG-10-*22/2280/2290	KS-RCG-10-22

Note: No bonded seals are included in the seal kits.

