



"PV11R" SERIES

Fixed Displacement- Single

PV11R10/PV11R20

VANE PUMPS

Up to 40 MPa (5800 PSI), 22.1 cm³/rev (1.349 CU.IN./rev)

B

These pumps are of completely unique design for extra high pressure applications. The excessive wear to the vanes and camring which usually occurs in shch high pressure vane pumps has been solved by means of adopting the special methods in both mechanical construction aspects and lubrication systems.

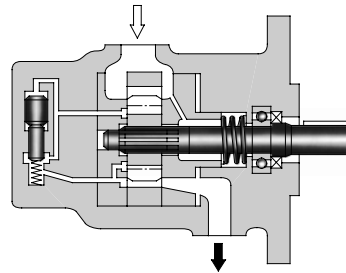
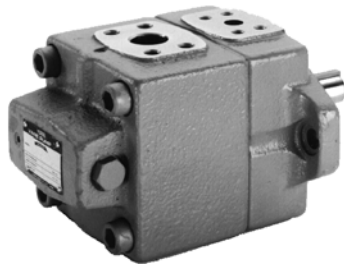

Graphic Symbol

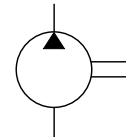

Model Number Designation

F-	PV11R10	-12	-L	-R	A	A	-20	*
Special Seals	Series Number	Nominal Displacement cm ³ /rev	Mounting	Direction of Rotation	Discharge Port Position	Suction Port Position	Design Number	Design Std.
F: For phosphate ester type fluids (Omit if not required)	PV11R10	2 5 7 10 12	L: Foot Mtg. F: Flange Mtg.	(Viewed from Shaft End) R: *1 Clockwise	A: Upwards (Normal)	A: Upwards (Normal)	20	Refer to *2
	PV11R20	15 19 22					20	

*1. Available to supply pump with anti-clockwise rotation. Consult Yuken for details.

*2. Design Standards: None.....Japanese Standard "JIS" & European Design Standard 90.....N. American Design Sandard

Pipe Flange Kits

Pipe flange kits are available. When ordering, specify the kit number from the table below.

Pump Model Numbers	Name of Port	Pipe Flange Kit Numbers						
		Threaded Connection			Socket Welding		Butt Welding	
		Japanese Standard "JIS"	European Design Standard	N. American Design Standard	Japanese Standard "JIS" European Design Standard	N. American Design Standard	Japanese Standard "JIS" European Design Standard	N. American Design Standard
PV11R10	Suction	F5-08-A-10	F5-08-A-1080	F5-08-A-1090	F5-08-B-10	F5-08-B-1090	F5-08-C-10	F5-08-C-1090
PV11R20	Discharge	—	—	—	F6-04W-B-M-10	F6-04W-B-U-1090	—	—

Note: 1) Special seals (Viton seals) are required when phosphate ester type fluids are used (prefix "F-" to the pipe flange kit number when ordering.).

Note: 2) Details specifications of pipe flange kits are given in the Catalogue No. Pub. EC-3001.

■ Specifications

● Maximum Operating Pressure

Model Numbers	Geometric Displacement cm ³ /rev (CU.IN./rev)	Maximum Operating Pressure MPa(PSI)					
		Petroleum Base Oils		Water Containing Fluids			Synthetic Fluids
		Anti-Wear Type	R & O Type	Anti-Wear ^{*1} Type Water Glycols	Water Glycols	Water in Oil Emulsions	Phosphate Esters
PV11R10-2	2.2 (.134)	31.5 (4570) ^{*2}	25 (3630)	25 (3630)	7 (1020)	7 (1020)	25 (3630)
PV11R10-5	4.5 (.275)						
PV11R10-7	6.8 (.415)						
PV11R10-10	9.7 (.592)						
PV11R10-12	12.1 (.738)						
PV11R20-15	15.2 (.915)	35 (5100)	25 (3630)	25 (3630)	7 (1020)	7 (1020)	25 (3630)
PV11R20-19	19.0 (1.159)						
PV11R20-22	22.1 (1.349)						

★1. For the brands of anti-wear type water-glycols, see the item of "Hydraulic Fluids" on page 3.

★2. For pressures above 25 MPa (3630 PSI), hold the speed above 1450 r/min.

● Shaft Speed Range

Model Numbers	Shaft Speed Range r/min				
	Max.				Min.
	Petroleum Base Oils		Water-Containing Fluids	Synthetic Fluids	
Anti-Wear Type	R & O Type	Phosphate Esters			
PV11R10-2	3000	1800	1200	1200	950*
PV11R10-5					
PV11R10-7					
PV11R10-10					
PV11R10-12	2000				800*
PV11R20-*	1800	1800	1200	1200	800*

★ For starting at low speed, the maximum viscosity is limited. For details, see the item of "Hydraulic Fluids" on page 3.

● Mass

Model Numbers	Approx. Mass kg(lbs.)	
	Flange Mtg.	Foot Mtg.
PV11R10	16.4 (36.2)	19.4 (42.8)
PV11R20	16.4 (36.2)	19.4 (42.8)

● Output Flow & Input Power

Characteristics are described on the pages as shown on the table below. Please see the pages concerned.

Model Numbers	Typical Pump Characteristics described on the Pages below
PV11R10	5, 6
PV11R20	6

■ Hydraulic Fluids

1. Type of hydraulic fluids

Any type of hydraulic fluids listed in the Table 1 below can be used. However, the specifications of the pumps such as maximum pressure and maximum pump speed may be changed according to the type of hydraulic fluids to be used. For details, please refer to the specifications of the pump concerned.

● Type of hydraulic fluids (Table 1)

Type of Fluids		Descriptions
Petroleum Base Oils		Use anti-wear type oils or R&O type oils (equivalent to ISO VG32 or 46).
Synthetic Fluids		Use phosphate ester type fluids. When phosphate ester type fluid is used, prefix "F-" to the model number because the special seals (fluororubber) are required to be used.
Water Containing Fluids	Water-Glycols	Standard pumps can be used without conditions. However, if any type other than those in Table 2 is used, the maximum operating pressure is limited.
	Water in Oil Emulsions	Standard pumps can be used without conditions.

● Anti-wear type water-glycols (Table 2)

Fluid Manufacturer	Commercial Trade Name
Mobil	Mobil Hydrofluid HFC 46 Mobil Nybac FR 200 D
JAPAN ENERGY CORP.	JOMO Hydoria
NIPPON OIL CO., LTD	HYRAND FRX 46
Showa Shell Sekiyu K. K.	Irus Fluid C G-W Fluid 46
MATSUMURA OIL RESEARCH CORP.	HYDOL HAW
COSMO OIL CO., LTD.	COSMO FLUID HQ 46 COSMO FLUID GS 46

2. Fluid viscosity and temperature

Use the hydraulic fluids which satisfy the recommended viscosity and oil temperature given in the Table 3 below. However, please note that if any of the pumps listed in the Table 4 is started at low speed, the maximum fluid viscosity is limited.

● Fluid viscosity and temperature (Table 3)

Fluid	Temperature °C (°F)	Viscosity mm ² /s(SSU)
Petroleum Base Oils	0-70 (32-158)	20-400 (100-1800)
Phosphate Esters		
Water Glycols	0-50 (32-122)	
Water in Oil Emulsions	5-50 (41-122)	

● Maximum viscosity for low start-up speed (Table 4)

Pump Type	Start-up Speed r/min	Max. Viscosity mm ² /s (SSU)
PV11R10, PV11R20	600	100 (455)
	950	200 (910)

3. Control of contamination

Contamination of hydraulic fluids results in pump failures and reduced pump lives. Carry out sufficient contamination control for hydraulic fluids and keep contamination level within NAS class 12.

Also, use a 100 μm (150-mesh) tank filter on the suction side, more than 50 mm (2 in.) away from the tank bottom.

■ Instructions

1. Alignment of shaft

Employ a flexible coupling whenever possible, and avoid any stress from bending or thrust.

Maximum permissible misalignment is less than 0.1 mm (.004 inches) TIR and maximum permissible misangular is less than 0.2°.

2. Suction pressures

Set the suction pressure at pump inlet port at the value given in the table below. Furthermore, use the pipes in the suction side having the diameter as indicated on the installation drawings. In case where the pump is installed on the tank or at the position higher than the tank top cover, the height of the suction port of the pump should be less than 1 metre (3.3 ft.) from the oil level {less than 0.8 metre (2.6 ft.) in case of using phosphate ester fluids or water containing fluids}.

(Table 5)

Model Numbers	Suction Pressure		
	Minimum		Maximum
	Petroleum base oil	Phosphate ester type fluid water containing fluid	
PV11R, PV11R20	-20 kPa (5.9 in. Hg Vacuum)	-16 kPa (4.7 in. Hg Vacuum)	+30 kPa (+4.3 PSIG)

3. Precautions at starting

At an initial operation or at an operation after a long rest, the pump may have difficulty in sucking up fluid. In such cases, an air bleed valve should be installed beforehand on the discharge side (model No. ST1004-*-10*, Catalogue No. Pub. EC-3001.), or discharge air by slightly slackening the connection on the discharge side. At starting, operate the pump intermittently as far as possible with no load.

For fluid viscosity at starting, see the item of "Hydraulic Fluids".

4. Other precautions

If a PV11R series single pump is used at speed below 1200 r/min, install the pump with the suction port upside so that the pump can suck up fluid easily at starting.

Flange Mtg.

PV11R10-**-F-RAA-20/2090

PV11R20-**-F-RAA-20/2090

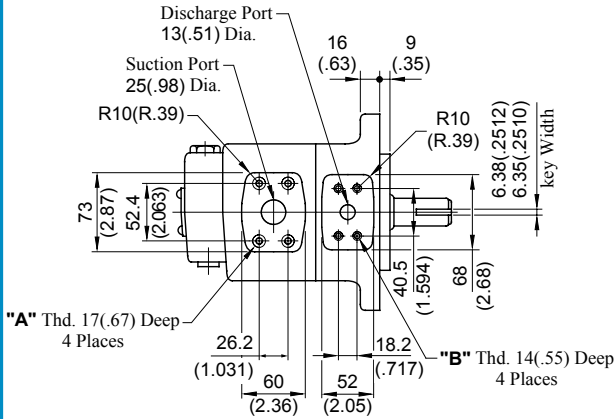

Model Numbers	"A" Thd.	"B" Thd.
PV11R10/PV11R20-**-RAA-20	M10	M8
PV11R10/PV11R20-**-RAA-2090	3/8-16 UNC	5/16-18 UNC

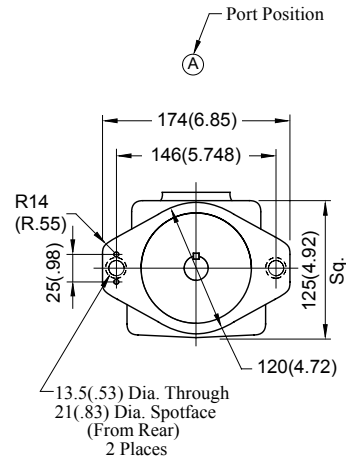
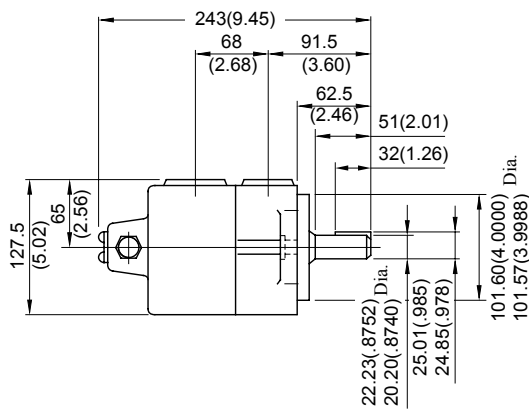

DIMENSIONS IN MILLIMETRES (INCHES)

Foot Mtg.

PV11R10-**-L-RAA-20/2090

PV11R20-**-L-RAA-20/2090

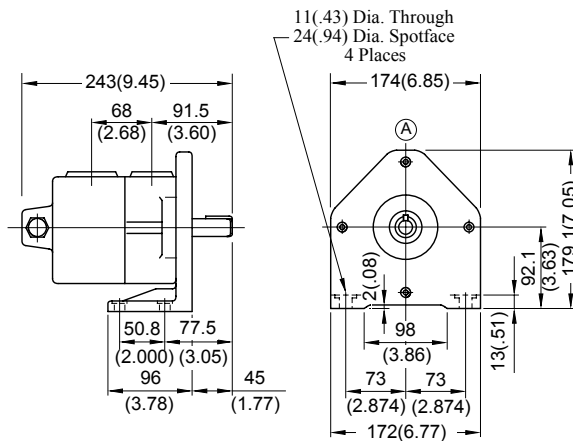

• For other dimensions, refer to "Flange Mtg.".

Viscosity 20 mm²/s (100 SSU) [ISO VG32 Oils, 50°C (122°F)]

● PV11R10-2

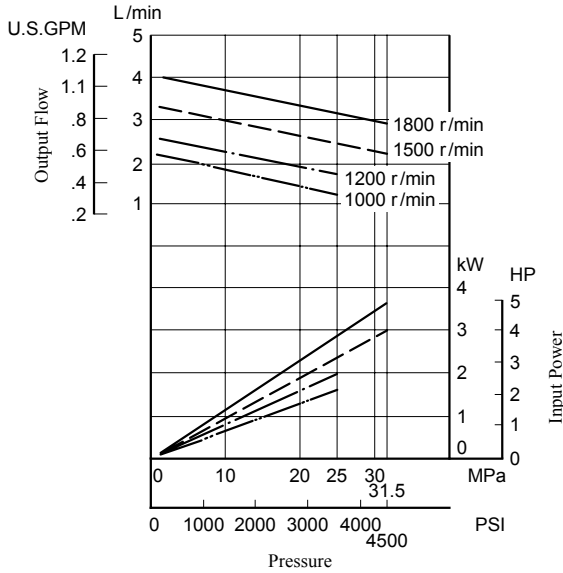

● PV11R10-5

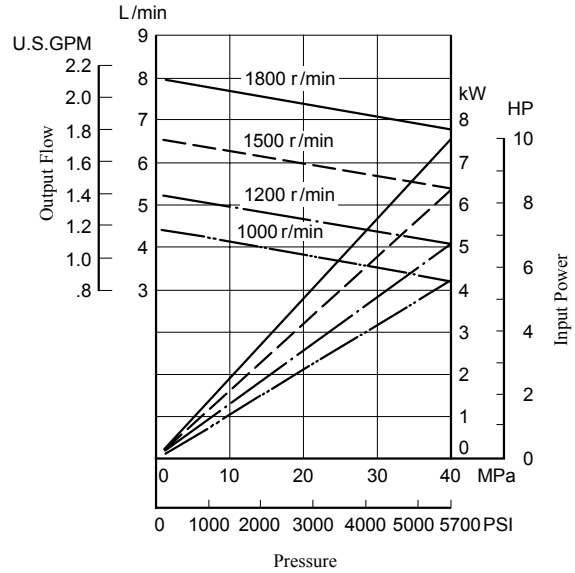

● PV11R10-7

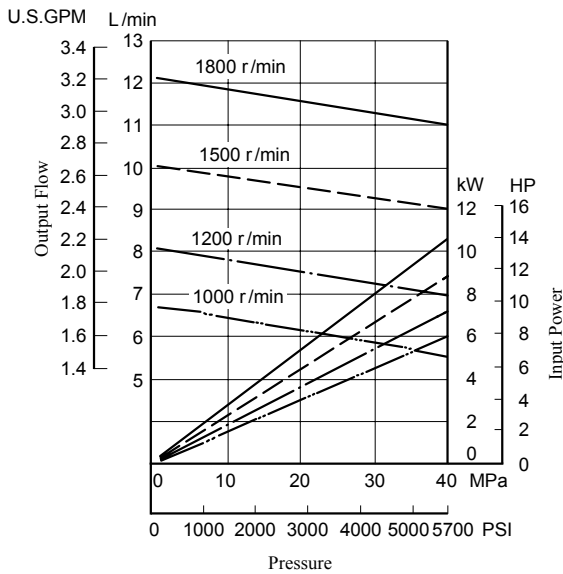

● PV11R10-10

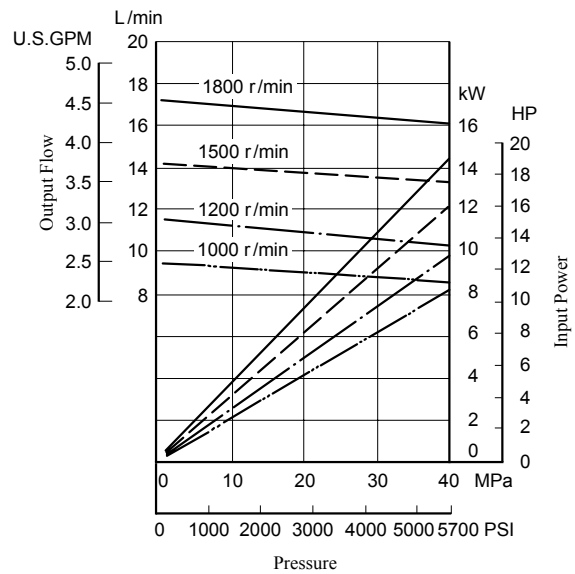

Viscosity 20 mm²/s (100 SSU) [ISO VG32 Oils, 50°C (122°F)]

● PV11R10-12

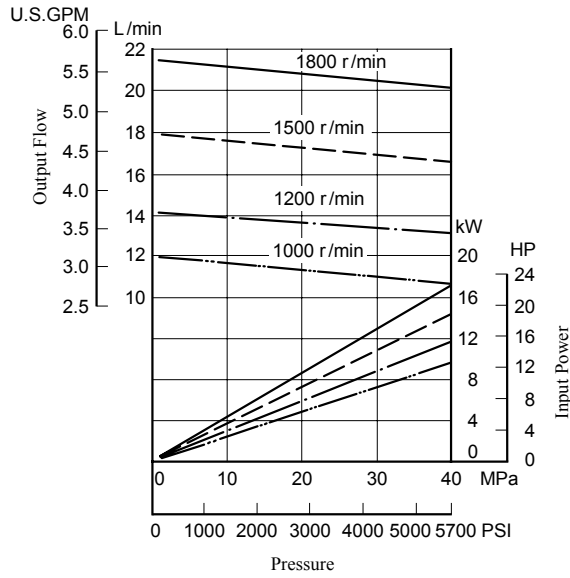

● PV11R20-15

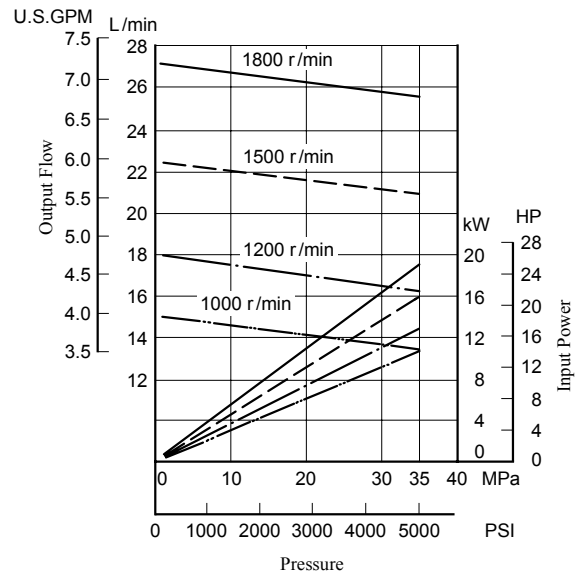

● PV11R20-19

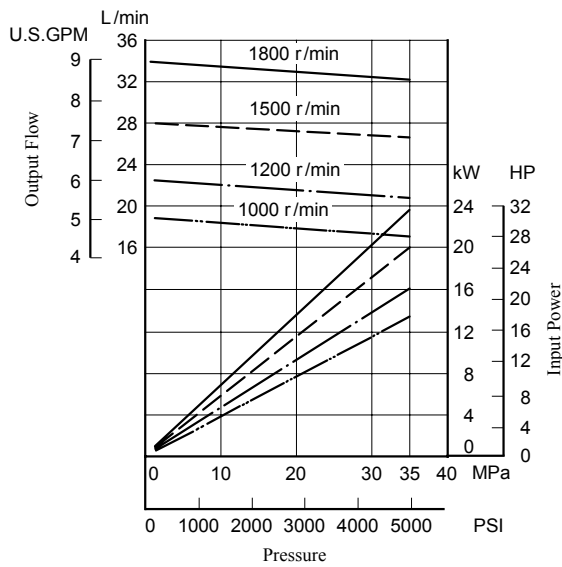

● PV11R20-22

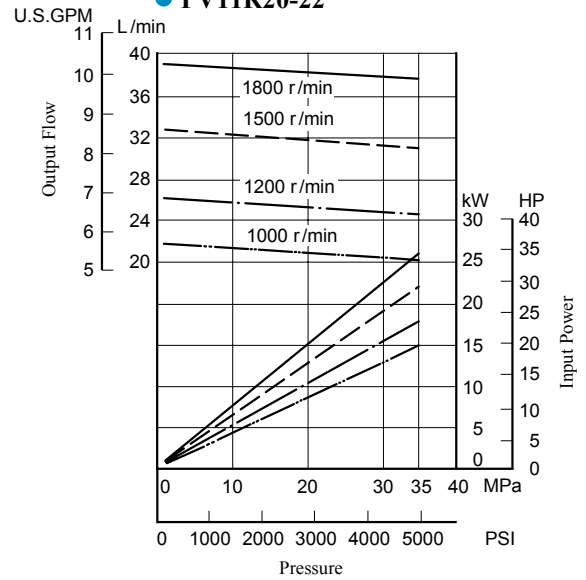

PV11R10-*-**-RAA-20/2090
PV11R20-*-**-RAA-20/2090

⚠ CAUTION

When making replacement of seals, bearings or cartridge kits, please do it carefully after reading through the relevant instructions in the Operator's Manual.

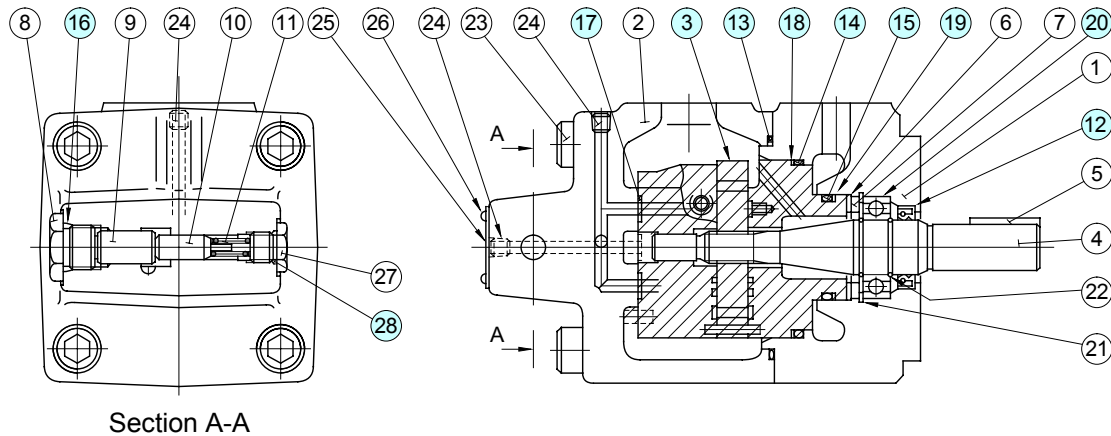

● Cartridge Kits

Model Numbers	③ Cartridge Kit No.
PV11R10-2-*-**-RAA-20/2090	CPV11R10-2-R-20
PV11R10-5-*-**-RAA-20/2090	CPV11R10-5-R-20
PV11R10-7-*-**-RAA-20/2090	CPV11R10-7-R-20
PV11R10-10-*-**-RAA-20/2090	CPV11R10-10-R-20
PV11R10-12-*-**-RAA-20/2090	CPV11R10-12-R-20
PV11R20-15-*-**-RAA-20/2090	CPV11R20-15-R-20
PV11R20-19-*-**-RAA-20/2090	CPV11R20-19-R-20
PV11R20-22-*-**-RAA-20/2090	CPV11R20-22-R-20

● Seals & Bearing

Item	Name of Parts	Part Numbers	Qty.
		PV11R10, PV11R20	
12*	Oil Seal	ISD 25 38 8	1
13*	O-Ring	SO-NB-G95	1
14*	O-Ring	SO-NB-G75	1
15*	O-Ring	SO-NB-P42	1
16*	O-Ring	SO-NB-P18	1
17*	O-Ring	SO-NB-P9	3
18*	Back Up Ring	SO-BE-G75	1
19*	Back Up Ring	SO-BB-P42	1
20	Bearing	6005	1
28*	O-Ring	SO-NB-P11	1

Notes: 1) Item Nos. ⑭, ⑮ and ⑰ (o-rings) and ⑱ and ⑲ (back up rings) are included in the cartridge kit.

2) For pumps for phosphate ester type hydraulic fluids, different cartridge kit and seals from the above are used. Please contact us.

★ When ordering seals, please specify the seal kit number (Kit No.: KS-PV11R10-20).