



"AH" SERIES PISTON PUMPS
Variable Displacement-Single Pumps
Pressure Compensator Type
AH 16 / AH 37 / AH 56

PISTON PUMPS

A

Up to 31 MPa (4500 PSI), 56.2 cm³/rev (3.43 CU.IN./rev)

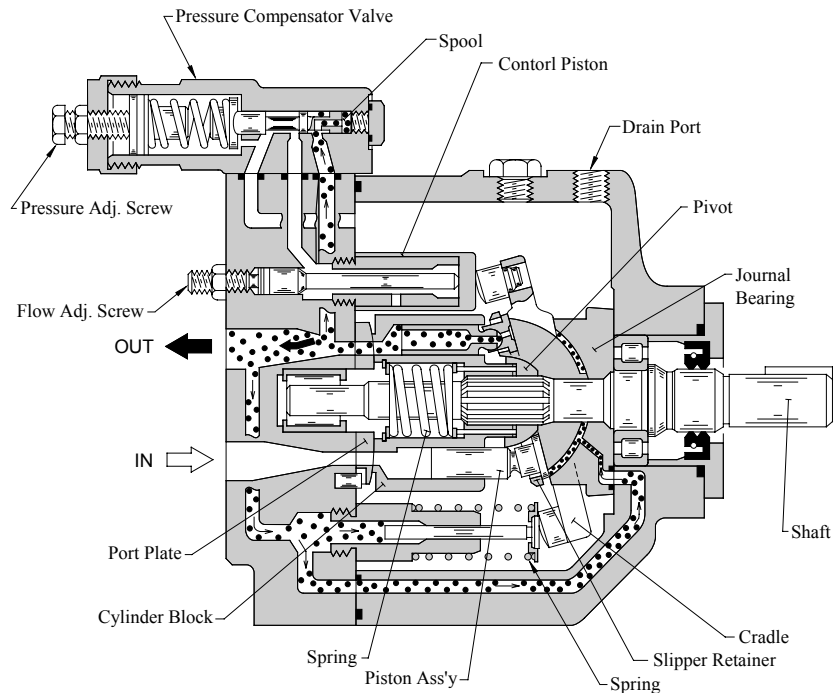

Features

Port Plate

A special shape maintains a high volumetric efficiency under high pressure and provides greater durability.

Cradle Support Bearing

Compared with conventional bearings, this bearing has strengthened rigidity of the swash plate. Noise level has much lowered because it is supported by a housing.

"AH16" type performance characteristics

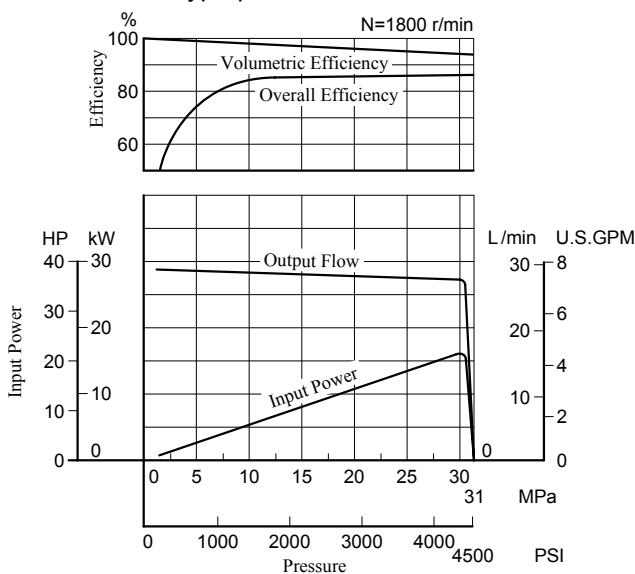

"AH16" type noise level characteristics

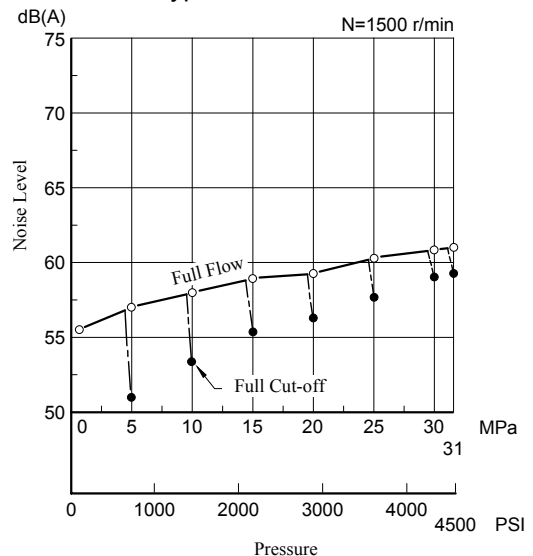

High Pressure

Max. Operating Pres. 31 MPa (4500 PSI)

High speed

Max. 3600 r/min (AH 16)

Instructions

1. Hydraulic Fluids

Use petroleum base oils such as anti-wear type hydraulic oils or R & O (Rust and Oxidation inhibitor) type hydraulic oils equivalent to ISO VG-32 or 46.

The recommended viscosity range is from 20 to 400 mm²/s (98 to 1800 SSU) and temperature range is from 0 to 60°C (32 to 140°F), both of which have to be satisfied for the use of the above hydraulic oils.

2. Control of Contamination

Due caution must be paid to maintaining control over contamination of the operating oil which can otherwise lead to breakdowns and shorten the life of the unit. Please maintain the degree of contamination within NAS Grade 10.

The suction port must be equipped with at least a 100 μm (150 mesh) reservoir type filter and the return line must have a line filter of under 10 μm.

3. Mounting

When installing the pump the filling port should be positioned upwards.

4. Alignment of Shaft

Employ a flexible coupling whenever possible, and avoid any stress from bending or thrust.

Maximum permissible misalignment is less than 0.1 mm (.0039 inches) TIR and maximum permissible misangular is less than 0.2°.

5. Suction Pressure

Permissible suction pressure at suction port of the pump is between -16.7 and +50 kPa (5 in.Hg Vacuum and 7 PSIG). In case of the speed is over 1800 r/min, adjust the pressure 0 to +50 kPa (0 to 7 PSIG).

For piping to the suction port, use the pipes of the same diameter as that of the specified pipe flange to be used.

Make sure that the height of the pump suction port is within one metre (3.3ft.) from the oil level in the reservoir.

6. Hints on Piping

When using steel pipes for the suction or discharge ports, excessive load from the piping to the pump generates excessive noise.

Whenever there is fear of excessive load, please use rubber hoses.

7. Suction Piping

In case the pump is installed above the oil level, the suction piping and suction line filter should be located lower than the pump position to prevent air in the suction line.

8. Drain Piping

Install drain piping according to the chart and ensure that pressure within the pump housing should be maintained at a normal pressure of less than 0.1 MPa (15 PSI) and surge pressure of less than 0.5 MPa (70 PSI).

Length of piping should be less than 1 m (3.3 ft.), and the pipe end should be submerged in oil.

[Recommended Drain Piping Size]

Model	Fitting Size	Inside Dia. of pipe
AH16 AH37	1/2 [Inside Dia. 12 mm (.47 in.) or more]	12 mm (.47 in.)
AH56	3/4 [Inside Dia. 16 mm (.63 in.) or more]	19 mm (.75 in.)

9. Bleeding Air

It may be necessary to bleed air from pump case and outlet line to remove causes of vibration. An air bleed valve (Model No. ST1004-*10*, Catalogue No.: Pub. EC-3001) is recommended for this purpose.

10. Starting

Before first starting, fill pump case with clean operating oil via the fill port.

In order to avoid air blockage when first starting, adjust the control valves so that the discharged oil from the pump is returned direct to the tank or the actuator moves in a free load.

[Volume of Pre-fill Oil Required]

Model	Volume cm ³ (in. ³)
AH16	600 (36.6)
AH37	1100 (67.1)
AH56	1500 (91.5)

11. Setting Discharge Pressure and Delivery

At the time of shipment, the unit has been preset to maximum delivery and minimum discharge pressure.

Adjust the preset delivery and pressure to meet your system requirements.

● **Adjustment of Discharge Pressure**

Turning the adjustment screw clockwise, increases pressure.

[Volume adjusted by each full turn of the pressure adjustment screw]

Model Numbers	Adjustment Volume MPa (PSI)
AH16/AH37/AH56	5.4 (780)

● **Adjustment of Delivery**

Turning the flow adjustment screw clockwise, decreases delivery.

[The minimum adjustable flow and adjustable volume of each full turn of the delivery adjustment screw]

Model Numbers	Adjustable volume with each full turn of the adjustment screw cm ³ /rev (cu.in./rev)	Minimum adjustable flow cm ³ /rev (cu.in./rev)
AH16	1.4 (.085)	8 (.488)
AH37	3.0 (.183)	14 (.854)
AH56	3.5 (.214)	35 (2.14)



Graphic Symbol

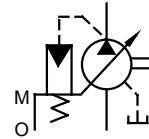

Specifications

Model Numbers	Geometric Displacement cm ³ /rev (cu. in./rev)	Minimum Adj. Flow cm ³ /rev (cu. in./rev)	Operating Pres. MPa (PSI)		Shaft Speed Range r/min		Approx. Mass kg (lbs.)	
			Rated [*]	Intermittent	Max.	Min.	Flang Mtg.	Foot Mtg.
AH16- <i>*R01K*-10*</i>	16.0 (.976)	8.0 (.488)	25 (3630)	31 (4500)	3600	600	18.8 (41.5)	23.8 (52.5)
AH37- <i>*R01K*-20*</i>	37.0 (2.26)	14.0 (.854)			2800	600	26.0 (57.3)	35.0 (77.2)
AH56- <i>*R01K*-11*</i>	56.2 (3.43)	35.0 (2.14)			2500	600	42.0 (92.6)	50.9 (112)

★ Consult Yuken when pump is used over rated pressure because there is a restriction on operating condition.

Model Number Designation

AH16	-F	R	01	K	K	-10	*
Series Number	Mounting	Direction of Rotation	Control Type	Pres Adj. Range MPa (PSI)	Shaft ^{*1} Extension	Design Number	Design Std.
AH16 (16.0 cm ³ /rev)	F: Flange Mtg. L: Foot Mtg.	R: Clockwise (Normal)	01: Pressure Compensator Type	K: 5 - 31 (730 - 4500)	K: Keyed Shaft	10	Refer to ^{*2}
AH37 (37.0 cm ³ /rev)						20	
AH56 (56.2 cm ³ /rev)						11	

★1. We can also supply spline-type shaft extension. Please consult us for details.

★2. Design Standards: None ... Japanese Standard "JIS"
80 European Design Standard
90 N. American Design Standard

Pipe Flange Kits

Pipe flange kits are available. When ordering, specify the kit number from the table below.

Pump Model Numbers	Name of Port	Pipe Flange Kit Numbers						
		Thread Connection			Socket Welding		Butt Welding	
		Japanese Standard "JIS"	European Design Standard	N. American Design Standard	Japanese standard "JIS" European Design Standard	N. American Design Standard	Japanese Standard "JIS" European Design Standard	N. American Design Standard
AH16	Suction	F5-08-A-10	F5-08-A-1080	F5-08-A-1090	F5-08-B-10	F5-08-B-1090	F5-08-C-10	F5-08-C-1090
	Discharge	F6-06-A-M-10	F6-06-A-M-1080	F6-06-A-U-1090	F6-06-B-M-10	F6-06-B-U-1090	—	—
AH37	Suction	F5-12-A-10	F5-12-A-1080	F5-12-A-1090	F5-12-B-10	F5-12-B-1090	F5-12-C-10	F5-12-C-1090
	Discharge	F6-10-A-M-10	F6-10-A-M-1080	F6-10-A-U-1090	F6-10-B-M-10	F6-10-B-U-1090	—	—
AH56	Suction	F5-16-A-10	F5-16-A-1080	F5-16-A-1090	F5-16-B-10	F5-16-B-1090	F5-16-C-10	F5-16-C-1090
	Discharge	F6-10-A-M-10 or F6-10W-A-M-10	F6-10-A-M-1080 or F6-10W-A-M-1080	F6-10-A-U-1090 or F6-10W-A-U-1090	F6-10-B-M-10 or F6-10W-B-M-10	F6-10-B-U-1090 or F6-10W-B-U-1090	—	—

● Detail of the pipe flange kits are given in the Catalogue No. Pub. EC-3001.

Response Characteristics

■ Response Characteristics

Response Characteristics Change in Accordance with Circuits and Operating Conditions.

● Test Circuit and Conditions

● Circuit

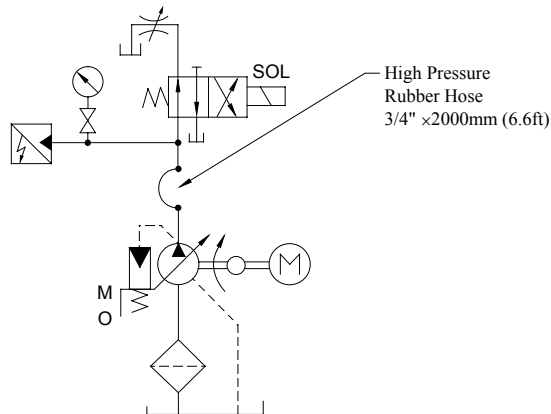

● Conditions

Drive Speed: 1500 r/min
 Hydraulic Fluid: ISO VG32 Oil
 Oil Temperature: 40°C (104°F) [Viscosity 32 mm²/s (150 SSU)]

● Result of Measurement

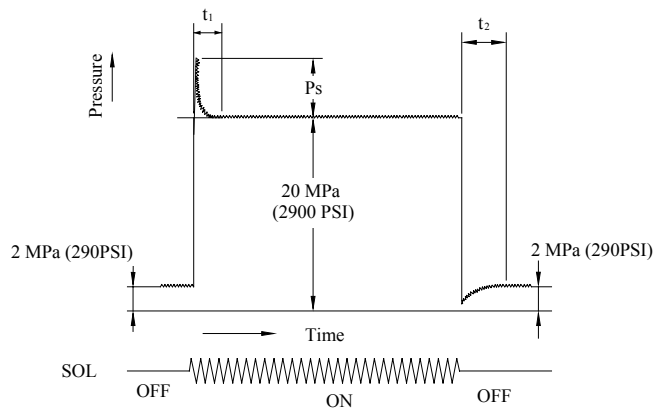

Model	Response Time ms		Ps Overshoot Pres. MPa (PSI)
	t ₁	t ₂	
AH16	50	95	2.5 (360)
AH37	60	150	5.1 (740)
AH56	60	115	8.3 (1200)

Typical Performance Characteristics of Type "AH16" at Viscosity 32 mm²/s (150 SSU) [ISO VG32 Oils, 40°C (104°F)]

■ Performance Characteristic Curve

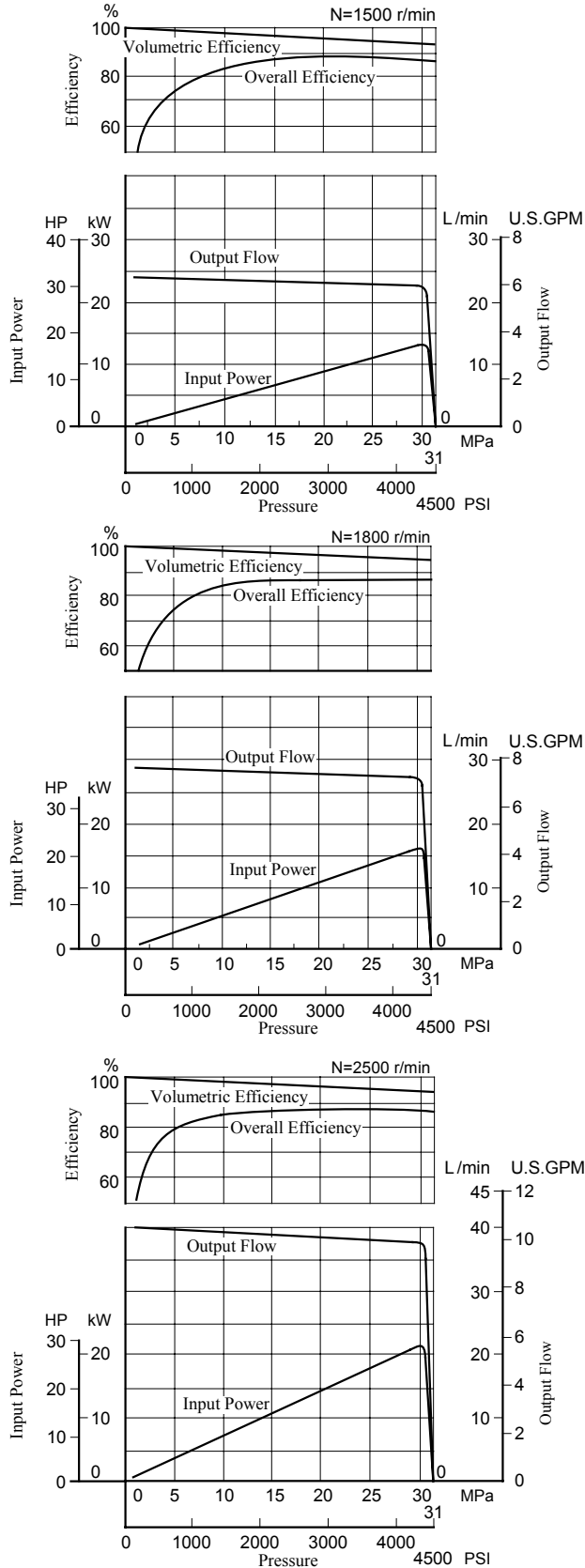

■ Input Power

Example: At a pressure of under 30 MPa (4350 PSI), a flow 15 L/min (4.0 U.S.GPM), and rotation 1500 r/min, the axial input becomes about 9 kW (12 HP) as shown the dotted line in the graph.

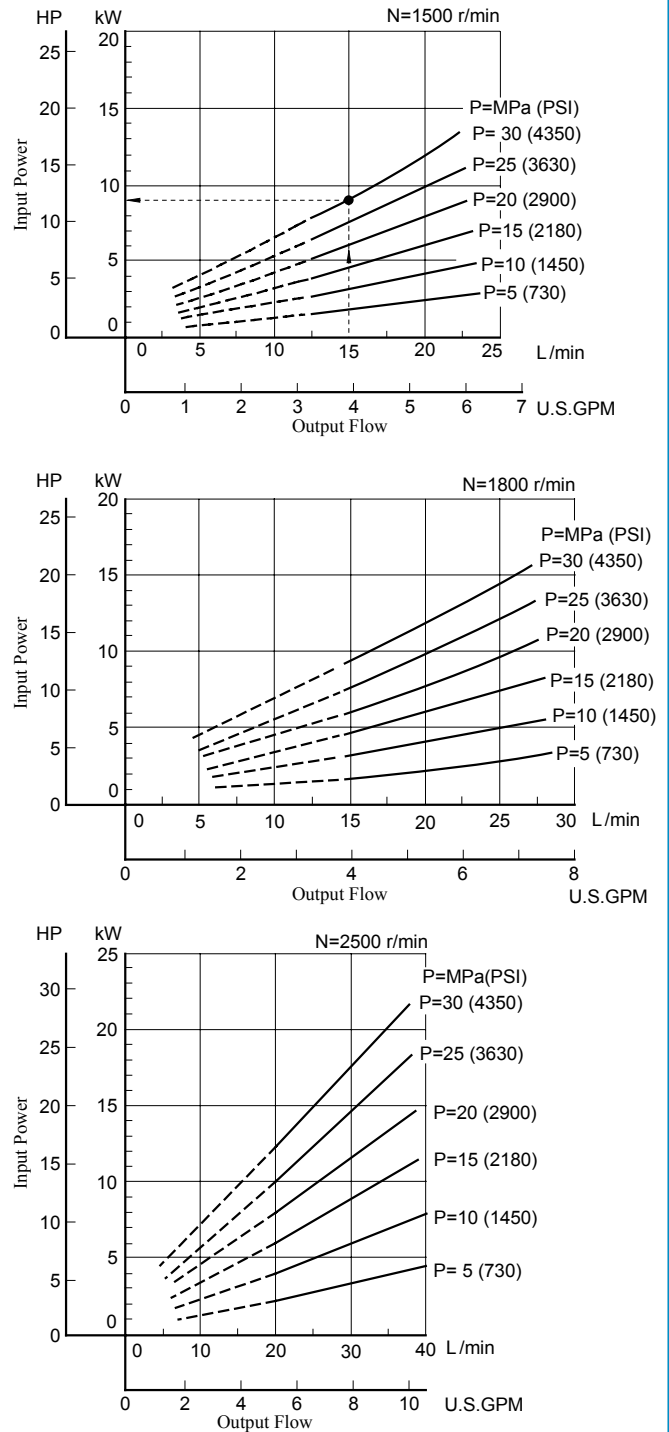

Note) The dotted line in the graph indicates less than minimum adjustable flow.

Typical Performance Characteristics of Type "AH16" at Viscosity 32 mm²/s (150 SSU) [ISO VG32 Oils, 40°C (104°F)]

■ Noise Level

[One metre (3.3 ft.) horizontally away from pump head cover]

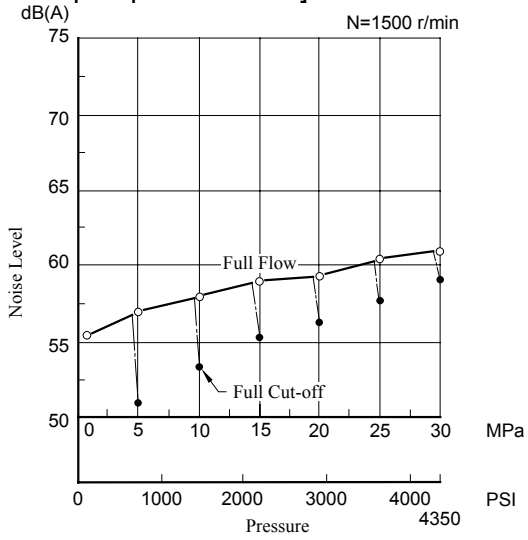

■ Full Cut-off Power

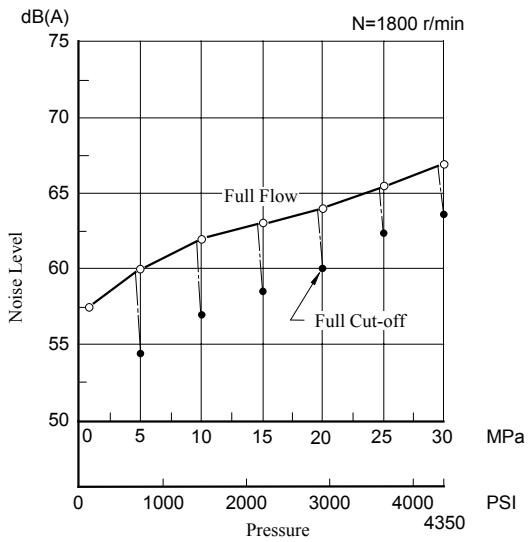
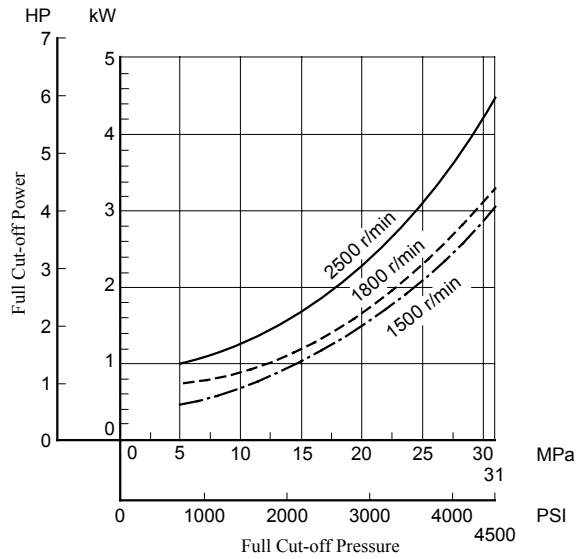

■ Drain

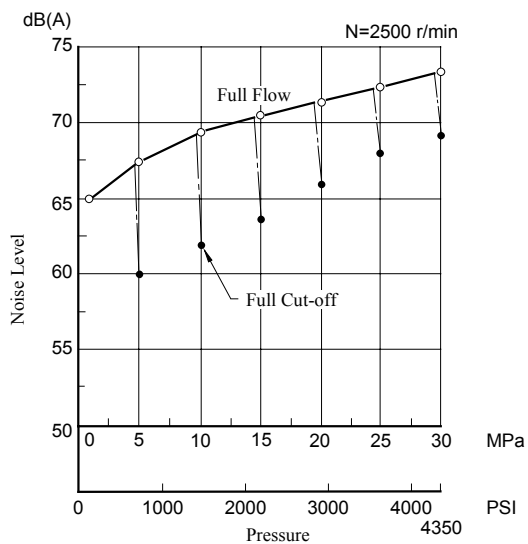
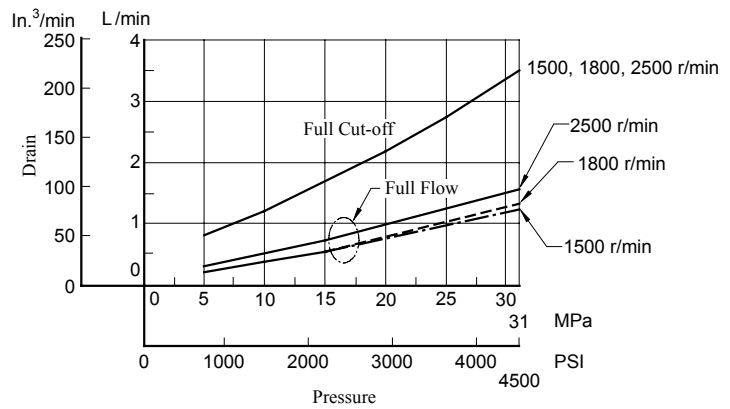

Typical Performance Characteristics of Type "AH37" at Viscosity 32 mm²/s (150 SSU) [ISO VG32 Oils, 40°C (104°F)]

Performance Characteristic Curve

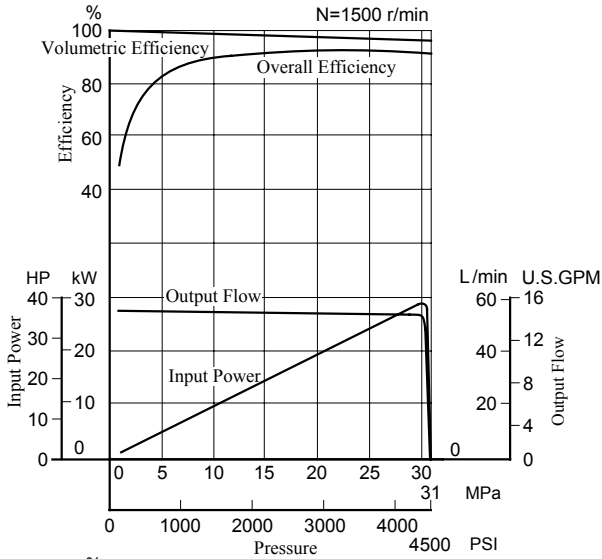

Input Power

Example: At a pressure of under 30 MPa (4350 PSI), a flow 35 L/min (9.2 U.S.GPM), and rotation 1500 r/min, the axial input becomes about 19 kW (25.5 HP) as shown the dotted line in the graph.

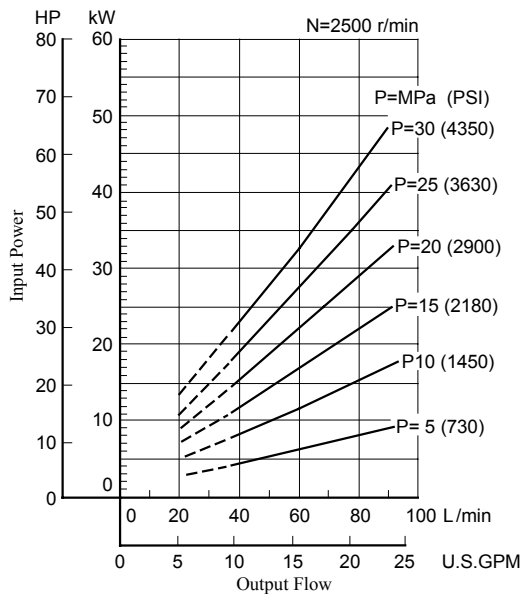
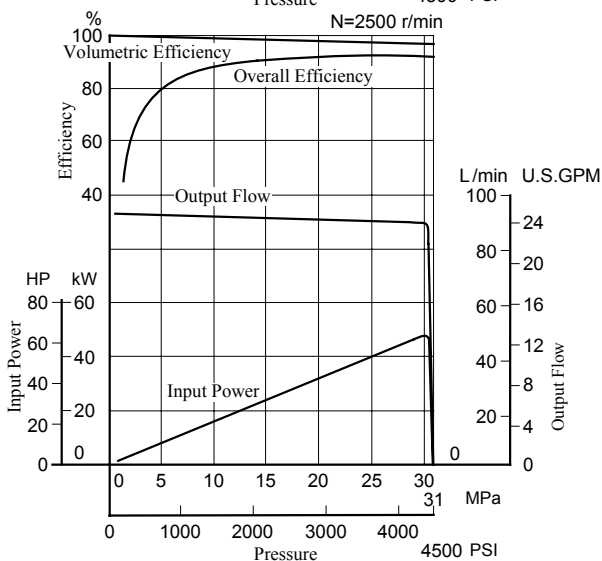
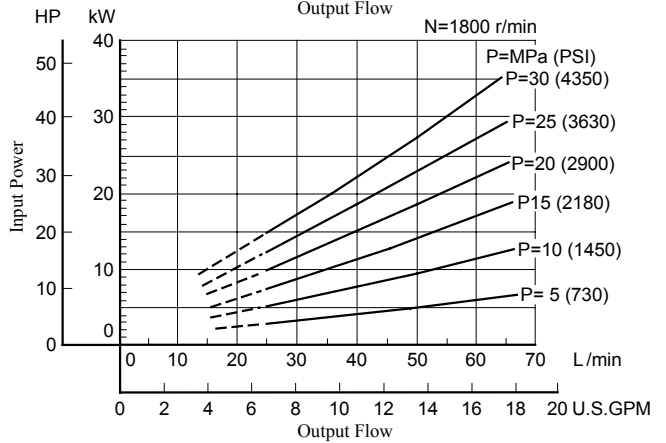
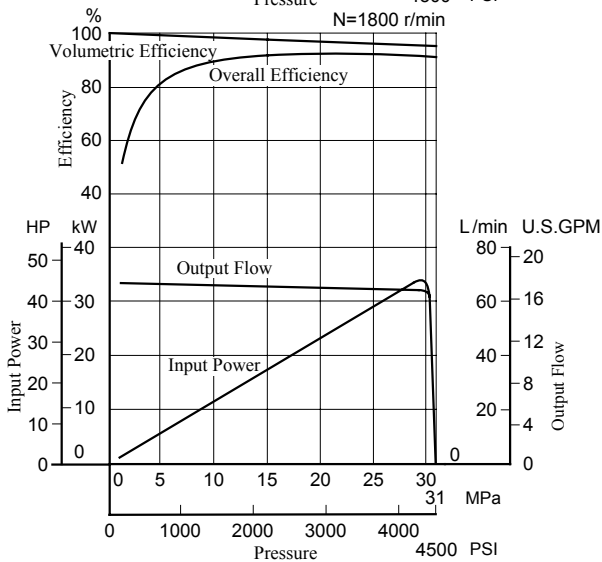
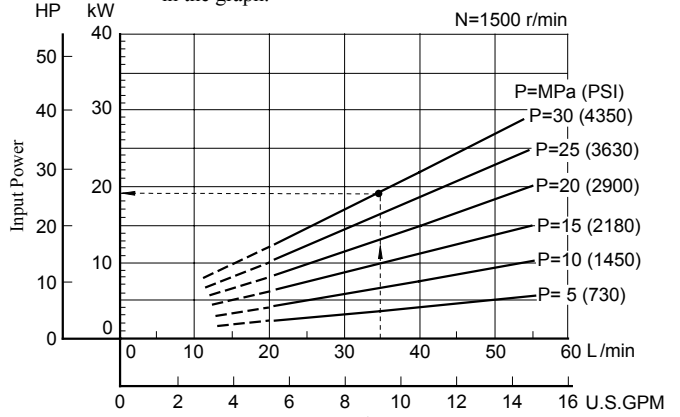

Note) The dotted line in the graph indicates less than minimum adjustable flow.

Typical Pump Characteristics

Typical Performance Characteristics of Type "AH37" at Viscosity 32 mm²/s (150 SSU) [ISO VG32 Oils, 40°C (104°F)]

■ Noise Level

[One metre (3.3 ft.) horizontally away from pump head cover]

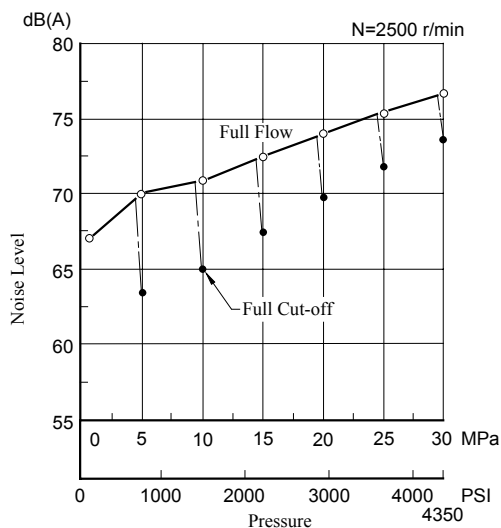
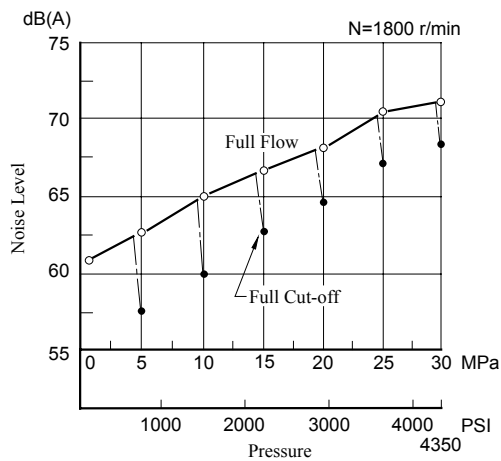
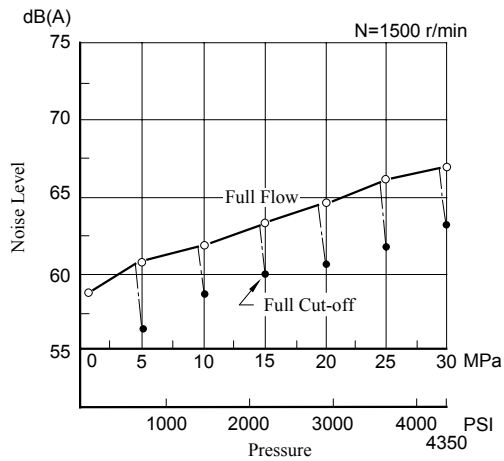

■ Full Cut-off Power

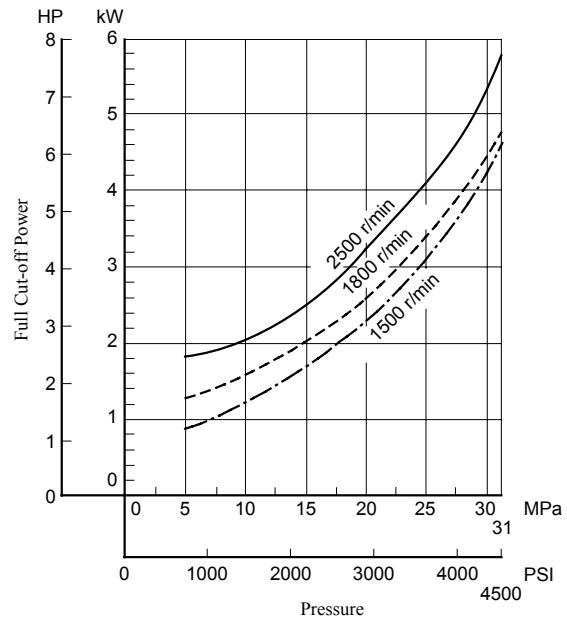

■ Drain

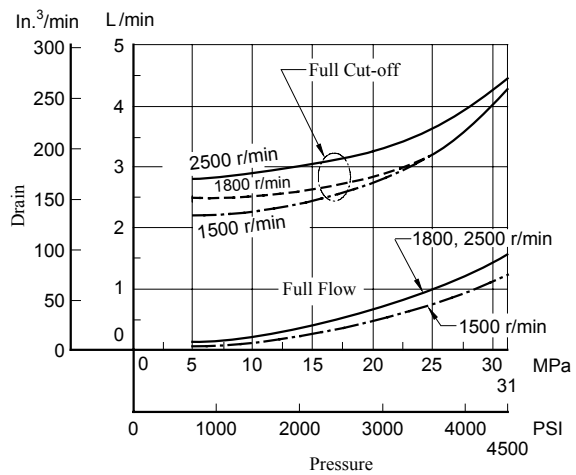

Typical Performance Characteristics of Type "AH56" at Viscosity 32 mm²/s (150 SSU) [ISO VG32 Oils, 40°C (104°F)]

■ Performance Characteristic Curve

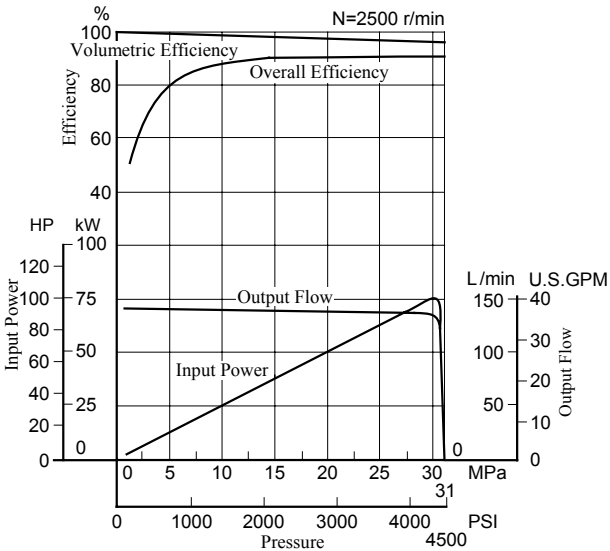
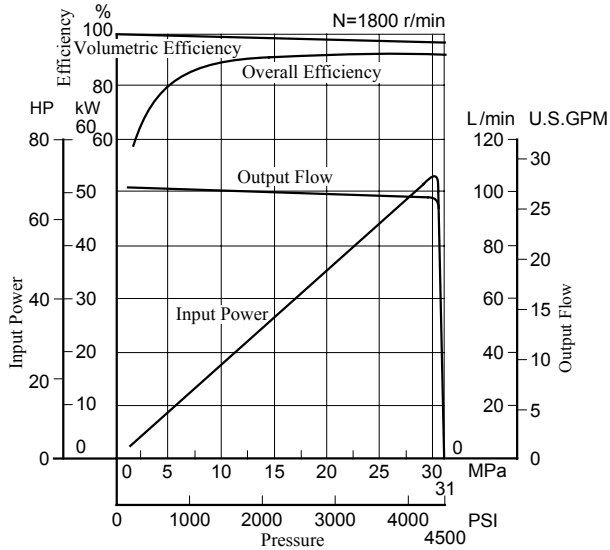
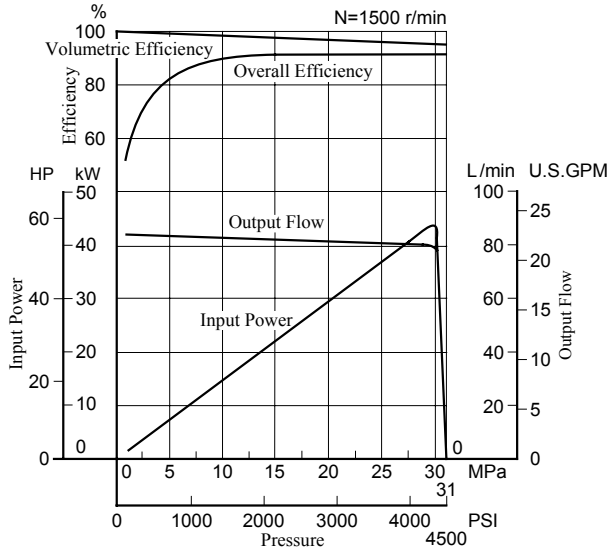

■ Input Power

Example: At a pressure of under 30 MPa (4350 PSI), a flow 65 L/min (17.2 U.S.GPM), and rotation 1500 r/min, the axial input becomes about 36 kW (48 HP) as shown the dotted line in the graph.

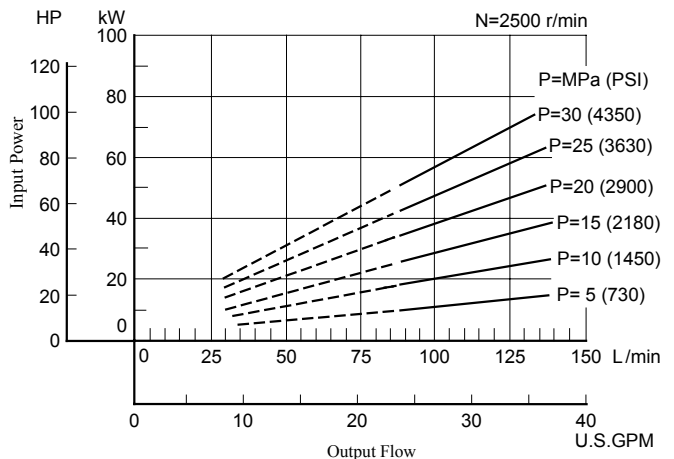
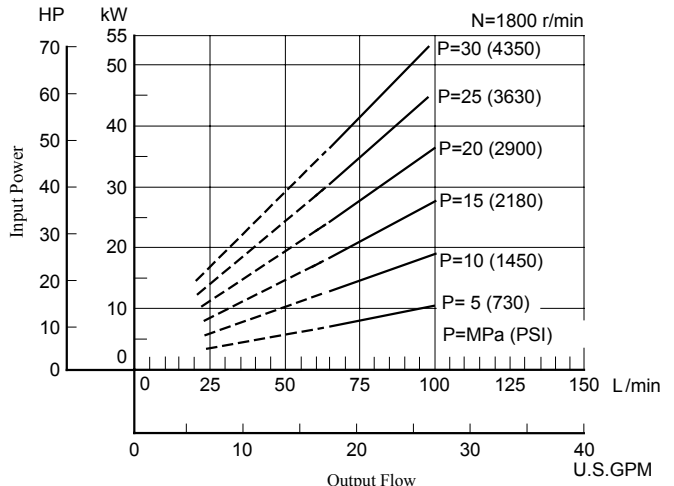
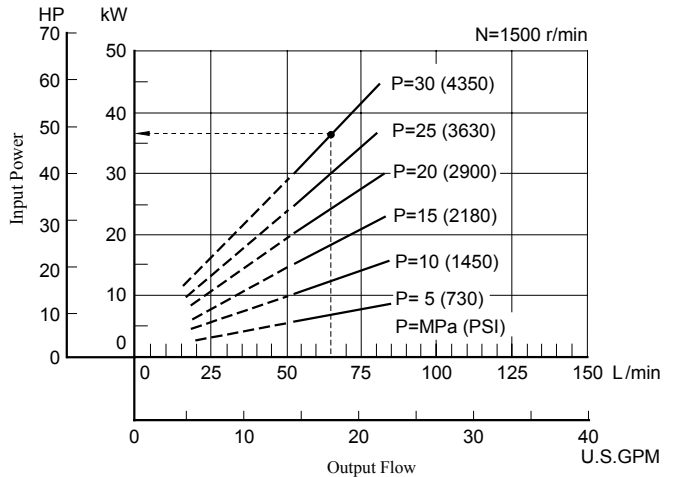

Note) The dotted line in the graph indicates less than minimum adjustable flow.

Typical Pump Characteristics

Typical Performance Characteristics of Type "AH56" at Viscosity 32 mm²/s (150 SSU) [ISO VG32 Oils, 40°C (104°F)]

■ Noise Level

[One metre (3.3 ft.) horizontally away from pump head cover]

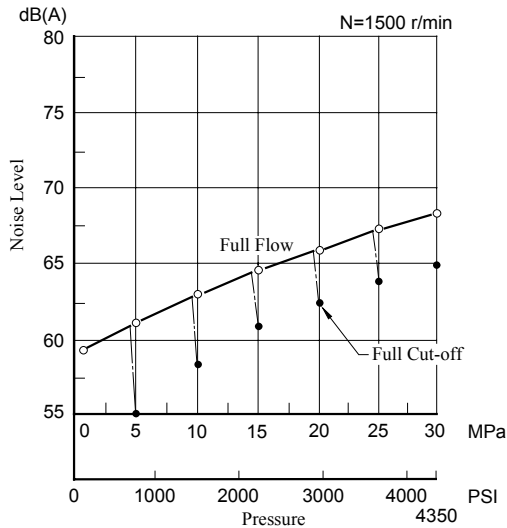

■ Full Cut-off Power

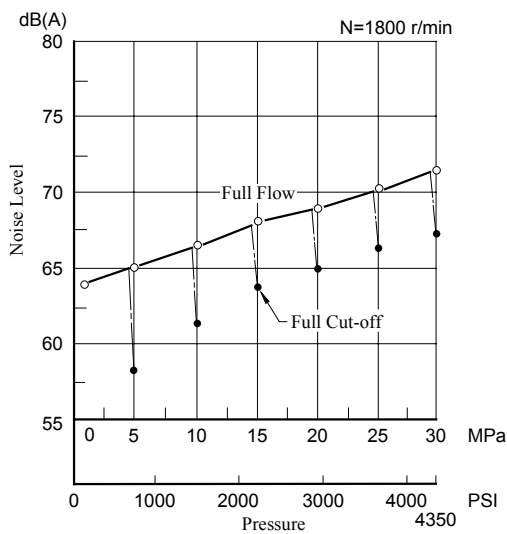
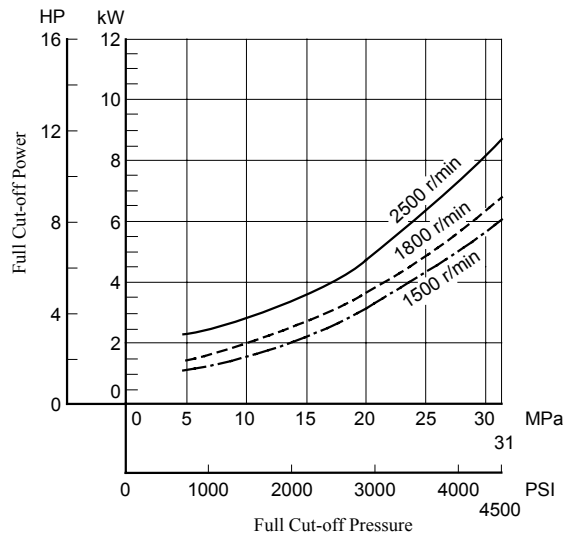

■ Drain

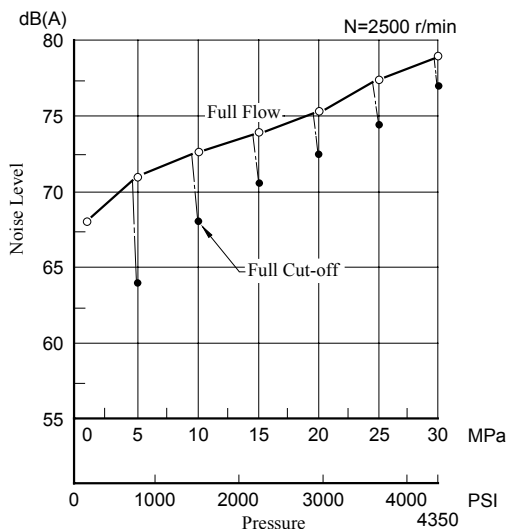
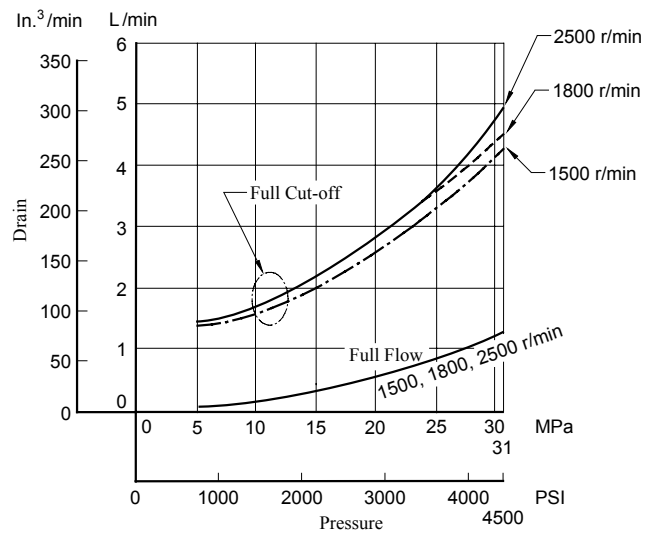

Flange Mtg.: AH16-FR01KK-10/1080/1090

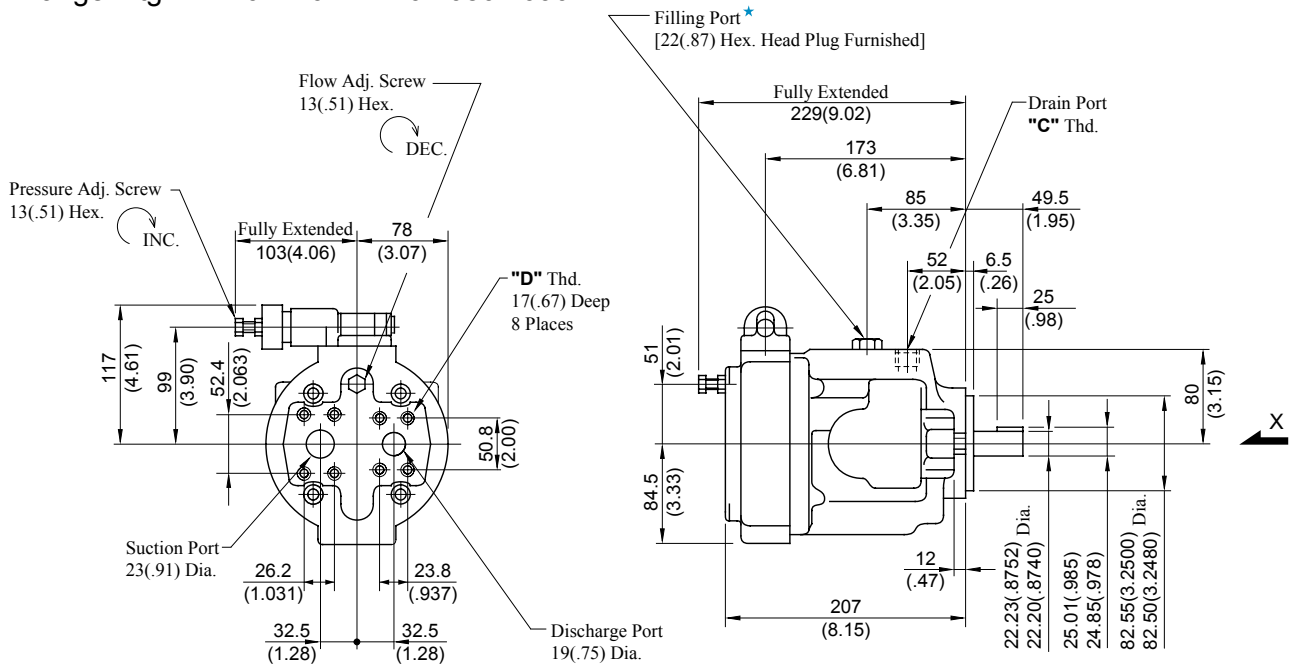

★ Install the pump so that the "Filling port" is at the top.

Model Numbers	"C" Thd.	"D" Thd.
AH16-FR01KK-10	Rc 1/2	M10
AH16-FR01KK-1080	1/2 BSP.F	
AH16-FR01KK-1090	1/2 NPT	3/8-16 UNC

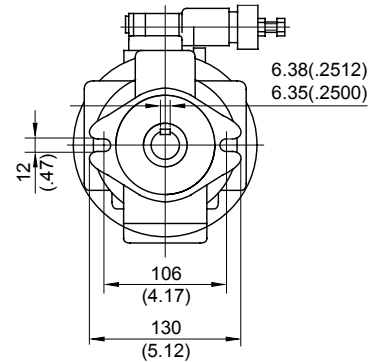

View Arrow X

DIMENSIONS IN
MILLIMETRES (INCHES)

Foot Mtg.: AH16-LR01KK-10/1080/1090

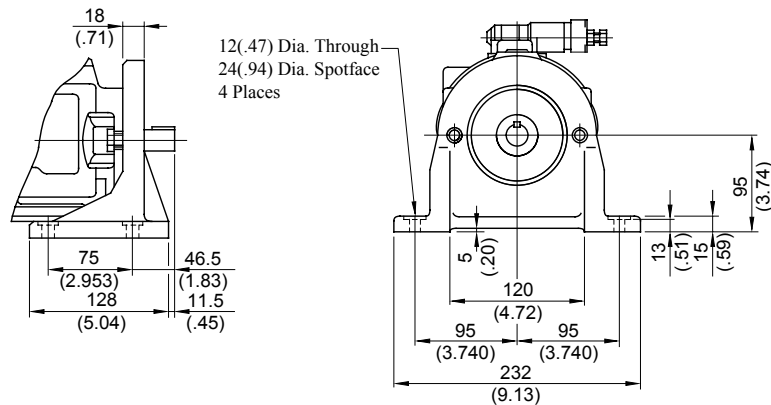

● For other dimensions, refer to "Flange Mtg.".

Installation Drawing

Flange Mtg.: AH37-FR01KK-20/2080/2090

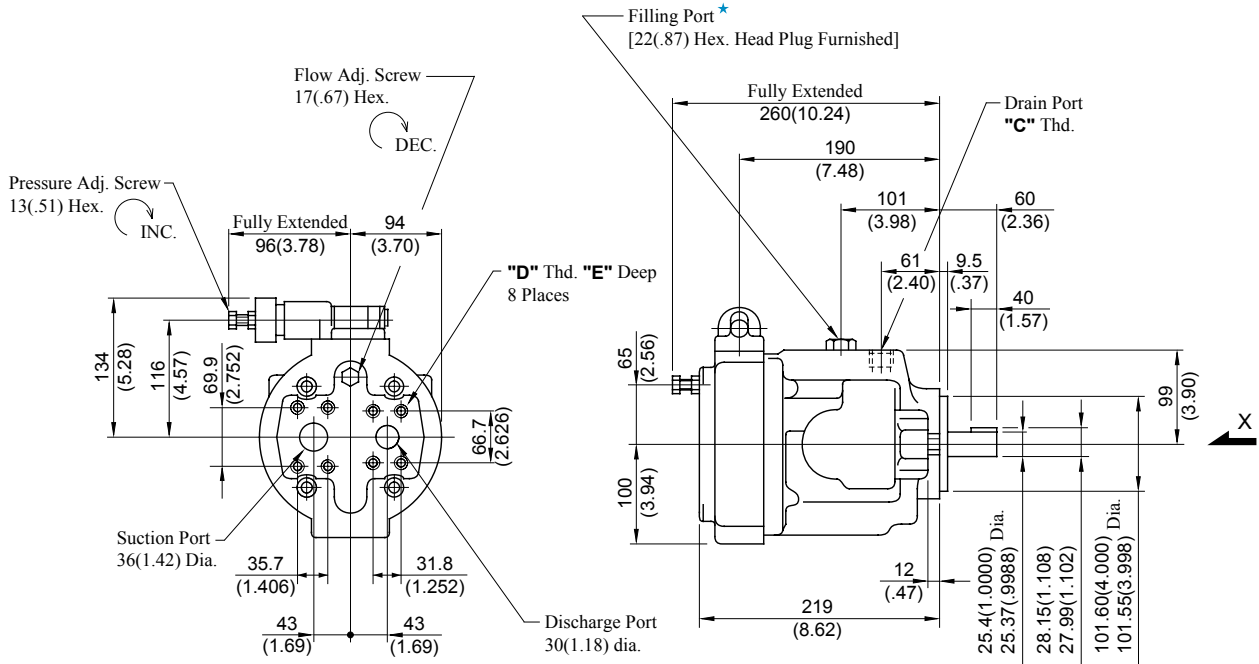

★ Install the pump so that the "Filling port" is at the top.

Model Numbers	"C" Thd.	"D" Thd.	E mm (IN.)
AH37-FR01KK-20	Rc 1/2	M12	19 (.75)
AH37-FR01KK-2080	1/2 BSP.F		
AH37-FR01KK-2090	1/2 NPT	1/2-13 UNC	21 (.83)

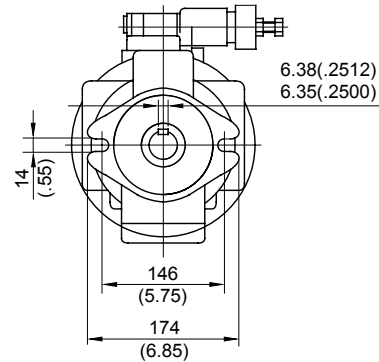

View Arrow X

DIMENSIONS IN
MILLIMETRES (INCHES)

Foot Mtg.: AH37-LR01KK-20/2080/2090

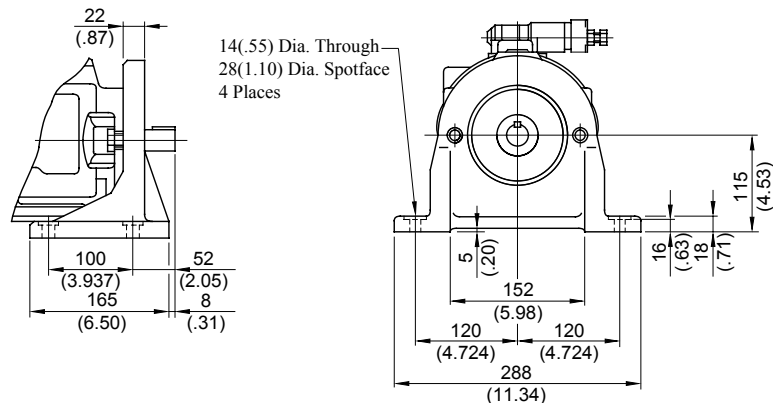

● For other dimensions, refer to "Flange Mtg.".

Flange Mtg.: AH56-FR01KK-11/1180/1190

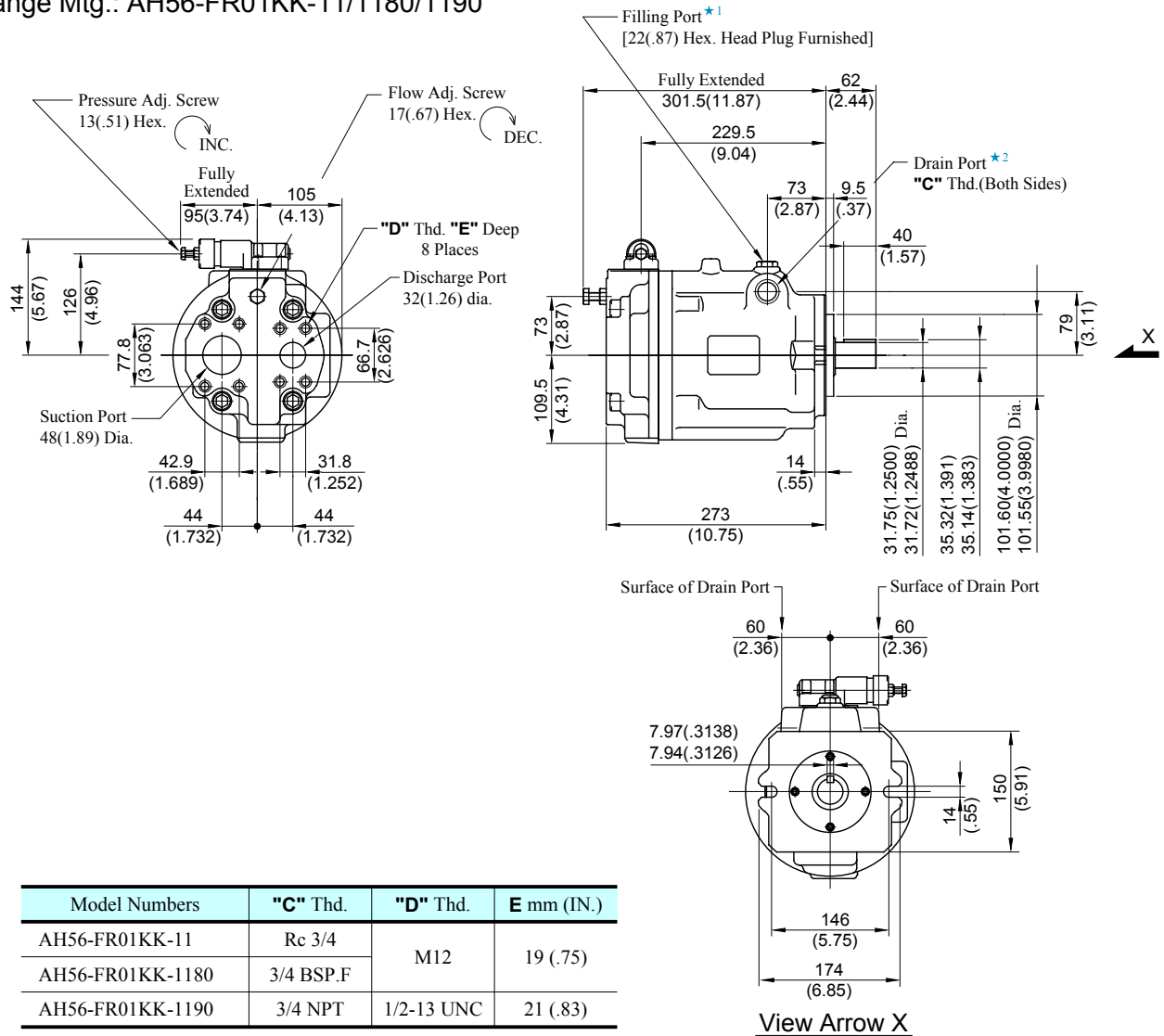

★1. Install the pump so that the "Filling Port" is at the top.

★2. Use either port of two drain ports at your option. Keep the remaining port plugged. Note that on the European design standard (1180 Design), only the left side, as viewed from the shaft end, of the drain port is machined.

DIMENSIONS IN
MILLIMETRES (INCHES)

Foot Mtg. : AH56-LR01KK-11/1180/1190

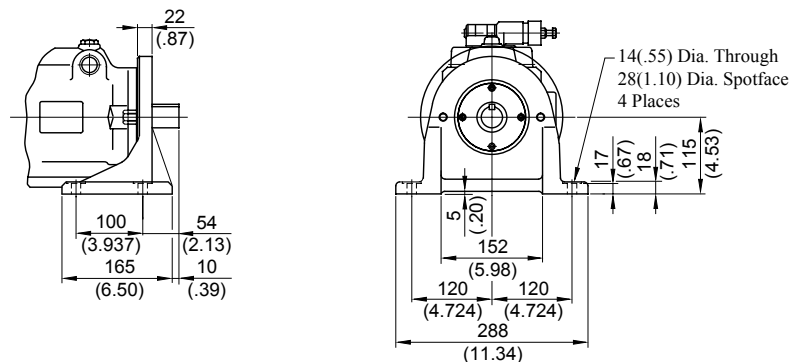

● For other dimensions, refer to "Flange Mfg."

Spare Parts List

AH16-*R01KK-10/1080/1090
AH37-*R01KK-20/2080/2090
AH56-*R01KK-11/1180/1190

CAUTION

When making replacement of seals, or bearings, please do it carefully after reading through the relevant instructions in the Operator's Manual.

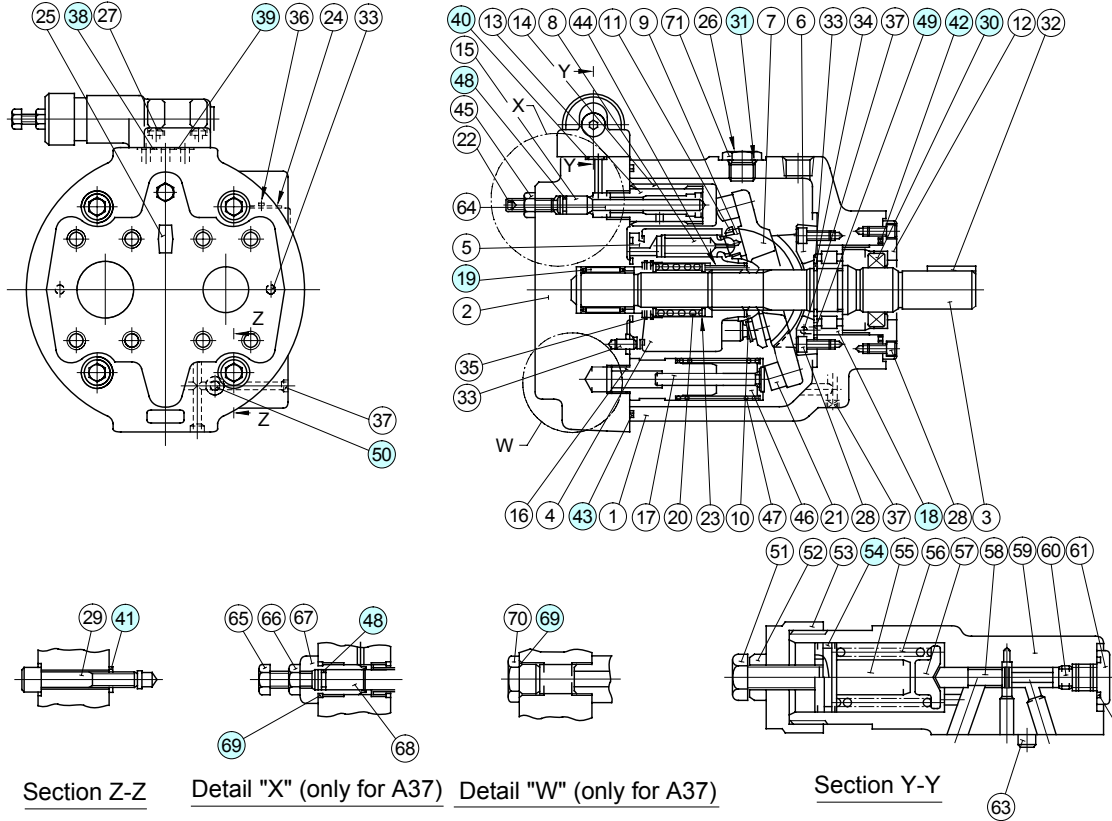

Section Z-Z

Detail "X" (only for A37)

Detail "W" (only for A37)

Section Y-Y

Item	Name of Parts	Parts Numbers			Qty.
		AH16	AH37	AH56	
18	Bearing	NUP 205E	NUP 206E	NUP 207E	1
19	Needle Bearing	HMK 2025V2	HMK 2530V2	HMK 3030V2	1
30*	Oil Seal	TCN 254511	TCN 355511	TCN 355511	1
31*	O-Ring		SO-NB-P14		1
38*	O-Ring		SO-NB-P9		1
39*	O-Ring	SO-NB-P11	SO-NB-P9	SO-NB-P9	1
40*	O-Ring		SO-NB-P9		1
41*	O-Ring	SO-NB-P12	SO-NB-P14	SO-NA-P20	4
42*	O-Ring	SO-NB-A139	SO-NB-G75	SO-NB-G75	1
43*	O-Ring	SO-NB-A162	SO-NB-A167	SO-NB-A170	1
48*	O-Ring		SO-NB-P8		1
49*	O-Ring	SO-NB-P6	SO-NB-P9	SO-NB-P9	1
50*	O-Ring		SO-NB-P9		1
54*	O-Ring		SO-NB-A018		1
62*	O-Ring		SO-NB-P10		1
69*	O-Ring	—	SO-NB-P18	—	2

* When ordering seals, please specify the seal kit number from the table below.

● List of Seal Kits

Pump Model Numbers	Seal Kit Numbers
AH16-*R01KK-10/1080/1090	KS-AH16-01-10
AH37-*R01KK-20/2080/2090	KS-AH37-01-20
AH56-*R01KK-11/1180/1190	KS-AH56-01-11